

Pull Up Station

FPW208



The vertical ladder can be used as a wall, to influence difficulty levels of various exercises such as hand stand push ups, Bulgarian split squats and push ups. Additionally the vertical ladder is perfect for stretching and offers a step up for reaching the pull up bar. The Pull Up Bar is made from solid steel and has a diameter of Ø32 mm. An ideal size to have a good grip.

Item no. FPW20800-0900	
General Product Information	
Dimensions LxWxH	273x11x240 cm
Age group	8+
Play capacity (users)	2
Color options	



Pull Up Station

FPW208



Post are made of $\text{Ø}101.6 \times 2\text{mm}$, pre-galvanized carbon steel and powder coated, a great protection to all conditions.



The connectors are made of die-cast aluminium, specially alloyed for the outdoor environments and heavy usage. The screws attaching the connectors are stainless steel and protected by zinc washers.



All bars intended for pull ups are made of solid, $\text{Ø}32\text{mm} \times 138\text{m}$, hot dip galvanised, S235JR steel bars. This diameter gives the right grip for everyone.

Item no. FPW20800-0900

Installation Information

Max. fall height	233 cm
Safety surfacing area	25.0 m ²
Total installation time	3.0
Excavation volume	0.53 m ³
Concrete volume	0.28 m ³
Footing depth (standard)	90 cm
Shipment weight	115 kg
Anchoring options	



Sustainability Data

FPW208



Cradle to Gate A1-A3	Total CO ₂ emission	CO ₂ e/kg	Recycled materials
	kg CO ₂ e	kg CO ₂ e/kg	%
FPW20800-0900	245.40	3.52	48.00

The overall framework applied for these factors is the Environmental Product Declaration (EPD), which quantifies "environmental information on the life cycle of a product and enable comparisons between products fulfilling the same function" (ISO, 2006). This follows the structure and applies a Life-Cycle Assessment approach to the entire Product stage from raw material through manufacturing (A1-A3))

Kompan A/S
 C.F. Tietgens Boulevard 32C
 DK-5220 Odense SØ
 Denmark



Verification of CO₂ calculation of: Fitness



Data version no. 2023-10-05

The CO₂ calculation and data are in compliance with the principles of a carbon footprint impact according to the GHG protocol (Greenhouse Gas Protocol), Scope 3, cradle to gate related to all individual components in the product category: "Fitness" represented by item no.: FAZ10100-0900.

(Scope 3 emissions include emission sources in the upstream and downstream value chain).

Date: 30. October 2023 | Valid until: 30. October 2025

Verified by:

Julie Marie Vejsgaard Larsen, LCA & EPD Consultant

Verification based on report: Validation of CO₂ calculation of 9 categories of Kompan product line, version 1.0, prepared by: Bureau Veritas HSE, Denmark: Julie M. V. Larsen.

Publication date: 30. October 2023

By Bureau Veritas HSE
 www.bureauveritas.dk
 +45 7731 1000



Pull Up Station

FPW208

* Max fall height | ** Total height | *** Safety surfacing area

* Max fall height | ** Total height

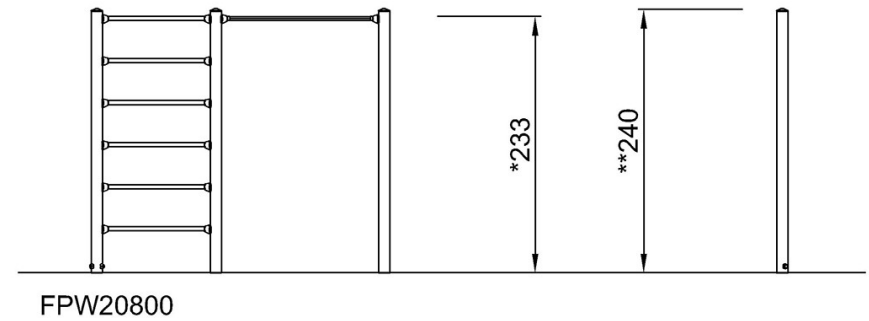
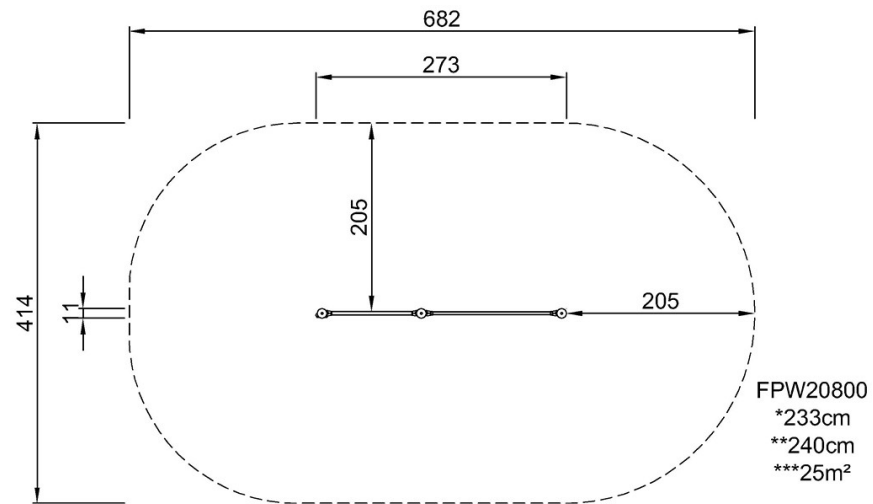

[Click to see TOP VIEW](#)

[Click to see SIDE VIEW](#)