

Turbo Challenge

NRO884

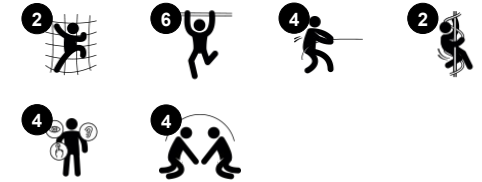

Item no. NRO884-1021	
General Product Information	
Dimensions LxWxH	266x150x263 cm
Age group	6+
Play capacity (users)	4
Color options	



The Turbo challenge is a play attraction that will make children come back again and again. With its responsive turning rings, there is no end to the fun of the Turbo Challenge. The side bars offer a nice entry point and a place to take a break and watch your friends. Children cooperate and turn-take while spinning, hanging by their legs or arms. This trains the

upper body muscles as well as spatial awareness, important for confidently navigating your body in the world. The upper body muscles and cores of children are constantly at work when playing in the Turbo Challenge.

Turbo Challenge

NRO884



Turbo challenge

Physical: upper body muscles are trained when hanging. Agility, proprioception and coordination are trained when spinning from one ring to the next. Spatial awareness and sense of balance are trained by the rotating motion. **Social-Emotional:** the sections of each of the spinners allow for more children hanging in arms or knees, cooperating. This trains empathy and turn-taking skills.



Side ladder

Physical: cross coordination and eye-hand coordination are supported when climbing the side ladder. The climbing also develops leg and arm muscles. **Social-Emotional:** social interaction when hanging out together, learning about turn taking and cooperation.

Turbo Challenge

NRO884



Coloured steel components have a base of hot dip galvanisation and a powder coated top finish. This provides an ultimate corrosion resistance in all climates around the world.



All Organic Robinia products by KOMPAN are made of Robinia wood from sustainable European sources. On request it can be supplied as FSC® Certified (FSC® C004450).



The paint used for coloured components is water based environmentally friendly with excellent UV resistance. The paint is in compliance with EN 71 Part 3.

Item no. NRO884-1021

Installation Information

Max. fall height	201 cm
Safety surfacing area	23.7 m ²
Total installation time	8.9
Excavation volume	0.50 m ³
Concrete volume	0.35 m ³
Footing depth (standard)	100 cm
Shipment weight	446 kg
Anchoring options	In-ground ✓



The Robinia wood can be supplied as untreated raw wood, painted with a brown coloured transparent pigment that maintains the golden wood colour or in a coloured version where selected components are painted in different colours.



Sustainability Data

NRO884



Cradle to Gate A1-A3	Total CO ₂ emission	CO ₂ e/kg	Recycled materials
	kg CO ₂ e	kg CO ₂ e/kg	%
NRO884-1021	131.92	0.37	4.26

The overall framework applied for these factors is the Environmental Product Declaration (EPD), which quantifies "environmental information on the life cycle of a product and enable comparisons between products fulfilling the same function" (ISO, 2006). This follows the structure and applies a Life-Cycle Assessment approach to the entire Product stage from raw material through manufacturing (A1-A3))

Kompan A/S
 C.F. Tietgens Boulevard 32C
 DK-5220 Odense SØ
 Denmark



Verification of CO₂ calculation of: Nature play



Data version no. 2023-10-05

The CO₂ calculation and data are in compliance with the principles of a carbon footprint impact according to the GHG protocol (Greenhouse Gas Protocol), Scope 3, cradle to gate related to all individual components in the product category: "Nature play" represented by item no.: NRO409-0621.

(Scope 3 emissions include emission sources in the upstream and downstream value chain).

Date: 30. October 2023 | Valid until: 30. October 2025

Verified by:

Julie Marie Vejsgaard Larsen, LCA & EPD Consultant

Verification based on report: Validation of CO₂ calculation of 9 categories of Kompan product line, version 1.0, prepared by: Bureau Veritas HSE, Denmark: Julie M. V. Larsen.

Publication date: 30. October 2023

By Bureau Veritas HSE
 www.bureauveritas.dk
 +45 7731 1000



Turbo Challenge

NRO884

* Max fall height | ** Total height | *** Safety surfacing area

* Max fall height | ** Total height

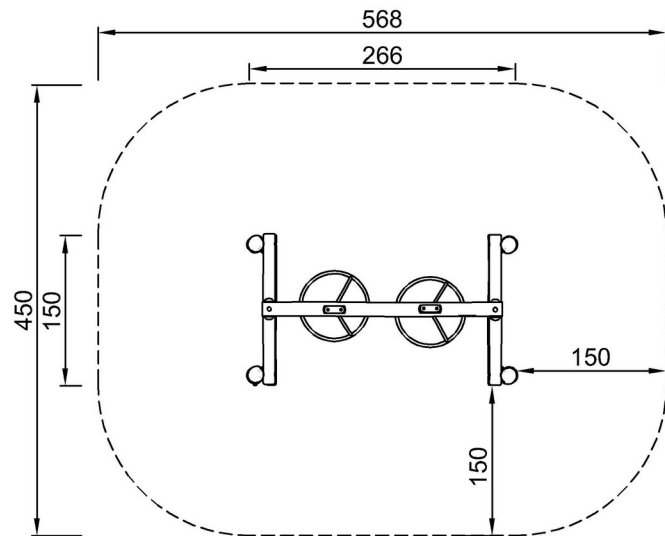

NRO884
*201cm
**263cm
***23.7m²

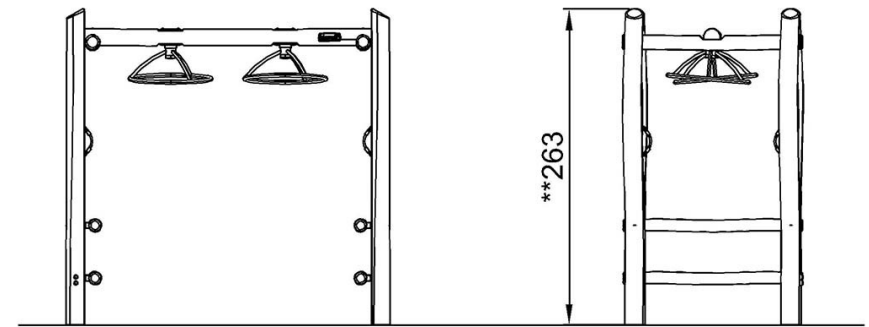

NRO884

[Click to see TOP VIEW](#)

[Click to see SIDE VIEW](#)