

# Waterlilies Balance Post

NRO822



Item no. NRO822-0601

## General Product Information

Dimensions LxWxH	1'5"x1'7"x1'1"
Age group	2 - 12
Play capacity (users)	1
Color options	 



The Waterlilies Balance Post adds a nice gathering point to the play area. With its floral shape, the Waterlilies Balance Post can accommodate play items that children bring to the playground. Toddlers often bring their favorite toys to the playground, and the possibility of storing them is always welcome. The Waterlilies Balance Post functions very

well as a spot for creative experiments, for instance building with sand. Last but not least, the Waterlilies Balance Post can also function as a balancing post or a seat.



# Waterlilies Balance Post

NRO822



## Balance posts

**Physical:** sense of balance is trained, and bone density built when jumping between and off the pods. **Social-Emotional:** turn-taking and cooperation as well as room for a seated rest with friends.



# Waterlilies Balance Post

NRO822



The steps are made of 21.5mm thick plywood made from alder and pine wood. Both sides are covered by 2 layers of phenolic film with anti slip net pattern. All cutting edges are sealed with paint to ensure long lifetime.

All Organic Robinia products by KOMPAN are made of Robinia wood from sustainable European sources. On request it can be supplied as FSC® Certified (FSC® C004450).

Item no. NRO822-0601	
Installation Information	
Max. fall height	1'1"
Safety surfacing area	143ft <sup>2</sup>
Total installation time	1.2
Excavation volume	0.05yd <sup>3</sup>
Concrete volume	0.03yd <sup>3</sup>
Footing depth (standard)	2'0"
Shipment weight	42lbs
Anchoring options	In-ground ✓
Warranty Information	
Plywood	5 Years
Robinia Wood	10 Years
Spare Parts Availability	10 Years

Elevated activities <b>0</b>	Accessible elevated activities	Accessible ground level activities	Accessible ground level play types
Present	<b>0</b>	<b>0</b>	<b>0</b>
Required	<b>0</b>	<b>0</b>	<b>0</b>

# Sustainability Data

NRO822



Cradle to Gate A1-A3	Total CO <sub>2</sub> emission	CO <sub>2</sub> e/kg	Recycled materials
	kg CO <sub>2</sub> e	kg CO <sub>2</sub> e/kg	%
<b>NRO822-0601</b>	2.54	0.16	0.45

The overall framework applied for these factors is the Environmental Product Declaration (EPD), which quantifies "environmental information on the life cycle of a product and enable comparisons between products fulfilling the same function" (ISO, 2006). This follows the structure and applies a Life-Cycle Assessment approach to the entire Product stage from raw material through manufacturing (A1-A3))

**Kompan A/S**  
 C.F. Tietgens Boulevard 32C  
 DK-5220 Odense SØ  
 Denmark



## Verification of CO<sub>2</sub> calculation of: Nature play



Data version no. 2023-10-05

The CO<sub>2</sub> calculation and data are in compliance with the principles of a carbon footprint impact according to the GHG protocol (Greenhouse Gas Protocol), Scope 3, cradle to gate related to all individual components in the product category: "Nature play" represented by item no.: NRO409-0621.

(Scope 3 emissions include emission sources in the upstream and downstream value chain).

**Date: 30. October 2023 | Valid until: 30. October 2025**

Verified by:

Julie Marie Vejsgaard Larsen, LCA & EPD Consultant

Verification based on report: Validation of CO<sub>2</sub> calculation of 9 categories of Kompan product line, version 1.0, prepared by: Bureau Veritas HSE, Denmark: Julie M. V. Larsen.

**Publication date: 30. October 2023**

By Bureau Veritas HSE  
 www.bureauveritas.dk  
 +45 7731 1000



# Waterlilies Balance Post

NRO822

\* Max fall height | \*\* Total height | \*\*\* Safety surfacing area

\* Max fall height | \*\* Total height

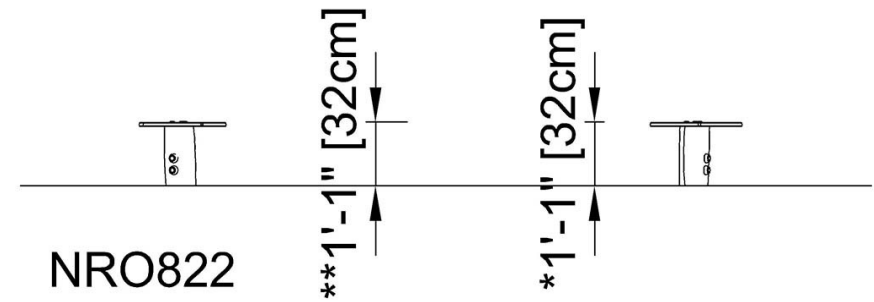
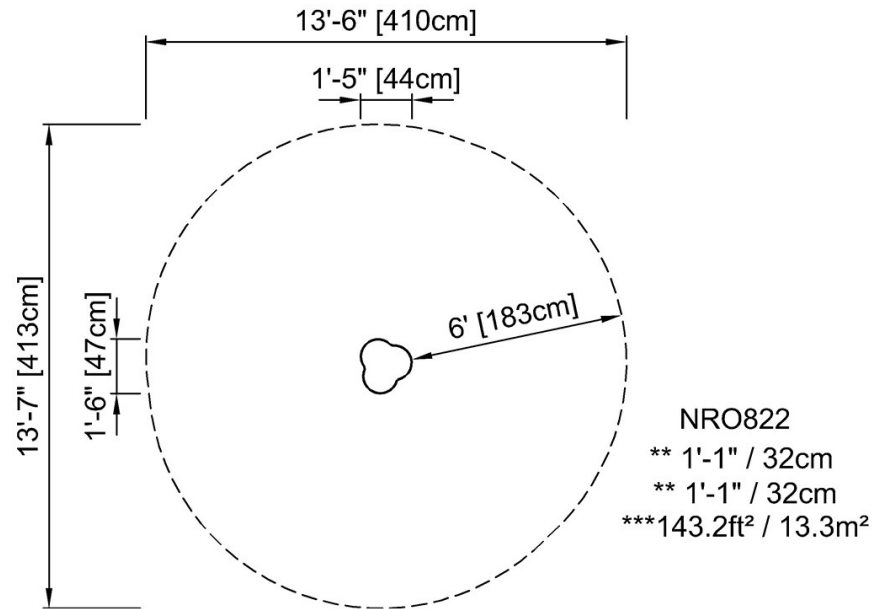

[Click to see TOP VIEW](#)

[Click to see SIDE VIEW](#)