

# Byhus med butik

PCM52321

**KOMPANI**  
Let's play



Varenr. PCM52321-0901	
<b>Generel produktinformation</b>	
Dimensioner LxBxH	502x290x363 cm
Alder	2+
Antal brugere	19
Farvemuligheder	●

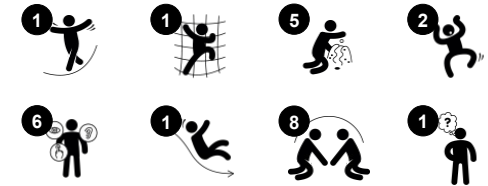

The countless play activities of the Town House with Cafe inspire children to play, move and imagine together, for long, again and again. The socialise-and explore play features on ground level, with table and bench as well as a wealth of tactile moving play details, offer countless dramatic play scenarios. The play features connect children in play under, around

and on the play unit. The elevated level of the platform gives a good view from above and the high slide is an attractive and stomach tickling experience. Sliding additionally trains the children's spatial awareness, their sense of balance and their core stability. These are important fundamentals in movement confidence. Thus, the Town House with cafe offers

physical, social-emotional and cognitive-creative play benefits in one wildly attractive play unit that children will want to visit again and again.

# Byhus med butik

PCM52321



## Balkon

**Social-emotionelle evner:** balkonen understøtter interaktion og kommunikation mellem børn og voksne.



## Tema

**Kognitive evner:** er tematisk og understøtter rolleleg, som stimulerer sprog- og kommunikationsevner.



## Bænk

**Social-emotionelle evner:** opfordrer til socialt samvær og samarbejde. Man kan også tage et hvil.



## Ovn og komfur

**Social-emotionelle evner:** invites cooperation and communication due to the two-sidedness. **Kognitive evner:** stimulates language and communication skills with its tangible theme. **Kreative evner:** children can leave their mark, placing the oven knobs in different positions.



## Rutsjebane

**Fysiske evner:** her udvikles balance og rumlig bevidsthed, som børn rutsjer. Desuden styrkes muskler, når børn sidder op og rutsjer. **Social-emotionelle evner:** stimulerer empati ved skiftevis turtagning



## Kaffemaskine

**Social-emotionelle evner:** trains cooperation and turn-taking as children put materials into the coffee funnel. **Kognitive evner:** passing materials through the funnel and sieve supports children's logical thinking skills. Toddlers train their object permanence understanding: that materials can still exist when out of sight. Themes support dramatic play, which is known to stimulate language skills.



## Stige

**Fysiske evner:** her understøttes krydskoordination og hånd-øje-koordination når børn klatrer på stigen. Her bruger de især ben- og armmuskulatur. **Social-emotionelle evner:** her lærer børn at skiftes og samarbejde.

# Byhus med butik

PCM52321

**KOMPAN**  
Let's play



Paneler af 19 mm EcoCore™. EcoCore™ er et meget holdbart materiale, som ikke kun kan genbruges efter brug, men som også består af materiale, der er produceret af +95 % genanvendt materiale fra fødevareemballageaffald.



Main posts with hot dip galvanized steel footing are available in different materials: Pre-galvanized inside and outside with powder coated top finish steel posts. Lead free aluminum with color anodized top finish. TexMade posts of 95% post-consumer recycled PE and textile waste.



Alle platforme er understøttet af unikt designede aluminiumsprofiler med lavt kulstofindhold og flere fastgørelsesmuligheder. De grå støbte platforme er lavet af 75 % PP-materiale, af genbrugsmaterialer, med et skridsikkert mønster og en struktureret overflade.

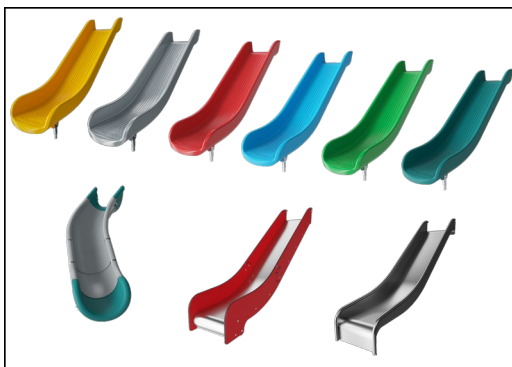

Rutsjebanerne kan vælges i seks forskellige farver og materialer. Lige eller buede PE-rutsjebaner, støbt i ét stykke, er fremstillet af 33 % genanvendt forbrugeraffald, som fødevareemballage, i forskellige farver. Kombinerede EcoCore™-sider og rustfrit stål. Rustfrit stål designet i ét stykke for mere hærværkssikret løsninger.



KOMPAN GreenLine-versioner er designet med ultimative holdbare materialer med den lavest mulige CO2e-udledningsfaktor. TexMade-stolpe, EcoCore™-paneler af 95 % genanvendt forbrugsaffald og støbte PP-platforme.

Varenr. PCM52321-0901

## Installationsinformation

Maks. faldhøjde	148 cm
Faldområde	33,7 m <sup>2</sup>
Installationstid (timer)	23,2
Udgravningsmængde	0,40 m <sup>3</sup>
Betonmængde	0,00 m <sup>3</sup>
Forankringsdybde	90 cm
Fragtvægt	820 kg
Forankringsmuligheder	Overflade ✓ I jorden ✓

## Garanti

EcoCore HDPE	Livstid
Udhulede PE-dele	10 år
Stolpe	10 år
PP-dæk	10 år
Garanterede reservedele	10 år

# Bæredygtighedsdata

PCM52321



Vugge-til-port A1-A3	Total CO <sub>2</sub> udledning	CO <sub>2</sub> e/kg	Gen-anvendte materialer
	kg CO <sub>2</sub> e	kg CO <sub>2</sub> e/kg	%
PCM52321-0901	866,08	1,50	74,37

Den overordnede ramme for disse faktorer er Environmental Product Declaration (EPD), som kvantificerer "miljøoplysninger om et produkts livscyklus og muliggør sammenligninger mellem produkter, der opfylder samme funktion" (ISO, 2006). Dette følger strukturen og anvender en livscyklusvurderingstilgang til hele produktfasen fra råvarer til fremstilling (A1-A3))

## Kompan A/S

C.F. Tietgens Boulevard 32C  
DK-5220 Odense SØ  
Denmark



## Verification of CO<sub>2</sub> calculation of: Play systems



Data version no. 2023-10-05

The CO<sub>2</sub> calculation and data are in compliance with the principles of a carbon footprint impact according to the GHG protocol (Greenhouse Gas Protocol), Scope 3, cradle to gate related to all individual components in the product category: "Play systems" represented by item no.: PCM200321-0950.

(Scope 3 emissions include emission sources in the upstream and downstream value chain).

**Date: 30. October 2023 | Valid until: 30. October 2025**

Verified by:



Julie Marie Vejsgaard Larsen, LCA & EPD Consultant

Verification based on report: Validation of CO<sub>2</sub> calculation of 9 categories of Kompan product line, version 1.0, prepared by: Bureau Veritas HSE, Denmark: Julie M. V. Larsen.

**Publication date: 30. October 2023**

By Bureau Veritas HSE  
www.bureauveritas.dk  
+45 7731 1000



# Byhus med butik

PCM52321

\* Maks. faldhøjde | \*\* Samlet højde | \*\*\* Faldområde

\* Maks. faldhøjde | \*\* Samlet højde

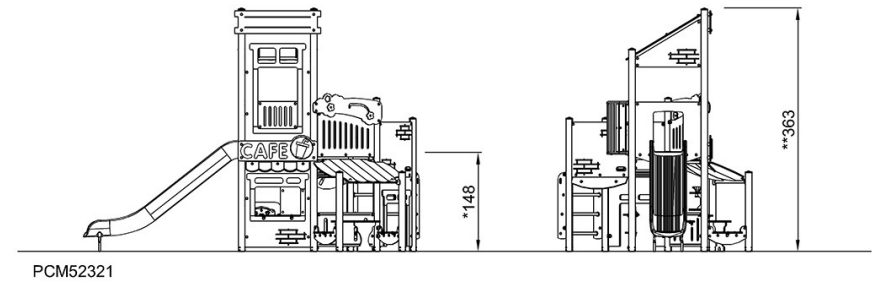
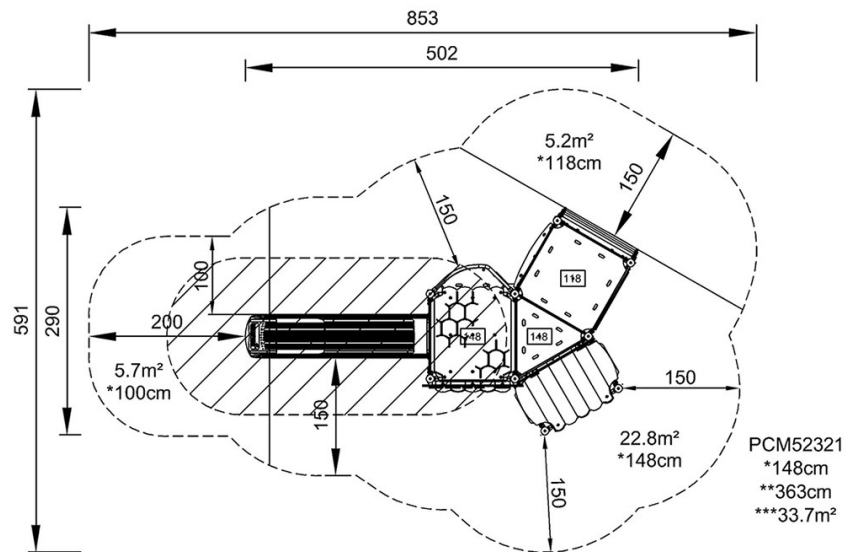

[Klik for at se FRA OVEN](#)

[Klik for at se FRA SIDEN](#)