

# Elements Cliff Rider

PCE112421

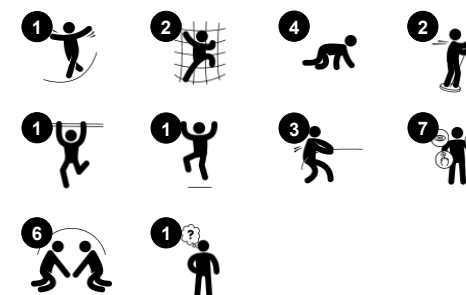

Item no. PCE112421-0901	
General Product Information	
Dimensions LxWxH	140x502x443 cm
Age group	6+
Play capacity (users)	12
Colour options	



The amazing taller Cliff Rider is hugely attractive to school age children. It calls for repeated loops of action, again and again. The intensely thrilling ride high up in the air, on a small footrest, is for the courageous. And those who aren't at the first go, get there with a little help from their friends. Till then, there is ample climbing and gliding on the climbing walls,

climbing cleats on poles and the fireman's pole. The Cliff Rider trains muscle force, tension, timing and sequencing of movements. Judging your body's movements, object control as well as timing is quite a complex task, but a necessary life skill that makes it possible to navigate the body securely and confidently through environments, e.g. street traffic.

Furthermore, the self-confidence that children gain from overcoming their initial hesitations to travel on the Cliff Rider, is the more reason that they should.

# Elements Cliff Rider

PCE112421



## Wall climber

**Physical:** climbing supports cross coordination, proprioception, and the development of major muscle groups and hand strength. **Social-Emotional:** two-sided climbing spurs social interaction and turn-taking.



## Fireman's pole

**Physical:** supports coordination, arm and core muscles. Landing strengthens bone density. **Social-Emotional:** turn-taking and risk-taking.



## Supportive handholds

**Physical:** handhold provides good grip for less confident climbers. Trains upper body muscles. **Social-Emotional:** allows for a range of physical abilities to enter independently and securely, play for all.



## Cliff rider

**Physical:** pushing with the feet and pushing and pulling with the arms train major muscles. Timing, force and sequence of movements train proprioception and coordination skills. **Social-Emotional:** cooperating with others and turn-taking skills are supported on the Cliff Rider. Helping others overcome their hesitation trains empathy and consideration. **Cognitive:** the force and coordination of movements add to childrens' confidence and teach them important life skills.

# Elements Cliff Rider

PCE112421



The pole vaulter pole is made of a welded steel construction with a 360° standing platform of Ekogrip. The double sided curved handles are made of EcoCore material. The pole combines superior ergonomics with outstanding functionality.



The rocking movement back and forth is controlled by a heavy duty scaled double rubber torsion spring element. The rubber element ensures a safe movement and reduces speed towards the tower platforms. The base cover of molded PE material with high impact resistance.



The curved start platforms are made of a curved stainless steel plate with non skid texture. The lower part of the platform is supported by a EcoCore board for safe foothold and the rubber bumper is placed to receive the pole.

Item no. PCE112421-0901	
Installation Information	
Max. fall height	260 cm
Safety surfacing area	41.1 m <sup>2</sup>
Total installation time	20.9
Excavation volume	0.70 m <sup>3</sup>
Concrete volume	0.32 m <sup>3</sup>
Footing depth (standard)	90 cm
Shipment weight	687 kg
Anchoring options	Surface ✓ In-ground ✓
Warranty Information	
EcoCore HDPE	Lifetime
Galvanised Steel	Lifetime
Post	10 years
PP Decks	10 years
Spare Parts Guarantee	10 years



The climbing elements displayed are moulded in one piece with a minimum 5mm wall thickness. The climbing elements are made of recyclable PE, which has a high impact resistance across a wide temperature span which ensures vandal resistance.



The main posts are made of high quality pre-galvanized steel with powder coated top finish. Post tops are closed with caps of UV stabilized nylon (PA6). The grey colored molded decks are made of 75% post-consumer ocean waste PP material with a non-skid pattern and textured surface. All decks are supported by uniquely designed, low-carbon aluminum profiles with multiple attachment options.

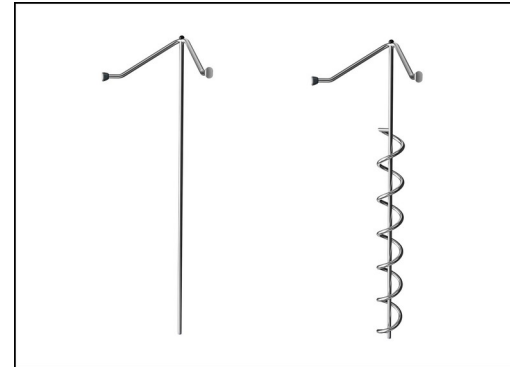

Activities are made of high-quality stainless steel which is cleaned by a total pickling process after manufacturing to ensure a smooth and clean gliding surface.



# Sustainability Data

PCE112421



Cradle to Gate A1-A3	Total CO <sub>2</sub> emission	CO <sub>2</sub> e/kg	Recycled materials
	kg CO <sub>2</sub> e	kg CO <sub>2</sub> e/kg	%
PCE112421-0901	1,532.32	2.87	50.36

The overall framework applied for these factors is the Environmental Product Declaration (EPD), which quantifies "environmental information on the life cycle of a product and enable comparisons between products fulfilling the same function" (ISO, 2006). This follows the structure and applies a Life-Cycle Assessment approach to the entire Product stage from raw material through manufacturing (A1-A3))

**Kompan A/S**  
C.F. Tietgens Boulevard 32C  
DK-5220 Odense SØ  
Denmark



## Verification of CO<sub>2</sub> calculation of: Play systems



Data version no. 2023-10-05

The CO<sub>2</sub> calculation and data are in compliance with the principles of a carbon footprint impact according to the GHG protocol (Greenhouse Gas Protocol), Scope 3, cradle to gate related to all individual components in the product category: "Play systems" represented by item no.: PCM200321-0950.

(Scope 3 emissions include emission sources in the upstream and downstream value chain).

**Date: 30. October 2023 | Valid until: 30. October 2025**

Verified by:

Julie Marie Vejsgaard Larsen, LCA & EPD Consultant

Verification based on report: Validation of CO<sub>2</sub> calculation of 9 categories of Kompan product line, version 1.0, prepared by: Bureau Veritas HSE, Denmark: Julie M. V. Larsen.

**Publication date: 30. October 2023**

By Bureau Veritas HSE  
www.bureauveritas.dk  
+45 7731 1000



# Elements Cliff Rider

PCE112421

\* Max fall height | \*\* Total height | \*\*\* Safety surfacing area

\* Max fall height | \*\* Total height

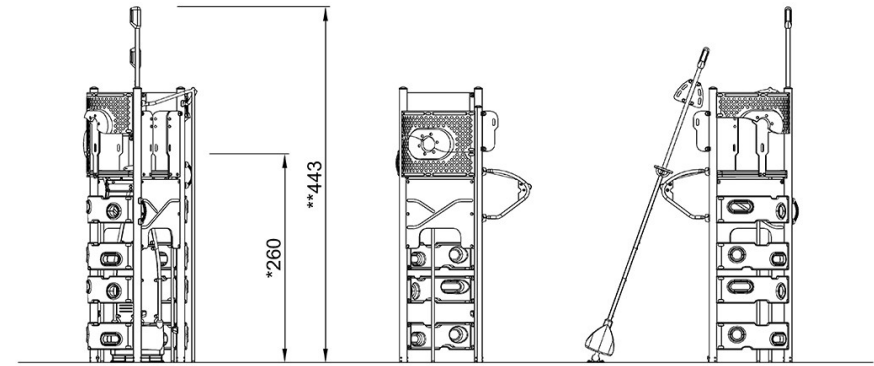
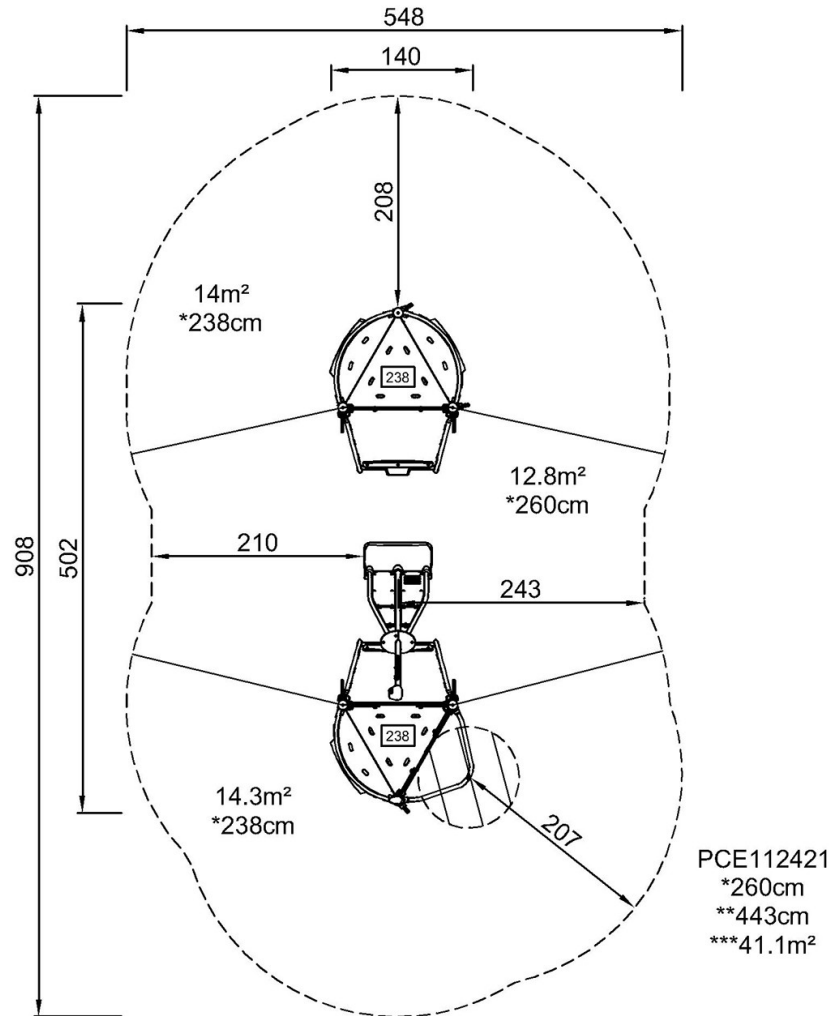

PCE112421

[Click to see TOP VIEW](#)

[Click to see SIDE VIEW](#)