

# Liberty Play Hammock

PCX801



Item no. PCX801-0902

## General Product Information

|                       |   |
|-----------------------|---|
| Dimensions LxWxH      | 3'11"x3'11"x3'3"  |
| Age group             | 2 - 12  |
| Play capacity (users) | 1   |
| Color options         |    |



The Liberty Play Hammock is a perfect and easily accessed spot for a moment of relaxation. It offers the opportunity for swaying gently, seated or lying, welcoming all ages and abilities. Even though sized for one user, children often find ways to use it together. The play hammock is a great meeting point that invites children to hang out and interact with

each other. Social skills, such as children's abilities to share, listen and learn about the world around them are supported. Apart from supporting children's social skills, the play hammock stimulates children's balance when swaying gently. This is an important skill in relation to children's ability to pay attention and concentrate.

# Liberty Play Hammock

PCX801



## Hammock

**Physical:** coordination and sense of balance when swaying. **Social-Emotional:** meeting, pushing friends gently back and forth, turn-taking. **Cognitive:** for toddlers cause and effect understanding.



# Liberty Play Hammock

PCX801



All steel components are made of high quality materials. The posts have an alloy with improved tensile and yield strength according to the NYCP material specification. The painted aluminum post caps are riveted to the top of the post.



All panels and one-piece welded steel grids are made of low carbon steel and corrosion treated by hot dip galvanization or metallization with a minimum thickness according to NYCP material specification.

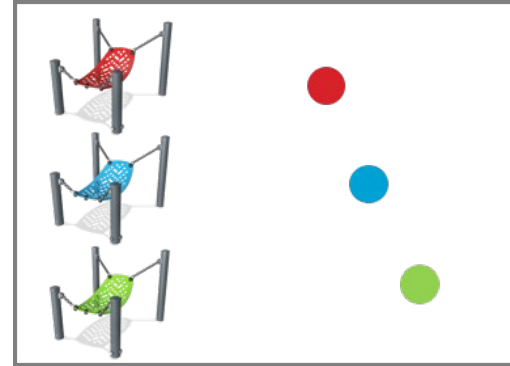

The products are designed in three different standard color combinations: Red and light blue, Light blue and lime green, Green and lime green. The layouts of the play structures can be customized through the KOMPAN Variant Team.

| Item no. PCX801-0902     |   |
|--------------------------|---|
| Installation Information |   |
| Max. fall height         | 1'4"  |
| Safety surfacing area    | 211ft <sup>2</sup>                            |
| Total installation time  | 3.2   |
| Excavation volume        | 0.14yd <sup>3</sup>                           |
| Concrete volume          | 0.07yd <sup>3</sup>                           |
| Footing depth (standard) | 2'9"  |
| Shipment weight          | 194lbs  |
| Anchoring options        | In-ground <input checked="" type="checkbox"/> |
| Warranty Information     |   |
| EcoCore HDPE             | Lifetime                                      |
| HDG post                 | Lifetime                                      |
| HPL decks                | 15 Years                                      |
| Ropes & nets             | 10 Years                                      |
| Spare Parts Availability | 10 Years                                      |

| Elevated activities 0 | Accessible elevated activities | Accessible ground level activities | Accessible ground level play types |
|-----------------------|--------------------------------|------------------------------------|------------------------------------|
| Present               | 0                              | 1                                  | 1                                  |
| Required              | 0                              | 1                                  | 1                                  |

**ASTM  
F1487**  
compliant

# Sustainability Data

PCX801



| Cradle to Gate A1-A3 | Total CO <sub>2</sub> emission | CO <sub>2</sub> e/kg    | Recycled materials |
|----------------------|--------------------------------|-------------------------|--------------------|
|                      | kg CO <sub>2</sub> e           | kg CO <sub>2</sub> e/kg | %                  |
| <b>PCX801-0902</b>   | 204.95                         | 2.92                    | 46.91              |

The overall framework applied for these factors is the Environmental Product Declaration (EPD), which quantifies "environmental information on the life cycle of a product and enable comparisons between products fulfilling the same function" (ISO, 2006). This follows the structure and applies a Life-Cycle Assessment approach to the entire Product stage from raw material through manufacturing (A1-A3))

**Kompan A/S**  
 C.F. Tietgens Boulevard 32C  
 DK-5220 Odense SØ  
 Denmark



## Verification of CO<sub>2</sub> calculation of: Play systems



Data version no. 2023-10-05

The CO<sub>2</sub> calculation and data are in compliance with the principles of a carbon footprint impact according to the GHG protocol (Greenhouse Gas Protocol), Scope 3, cradle to gate related to all individual components in the product category: "Play systems" represented by item no.: PCM200321-0950.

(Scope 3 emissions include emission sources in the upstream and downstream value chain).

**Date: 30. October 2023 | Valid until: 30. October 2025**

Verified by:

Julie Marie Vejsgaard Larsen, LCA & EPD Consultant

Verification based on report: Validation of CO<sub>2</sub> calculation of 9 categories of Kompan product line, version 1.0, prepared by: Bureau Veritas HSE, Denmark: Julie M. V. Larsen.

**Publication date: 30. October 2023**

By Bureau Veritas HSE  
 www.bureauveritas.dk  
 +45 7731 1000



# Liberty Play Hammock

PCX801

\* Max fall height | \*\* Total height | \*\*\* Safety surfacing area

\* Max fall height | \*\* Total height

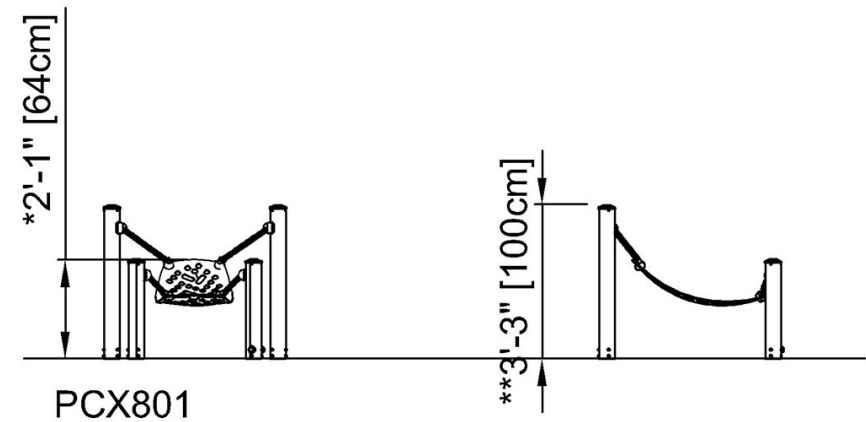
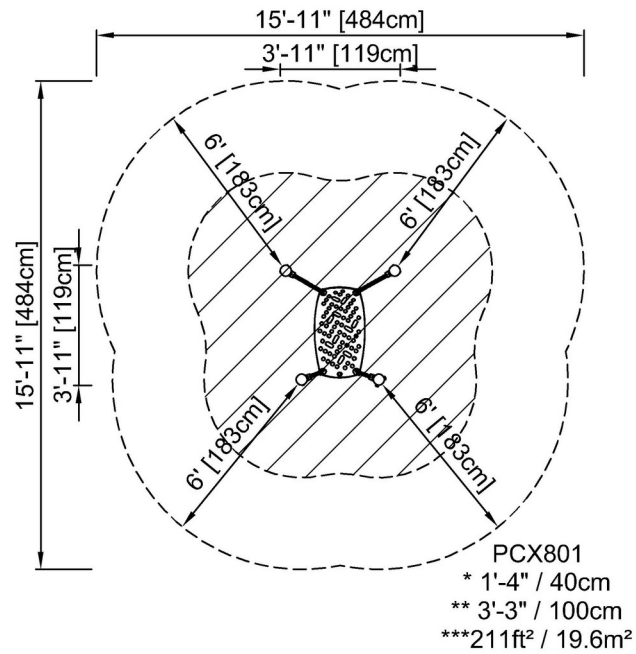

[Click to see TOP VIEW](#)

[Click to see SIDE VIEW](#)