

Tower with Slide

NRO1003

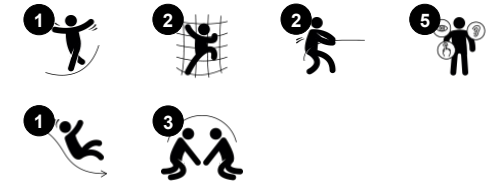

Item no. NRO1003-1001	
General Product Information	
Dimensions LxWxH	313x193x320 cm
Age group	3+
Play capacity (users)	6
Color options	



The Tower with Slide appeals immensely to children. With its climb and slide variation, children will try it out again, training cardio and muscles as they loop the slide and the varied climb access points. The inclined net is a fun challenge to climb, and it trains the child's proprioception: the awareness of where the body parts are in space and how much force

and distance it takes to move securely. The sturdy stair-step is a even more challenging with its chunky-grip, vertical steps. The platform offers a nice view. The slide is an all time favourite. When toddlers slide, they train their balance and spatial awareness. These motor skills are important for understanding your own body in space, and speed and distance. This is

an important skill for instance in managing street traffic securely.



Tower with Slide

NRO1003



Platform

Social-Emotional: Important life skills like courage, self-confidence, consideration and turn-taking are built.

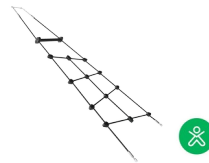

Climbing net

Physical: the inclined net supports the upward climbing movement of the body. The net supports cross-body coordination, which impacts coordination of the right and left part of brain, fundamental for other skills such as the ability to read. The asymmetry of the net challenges the children's climbing.



Slide

Physical: sliding develops spatial awareness and a sense of balance. Furthermore, the core muscles are trained when sitting upright going down. **Social-Emotional:** empathy stimulated by turn-taking. **Cognitive:** young children develop their understanding of space, speed and distances when sliding down quickly.

Tower with Slide

NRO1003



All Organic Robinia products by KOMPAN are made of Robinia wood from sustainable European sources. On request it can be supplied as FSC® Certified (FSC® C004450).



Ropes of UV-stabilized PES rope strands with inner steel cable reinforcement. The polyester yarn is made from +95% post-consumer materials and is inductively melted onto each strand.



The stainless-steel slides with one-piece slide bed are made of high-quality stainless-steel AISI 304.

Item no. NRO1003-1001

Installation Information

Max. fall height	100 cm
Safety surfacing area	21.1 m ²
Total installation time	7.2
Excavation volume	0.99 m ³
Concrete volume	0.08 m ³
Footing depth (standard)	100 cm
Shipment weight	402 kg
Anchoring options	In-ground ✓ Surface ✓



Slide interface panel of 19mm EcoCore™. EcoCore™ is a highly durable, eco-friendly material, which is not only recyclable after use, but is also made of +95% recycled post-consumer material from e.g., food packing waste in both core and colorful outer layer.



The Robinia wood can be supplied as untreated raw wood, painted with a brown coloured transparent pigment that maintains the golden wood colour or in a coloured version where selected components are painted in different colours.



Sustainability Data

NRO1003

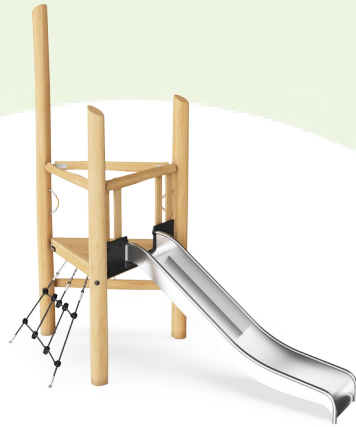

Cradle to Gate A1-A3	Total CO ₂ emission	CO ₂ e/kg	Recycled materials
	kg CO ₂ e	kg CO ₂ e/kg	%
NRO1003-1001	246.33	0.84	10.66

The overall framework applied for these factors is the Environmental Product Declaration (EPD), which quantifies "environmental information on the life cycle of a product and enable comparisons between products fulfilling the same function" (ISO, 2006). This follows the structure and applies a Life-Cycle Assessment approach to the entire Product stage from raw material through manufacturing (A1-A3))

Kompan A/S
 C.F. Tietgens Boulevard 32C
 DK-5220 Odense SØ
 Denmark



Verification of CO₂ calculation of: Nature play



Data version no. 2023-10-05

The CO₂ calculation and data are in compliance with the principles of a carbon footprint impact according to the GHG protocol (Greenhouse Gas Protocol), Scope 3, cradle to gate related to all individual components in the product category: "Nature play" represented by item no.: NRO409-0621.

(Scope 3 emissions include emission sources in the upstream and downstream value chain).

Date: 30. October 2023 | Valid until: 30. October 2025

Verified by:

Julie Marie Vejsgaard Larsen, LCA & EPD Consultant

Verification based on report: Validation of CO₂ calculation of 9 categories of Kompan product line, version 1.0, prepared by: Bureau Veritas HSE, Denmark: Julie M. V. Larsen.

Publication date: 30. October 2023

By Bureau Veritas HSE
 www.bureauveritas.dk
 +45 7731 1000



Tower with Slide

NRO1003

* Max fall height | ** Total height | *** Safety surfacing area

* Max fall height | ** Total height

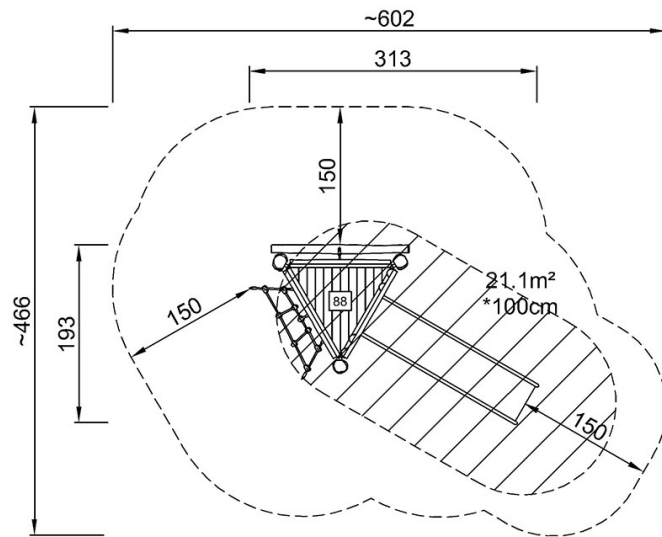

NRO1003-1001
*100cm
**320cm
***21.1m²

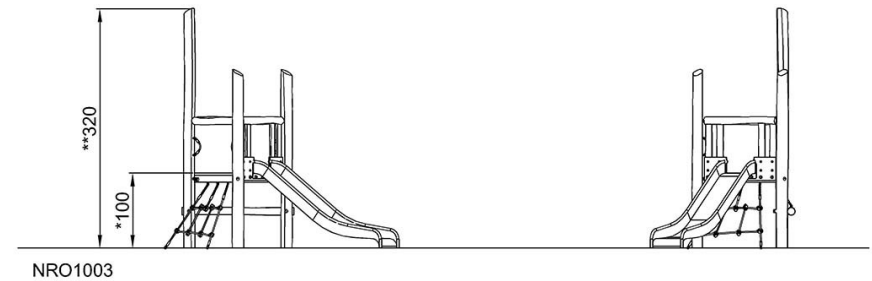

NRO1003

[Click to see TOP VIEW](#)

[Click to see SIDE VIEW](#)