

# Play Tower with Double Floor

PCM101221

**KOMPAN**  
Let's play



Item no. PCM101221-0603	
General Product Information	
Dimensions LxWxH	196x255x211 cm
Age group	1+
Play capacity (users)	8
Color options	

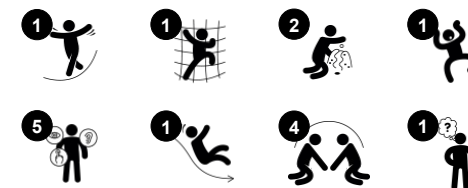

The Play Tower with double floor is great for toddlers. With its thrilling physical and social play stimuli, it attracts toddlers time and time again. The two floors and the balcony create a great, open sliding loop. The play panels and the balcony invite play from the outside in and vice versa. The ergonomic stairway accommodates play for a multitude of physical

abilities. The platform has multiple holding points: holes in floors, stairs and sides, to add grip assistance. The play panel flowers add attractive, tactile points for play and conversations. All in all, the activities invite physical play and social interaction, looping the stair and slide and interacting with the outside through balcony and window play panel.



Data is subject to change without prior notice.

# Play Tower with Double Floor

PCM101221

**KOMPANI**  
Let's play



## Balcony

**Social-Emotional:** the balcony invites meetings and interaction with people on ground level. **Cognitive:** invites dramatic play and performance, which stimulates language development.



## Flower panel

**Social-Emotional:** invites cooperation due to the two-sidedness and provides for parallel play. **Cognitive:** suggests a theme and supports dramatic play, which stimulates language and communication skills.



## Slide

**Physical:** sliding develops spatial awareness and a sense of balance. Furthermore, the core muscles are trained when sitting upright going down. **Social-Emotional:** empathy stimulated by turn-taking. **Cognitive:** young children develop their understanding of space, speed and distances when sliding down quickly.



## Window

**Social-Emotional:** invites interaction between sides and cooperative play.

# Play Tower with Double Floor

PCM101221



Panels of 19mm EcoCore™. EcoCore™ is a highly durable, eco friendly material, which is not only recyclable after use, but is also produced from +95% recycled post consumer material from food packing waste. Wooden panels of impregnated and brown painted pine wood with vertical steel profiles.



Main posts with hot dip galvanized steel footing are available in different materials: Pressure impregnated pine wood posts. Pre-galvanized inside and outside with powder coated top finish steel posts. Lead free aluminum with color anodized top finish. Greenline TexMade posts of 95% post-consumer recycled PE and textile waste.

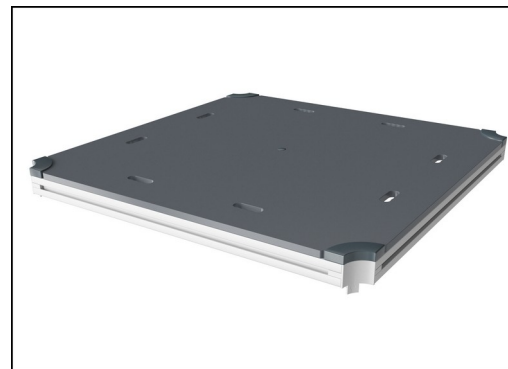

All decks are supported by unique designed low-carbon aluminum profiles with multiple attachment options. The grey colored molded decks are made of 75% post-consumer waste PP material with a non-skid pattern and texture surface.

Item no. PCM101221-0603	
Installation Information	
Max. fall height	100 cm
Safety surfacing area	18.6 m <sup>2</sup>
Total installation time	10.2
Excavation volume	0.36 m <sup>3</sup>
Concrete volume	0.00 m <sup>3</sup>
Footing depth (standard)	60 cm
Shipment weight	304 kg
Anchoring options	In-ground ✓ Surface ✓



Roof is made from rotomoulded PE with 33% Post-consumer materials. PE has high impact resistance across a wide temperature span which ensures durability.

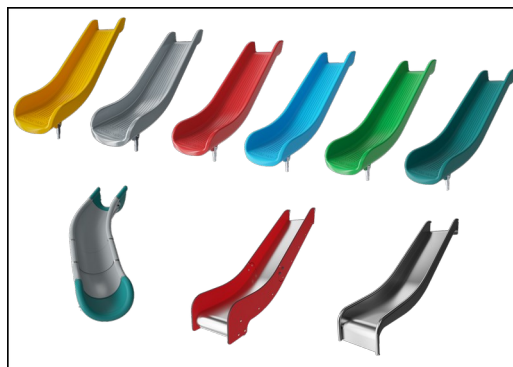

The slides can be chosen in six different colors and three materials: Straight or curved one-piece molded PE slides, made from 33% recycled post-consumer materials in different colours. Combined EcoCore™ sides and stainless-steel. Full stainless steel in one piece design for more vandalism proof solutions.



KOMPAN GreenLine versions are designed with ultimate environmentally friendly materials with lowest possible CO2e emission factor. TexMade post, EcoCore™ panels of 95% post-consumer recycled waste and molded PP decks.



# Sustainability Data

PCM101221



Cradle to Gate A1-A3	Total CO <sub>2</sub> emission	CO <sub>2</sub> e/kg	Recycled materials
	kg CO <sub>2</sub> e	kg CO <sub>2</sub> e/kg	%
<b>PCM101221-0651</b>	341.47	1.60	66.62
<b>PCM101221-0603</b>	327.30	1.54	24.01

The overall framework applied for these factors is the Environmental Product Declaration (EPD), which quantifies "environmental information on the life cycle of a product and enable comparisons between products fulfilling the same function" (ISO, 2006). This follows the structure and applies a Life-Cycle Assessment approach to the entire Product stage from raw material through manufacturing (A1-A3))

**Kompan A/S**  
C.F. Tietgens Boulevard 32C  
DK-5220 Odense SØ  
Denmark



## Verification of CO<sub>2</sub> calculation of: Play systems



Data version no. 2023-10-05

The CO<sub>2</sub> calculation and data are in compliance with the principles of a carbon footprint impact according to the GHG protocol (Greenhouse Gas Protocol), Scope 3, cradle to gate related to all individual components in the product category: "Play systems" represented by item no.: PCM200321-0950.

(Scope 3 emissions include emission sources in the upstream and downstream value chain).

**Date: 30. October 2023 | Valid until: 30. October 2025**

Verified by:

Julie Marie Vejsgaard Larsen, LCA & EPD Consultant

Verification based on report: Validation of CO<sub>2</sub> calculation of 9 categories of Kompan product line, version 1.0, prepared by: Bureau Veritas HSE, Denmark: Julie M. V. Larsen.

**Publication date: 30. October 2023**

By Bureau Veritas HSE  
www.bureauveritas.dk  
+45 7731 1000



# Play Tower with Double Floor

PCM101221

\* Max fall height | \*\* Total height | \*\*\* Safety surfacing area

\* Max fall height | \*\* Total height

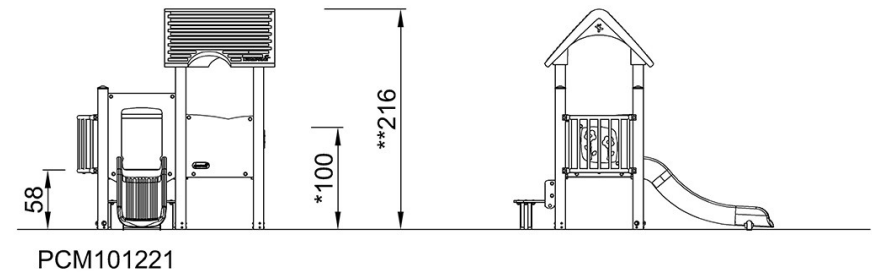
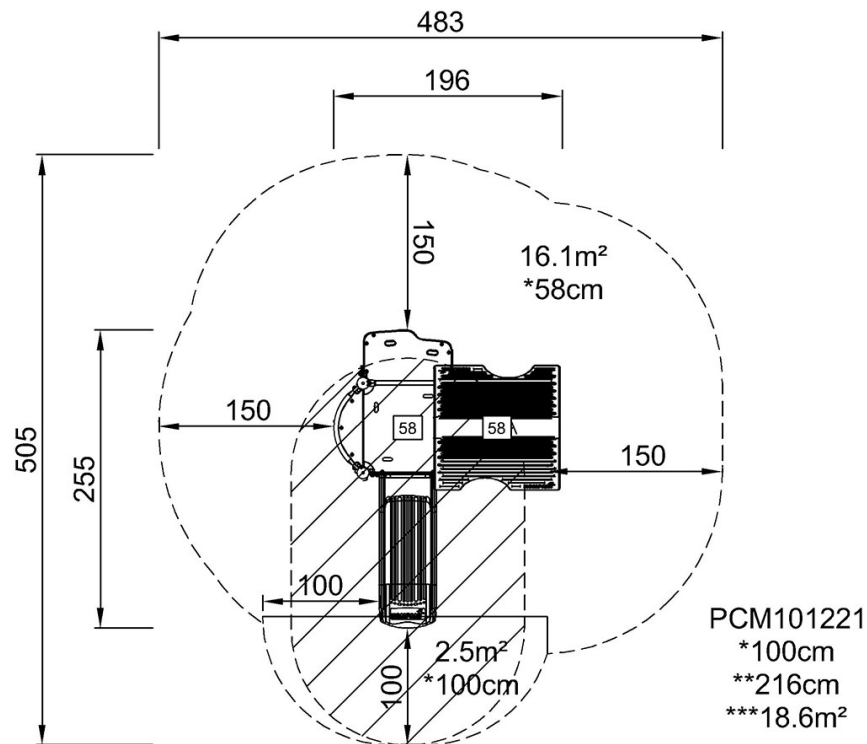

[Click to see TOP VIEW](#)

[Click to see SIDE VIEW](#)