



Item no. PCE205321-0903	
General Product Information	
Dimensions LxWxH	605x333x418 cm
Age group	2+
Play capacity (users)	19
Colour options	● ● ●



The Gogetter is a fantastic structure with loads of play opportunities that will encourage children to stay and play, and return again and again. These play experiences will support children's development in all areas. The slide supports physical skills such as balance and spatial awareness. The climbing net supports strength and cross-coordination, important

skills for physical as well as intellectual development. There is more than one way to climb, which supports play for children who seek variety and challenge. With so many play activities, social experiences are also supported, especially with such features as the flower panel, where children can play and cooperate. The flower panel adds a tactile

feature that stimulates cause-and-effect understanding. The Gogetter is perfect for active and fun play.

Gogetter

PCE205321



Slide

Physical: develops spatial awareness, sense of balance and trains core muscles when sitting upright going down. **Social-Emotional:** empathy stimulated by turn-taking. **Cognitive:** young children develop their understanding of space, speed and distances when sliding down.



Faces panel

Social-Emotional: spurs group play and conversations with its two-sidedness. **Cognitive:** stimulates theory of mind and the understanding of facial expressions as symbols for emotions. **Creative:** the pointer can be placed in different directions to create stories or change main point of attraction.



Binoculars

Cognitive: the binoculars promote dramatic play, a great trainer of language and communication skills. **Creative:** the binoculars can be moved around. Looking through them gives a new perspective on the world.



Pipe ladder

Physical: cross coordination and eye-hand coordination are supported when children climb the ladder. The climbing also supports leg and arm muscles. **Social-Emotional:** learning about turn taking and cooperation.



Flower panel

Social-Emotional: invites cooperation due to the two-sides and provides for parallel play. **Cognitive:** stimulates cause and effect and logical thinking: sounds are made when the flower moves through the grooves **Creative:** children can leave their mark, placing the flowers in different positions.



Fireman's pole

Physical: supports coordination, arm and core muscles. Landing strengthens bone density. **Social-Emotional:** turn-taking and risk-taking. **Cognitive:** young children develop their understanding of space, speed and distances when gliding down fast.

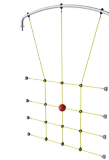

Climbing net

Physical: children's cross-body coordination and muscle strength is developed by climbing and crawling through, training proprioception and spatial awareness. **Social-Emotional:** the big meshes allow for more children being seated together, sharing.

Gogetter

PCE205321

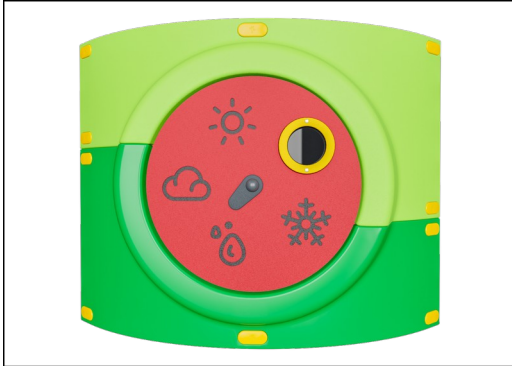

The Curved ELEMENTS panels are moulded of UV stabilised recyclable PE with multiple options for in-built play features that also ensures a strong panel solution. Straight panels are made of KOMPAN 19mm PE EcoCore™ which is a highly durable, eco-friendly and recyclable material.

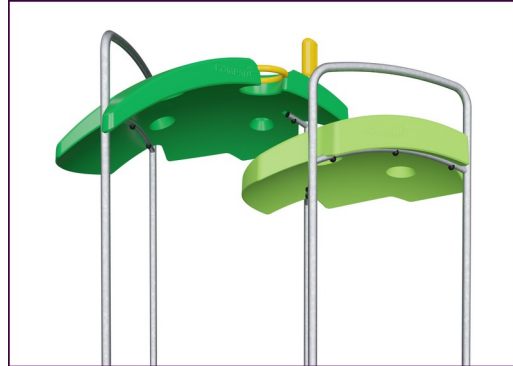

The ELEMENTS roofs are made of recyclable PE with a minimum wall thickness of 5 mm to ensure high durability in all climates around the world. The steel pipes are hot-dip galvanised inside and outside for maximum durability.



ELEMENTS products are available in three different colour combinations: 1. classic blue, green 2. blossom, orange, yellow 3. nature lime, green

Item no. PCE205321-0903

Installation Information

Max. fall height	176 cm
Safety surfacing area	38.8 m ²
Total installation time	19.5
Excavation volume	1.11 m ³
Concrete volume	0.29 m ³
Footing depth (standard)	90 cm
Shipment weight	656 kg
Anchoring options	Surface ✓ In-ground ✓

Warranty Information

EcoCore HDPE	Lifetime
Post	10 years
PP Decks	10 years
Ropes & Nets	10 years
Spare Parts Guarantee	10 years



The main posts are made of high quality pre-galvanized steel with powder coated top finish. Post tops are closed with caps of UV stabilized nylon (PA6). The grey colored molded decks are made of 75% post-consumer ocean waste PP material with a non-skid pattern and textured surface. All decks are supported by uniquely designed, low-carbon aluminum profiles with multiple attachment options.

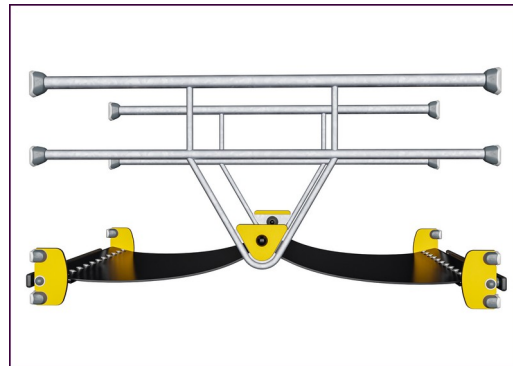

ELEMENTS rubber membranes are conveyor belt made of layers of rubber mixed of natural rubber and SBR rubber and embedded with layers of armouring made of woven PE and PA. The thickness 8mm ensures high durability in any environment.

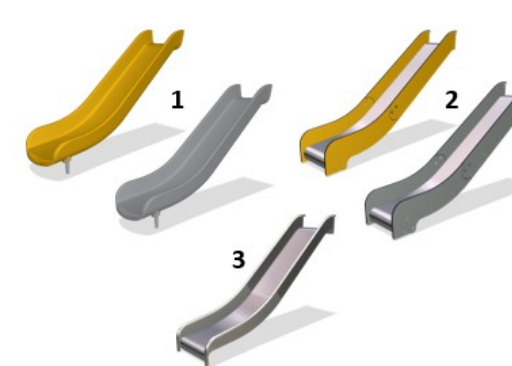

The slides are available in either moulded PE in different colours or in full stainless steel - AISI304 t= 2mm.



Sustainability Data

PCE205321



Cradle to Gate A1-A3	Total CO ₂ emission	CO ₂ e/kg	Recycled materials
	kg CO ₂ e	kg CO ₂ e/kg	%
PCE205321-0903	1,151.18	2.33	54.85

The overall framework applied for these factors is the Environmental Product Declaration (EPD), which quantifies "environmental information on the life cycle of a product and enable comparisons between products fulfilling the same function" (ISO, 2006). This follows the structure and applies a Life-Cycle Assessment approach to the entire Product stage from raw material through manufacturing (A1-A3))

Kompan A/S
 C.F. Tietgens Boulevard 32C
 DK-5220 Odense SØ
 Denmark



Verification of CO₂ calculation of: Play systems



Data version no. 2023-10-05

The CO₂ calculation and data are in compliance with the principles of a carbon footprint impact according to the GHG protocol (Greenhouse Gas Protocol), Scope 3, cradle to gate related to all individual components in the product category: "Play systems" represented by item no.: PCM200321-0950.

(Scope 3 emissions include emission sources in the upstream and downstream value chain).

Date: 30. October 2023 | Valid until: 30. October 2025

Verified by:

Julie Marie Vejsgaard Larsen, LCA & EPD Consultant

Verification based on report: Validation of CO₂ calculation of 9 categories of Kompan product line, version 1.0, prepared by: Bureau Veritas HSE, Denmark: Julie M. V. Larsen.

Publication date: 30. October 2023

By Bureau Veritas HSE
 www.bureauveritas.dk
 +45 7731 1000



* Max fall height | ** Total height | *** Safety surfacing area

* Max fall height | ** Total height

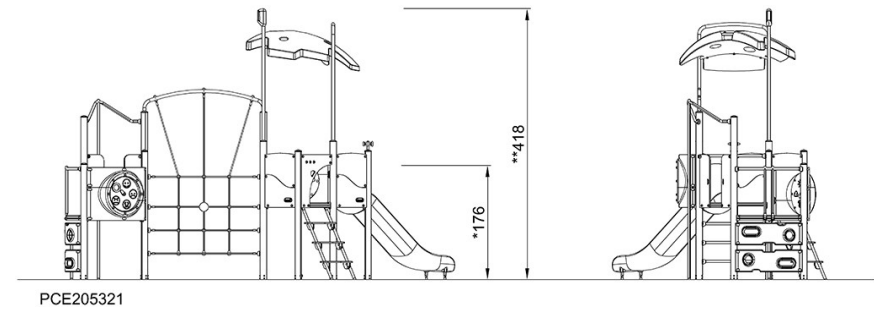
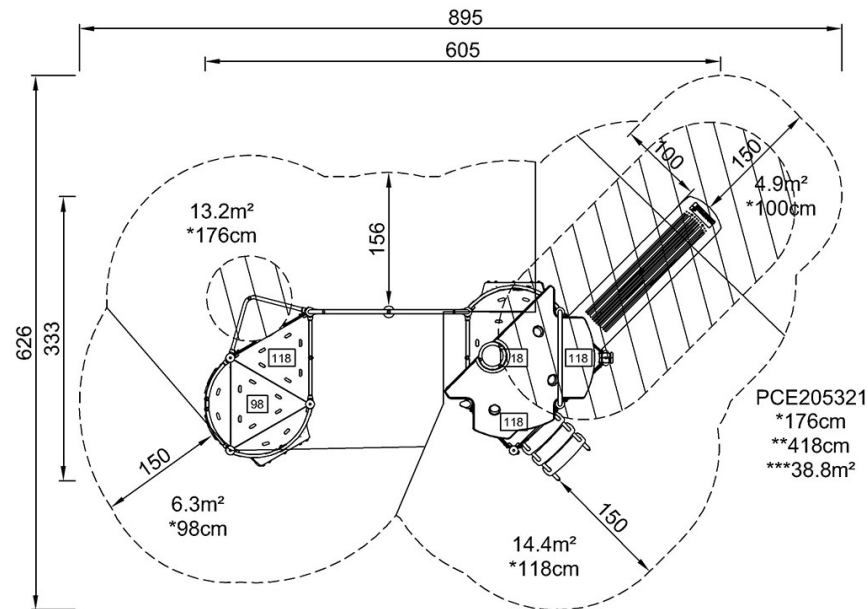

[Click to see TOP VIEW](#)

[Click to see SIDE VIEW](#)