

Magnetic Bells Pro

FAZ102

KOMPAN
Let's play



Item no. FAZ10200-0900	
General Product Information	
Dimensions LxWxH	390x106x334 cm
Age group	13+
Play capacity (users)	3
Colour options	

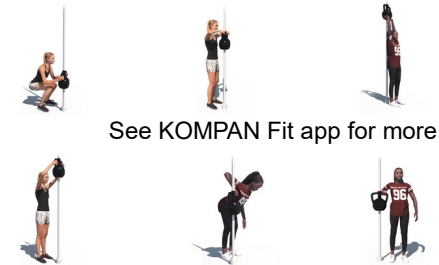

An innovative magnetic breaking system allows the user to increase the resistance by increasing the speed of movement. The patented system also functions as brake when someone drops the magnetic bells and will reduce the impact significantly. The option to choose between a light, medium or heavy training weight offers a scalable training and it

makes the Magnetic Bells an accessible piece of equipment for both the trained and the untrained. The Magnetic bells move freely up and down and can spin 360°. This allows the users to do exercises which are very similar to medicine balls and kettle bell exercises. The Magnetic bell comes with 3 different weights 6, 9 and 12kg.



Magnetic Bells Pro

FAZ102



The uniquely designed Magnetic Bells are made of PUR and a reinforced aluminium steel frame that ensures a strong design. The ergonomically shaped handles guarantee a good and pleasant grip for all users.



The big instruction signs are made of a 8mm polycarbonate sheets with clear instructions printed directly on the panels. The polycarbonate is extremely strong and provides a vandalism proof construction.

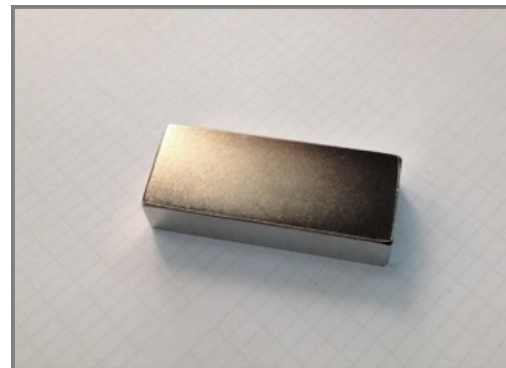

The magnets which are used are High Strength Neodymium magnets. The magnetic radiation is under strict control, the radiation level never exceeds 5 Gauss (0.5mT), which makes them perfectly safe to use as an training item.

Item no. FAZ10200-0900	
Installation Information	
Max. fall height	0 cm
Safety surfacing area	14.2 m ²
Total installation time	7.1
Excavation volume	0.79 m ³
Concrete volume	0.40 m ³
Footing depth (standard)	90 cm
Shipment weight	404 kg
Anchoring options	In-ground ✓ Surface ✓
Warranty Information	
Coated steel parts	10 years
PUR components	10 years
Signs	10 years
Spare parts guaranteed	10 years



The tubes on which the magnetic bells move are ø40mm, made of grade AW 6082-T6 aluminium and have an anodized layer of 20µm. The tube has a full steel core for structural integrity.



To ensure the integrity of the main frame, the orange coloured main posts are made of ø101.6 x 3mm steel posts, which are hot dip galvanised and powder coated Orange (RAL2010). The supportive posts receive the same surface treatment and are made of ø76.1 x 3.6mm steel tubes, powder coated grey (RAL7012).



All KOMPAN fitness products are compliant with the ASTM F3101 & EN16630 Outdoor Fitness Standards. Load tests are performed as a static test by adding dynamic factors as well as safety factors to the specified load of 78kg per user. A product intended for 1 user is loaded with 420kg.



Sustainability Data

FAZ102



Cradle to Gate A1-A3	Total CO ₂ emission	CO ₂ e/kg	Recycled materials
	kg CO ₂ e	kg CO ₂ e/kg	%
FAZ10200-0900	1,040.81	3.33	42.24

The overall framework applied for these factors is the Environmental Product Declaration (EPD), which quantifies "environmental information on the life cycle of a product and enable comparisons between products fulfilling the same function" (ISO, 2006). This follows the structure and applies a Life-Cycle Assessment approach to the entire Product stage from raw material through manufacturing (A1-A3))

Kompan A/S
 C.F. Tietgens Boulevard 32C
 DK-5220 Odense SØ
 Denmark



Verification of CO₂ calculation of: Fitness



Data version no. 2023-10-05

The CO₂ calculation and data are in compliance with the principles of a carbon footprint impact according to the GHG protocol (Greenhouse Gas Protocol), Scope 3, cradle to gate related to all individual components in the product category: "Fitness" represented by item no.: FAZ10100-0900.

(Scope 3 emissions include emission sources in the upstream and downstream value chain).

Date: 30. October 2023 | Valid until: 30. October 2025

Verified by:

Julie Marie Vejsgaard Larsen, LCA & EPD Consultant

Verification based on report: Validation of CO₂ calculation of 9 categories of Kompan product line, version 1.0, prepared by: Bureau Veritas HSE, Denmark: Julie M. V. Larsen.

Publication date: 30. October 2023

By Bureau Veritas HSE
 www.bureauveritas.dk
 +45 7731 1000



Magnetic Bells Pro

FAZ102

* Max fall height | ** Total height | *** Safety surfacing area

* Max fall height | ** Total height

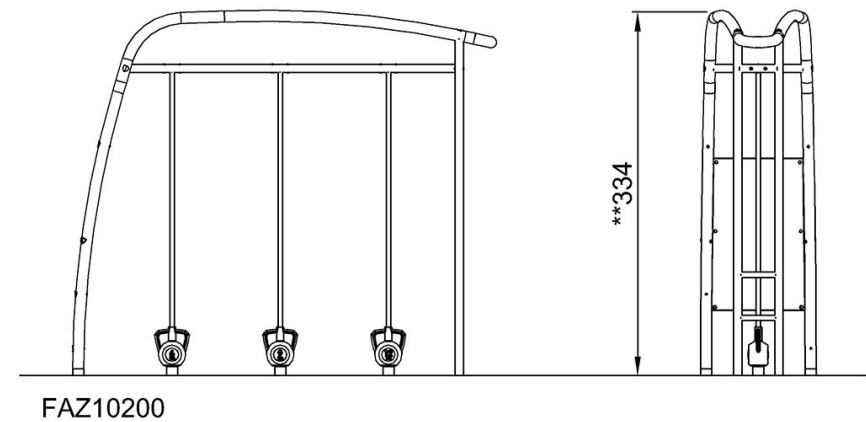
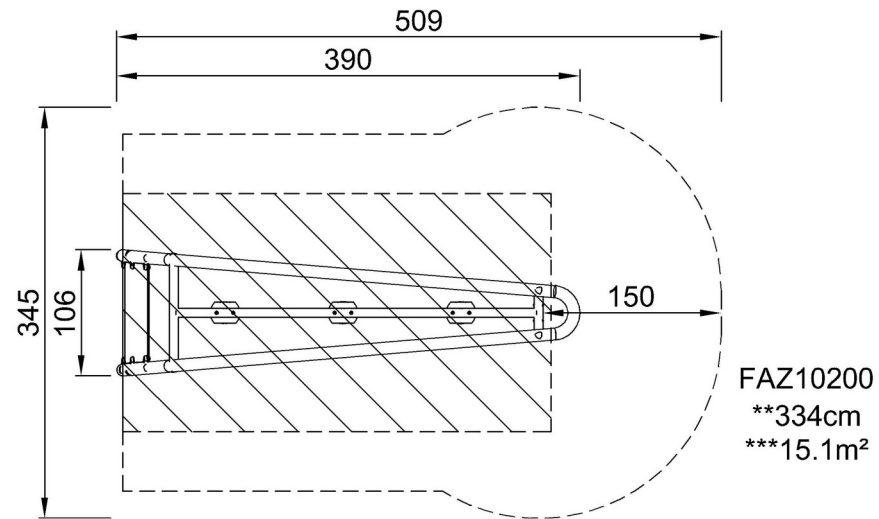

[Click to see TOP VIEW](#)

[Click to see SIDE VIEW](#)