

Triple Tower Stairs

PCM310921

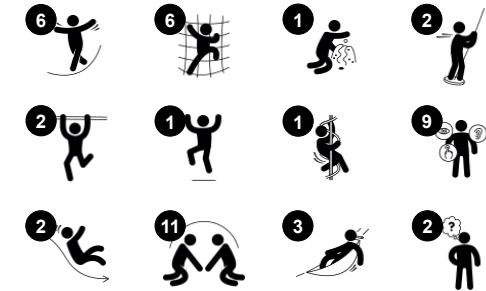

Item no. PCM310921-0904	
General Product Information	
Dimensions LxWxH	855x508x410 cm
Age group	4+
Play capacity (users)	36
Color options	



The play unit offers many levels of play: from the inclined climbing net up to the lower platform, from which the child can take the stomach-tickling slide down to the ground or enjoy the rotating movement of the Curly Climber back to the ground. An alternative route is to venture onto the wobble bridge, using the full physical concentration on

balancing to the platform of the stairway. The second half leads to the roomy top of the mega deck, perfect for groups to socialise and play on an elevated level, from which they can choose their way to the ground on either, a curved, bumpy slide or a dare devil pair of banister bars at full speed. An alternative route up to the mega deck platform is up the curved

tower net where climbing will challenge the physical and coordination skills. Under the platform a nice seat and a rocking hammock makes a meeting point for all.

Triple Tower Stairs

PCM310921



Panels of 19mm EcoCore™. EcoCore™ is a highly durable, eco friendly material, which is not only recyclable after use, but also consists of material produced from +95% recycled post consumer material from food packing waste.



All decks are supported by unique designed low-carbon aluminum profiles with multiple attachment options. The grey colored molded decks are made of 75% post-consumer waste PP material with a non-skid pattern and texture surface.



Main posts with hot dip galvanized steel footing are available in different materials: Pressure impregnated pine wood posts. Pre-galvanized inside and outside with powder coated top finish steel posts. Lead free aluminum with color anodized top finish. Greenline TexMade posts of 95% post-consumer recycled PE and textile waste.

Item no. PCM310921-0904	
Installation Information	
Max. fall height	276 cm
Safety surfacing area	75.7 m ²
Total installation time	41.5
Excavation volume	1.17 m ³
Concrete volume	0.27 m ³
Footing depth (standard)	90 cm
Shipment weight	1,493 kg
Anchoring options	In-ground ✓ Surface ✓

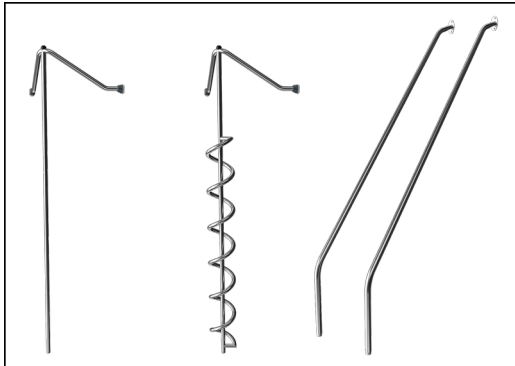

The stainless-steel activities are made of high-quality stainless steel. The steel is cleaned by a total pickling process after manufacturing to ensure a smooth and clean gliding surfaces.



The slides can be chosen in six different colors and three materials: Straight or curved one-piece molded PE slides, made from 33% recycled post-consumer materials in different colours. Combined EcoCore™ sides and stainless-steel. Full stainless steel in one piece design for more vandalism proof solutions.



KOMPAN GreenLine versions are designed with ultimate environmentally friendly materials with lowest possible CO2e emission factor. TexMade post, EcoCore™ panels of 95% post-consumer recycled waste and molded PP decks.



Sustainability Data

PCM310921



Cradle to Gate A1-A3	Total CO ₂ emission	CO ₂ e/kg	Recycled materials
	kg CO ₂ e	kg CO ₂ e/kg	%
PCM310921-0951	2,241.70	1.81	70.10
PCM310921-0904	2,702.00	2.55	56.90

The overall framework applied for these factors is the Environmental Product Declaration (EPD), which quantifies "environmental information on the life cycle of a product and enable comparisons between products fulfilling the same function" (ISO, 2006). This follows the structure and applies a Life-Cycle Assessment approach to the entire Product stage from raw material through manufacturing (A1-A3))

Kompan A/S
C.F. Tietgens Boulevard 32C
DK-5220 Odense SØ
Denmark



Verification of CO₂ calculation of: Play systems



Data version no. 2023-10-05

The CO₂ calculation and data are in compliance with the principles of a carbon footprint impact according to the GHG protocol (Greenhouse Gas Protocol), Scope 3, cradle to gate related to all individual components in the product category: "Play systems" represented by item no.: PCM200321-0950.

(Scope 3 emissions include emission sources in the upstream and downstream value chain).

Date: 30. October 2023 | Valid until: 30. October 2025

Verified by:

Julie Marie Vejsgaard Larsen, LCA & EPD Consultant

Verification based on report: Validation of CO₂ calculation of 9 categories of Kompan product line, version 1.0, prepared by: Bureau Veritas HSE, Denmark: Julie M. V. Larsen.

Publication date: 30. October 2023

By Bureau Veritas HSE
www.bureauveritas.dk
+45 7731 1000



Triple Tower Stairs

PCM310921

* Max fall height | ** Total height | *** Safety surfacing area

* Max fall height | ** Total height

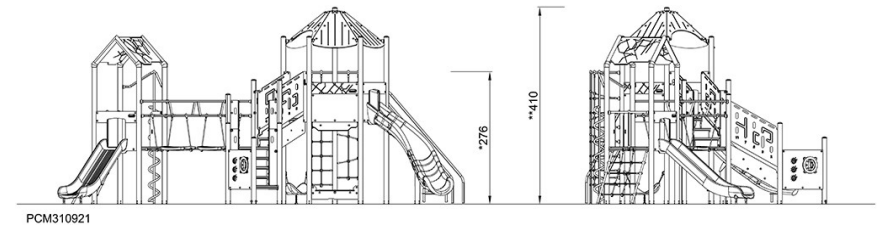
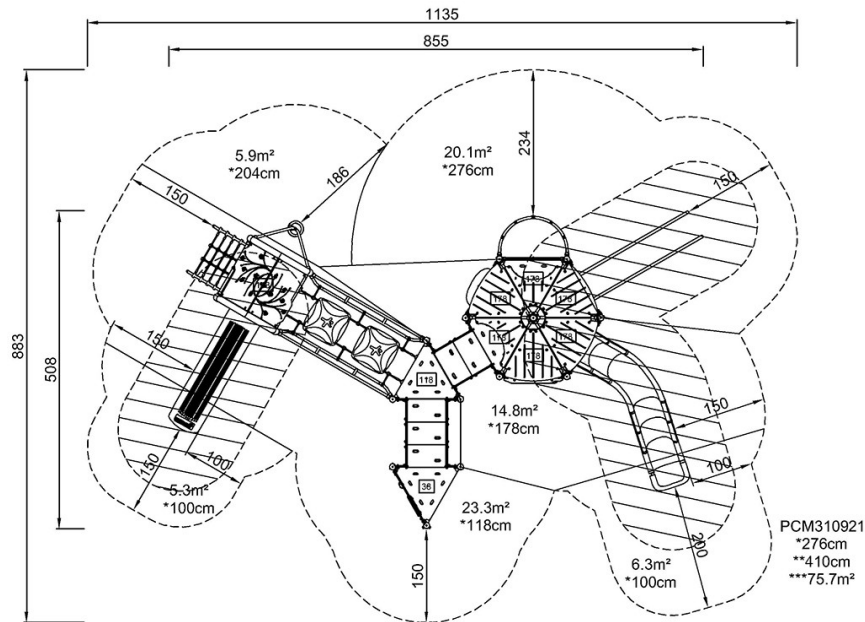

[Click to see TOP VIEW](#)

[Click to see SIDE VIEW](#)