

Little Elephant

M189



Item no. M18901-01P

General Product Information

Dimensions LxWxH	40x80x86 cm
Age group	1+
Play capacity (users)	1
Colour options	



The little blue Elephant is a rocker to stand on, with space to be seated on the oval platform as well. Standing up and rocking gives a feeling of control of cause and effect to the child. The ear has got a red play sphere which can be turned and moved up and down. Cooperation between two children standing on each their side rocking took place repeatedly in the

observations nursery for this product.

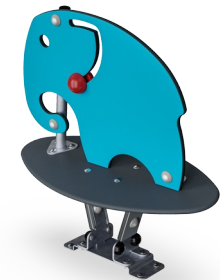

Little Elephant

M189



Theme

Cognitive: suggests a theme and supports dramatic play, which stimulates language and communication skills.



Rocking movement

Physical: response to movements adds to spatial awareness and sense of balance. These are fundamental motor skills that help the child's ability to sit still on a chair which takes a good sense of balance. **Cognitive:** trains the understanding of cause and effect: when I move my body, the spring responds with movement.



Play sphere

Social-Emotional: can be played from both sides, encouraging cooperation. **Cognitive:** cause and effect understanding. **Creative:** leave a mark and place the spheres at different positions.

Little Elephant

M189



Panels of 19mm EcoCore™. EcoCore™ is a highly durable, eco friendly material, which is not only recyclable after use, but also consists of material produced from +95% recycled post consumer material from food packing waste.



Seat is made of HPL with a thickness of 17.8mm with a very high wearing strength and a unique KOMPAN nonskid surface texture.



The rocking movement over axis is made by heavy duty scaled ROSTA torsion spring element. The ROSTA element works without any noise and requires low maintenance.



The steel surfaces are hot dip galvanised inside and outside with lead free zinc. The galvanisation has excellent corrosion resistance in outside environments and requires low maintenance.

Item no. M18901-01P	
Installation Information	
Max. fall height	60 cm
Safety surfacing area	10.4 m ²
Total installation time	2.6
Excavation volume	0.12 m ³
Concrete volume	0.00 m ³
Footing depth (standard)	44 cm
Shipment weight	30 kg
Anchoring options	In-ground ✓ Surface ✓
Warranty Information	
EcoCore HDPE	Lifetime
Hot dip galvanised steel	Lifetime
Spare parts guaranteed	10 years
Springs	5 years



Sustainability Data

M189



Cradle to Gate A1-A3	Total CO ₂ emission	CO ₂ e/kg	Recycled materials
	kg CO ₂ e	kg CO ₂ e/kg	%
M18901-01P	62.47	2.40	38.84

The overall framework applied for these factors is the Environmental Product Declaration (EPD), which quantifies "environmental information on the life cycle of a product and enable comparisons between products fulfilling the same function" (ISO, 2006). This follows the structure and applies a Life-Cycle Assessment approach to the entire Product stage from raw material through manufacturing (A1-A3))

Kompan A/S
 C.F. Tietgens Boulevard 32C
 DK-5220 Odense SØ
 Denmark



Verification of CO₂ calculation of: Themed play systems



Data version no. 2023-10-05

The CO₂ calculation and data are in compliance with the principles of a carbon footprint impact according to the GHG protocol (Greenhouse Gas Protocol), Scope 3, cradle to gate related to all individual components in the product category: "Themed play systems" represented by item no.: MSC641100-3717P.

(Scope 3 emissions include emission sources in the upstream and downstream value chain).

Date: 30. October 2023 | Valid until: 30. October 2025

Verified by:

Julie Marie Vejsgaard Larsen, LCA & EPD Consultant

Verification based on report: Validation of CO₂ calculation of 9 categories of Kompan product line, version 1.0, prepared by: Bureau Veritas HSE, Denmark: Julie M. V. Larsen.

Publication date: 30. October 2023

By Bureau Veritas HSE
 www.bureauveritas.dk
 +45 7731 1000



Little Elephant

M189

* Max fall height | ** Total height | *** Safety surfacing area

* Max fall height | ** Total height

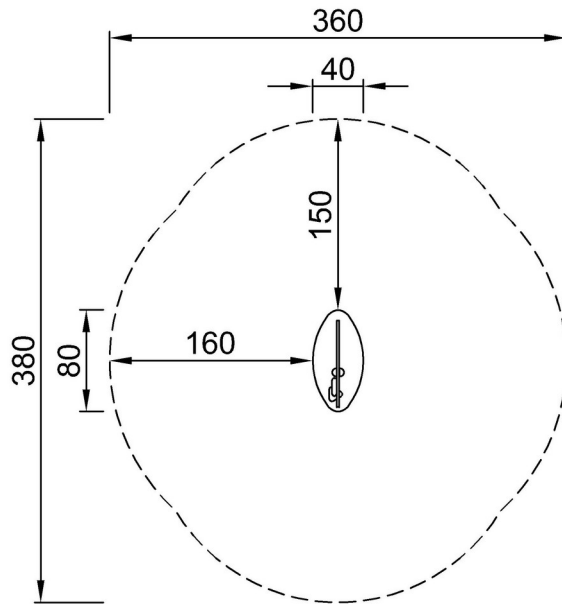

M18901P
*60cm
**86cm
***10.4m²



M18901P

[Click to see TOP VIEW](#)

[Click to see SIDE VIEW](#)