

# Four Tower with Roofs

PCM410121



Item no. PCM410121-0951	
General Product Information	
Dimensions LxWxH	726x660x396 cm
Age group	4+
Play capacity (users)	31
Colour options	



This four tower structure creates a fun environment that inspires play, encourages movement, and sets the challenges that children in this age group love. For school age children, there is nothing like varied, physical and challenging play to make them happy and attracted to this structure. The closed courtyard of play on more levels provides balancing,

climbing and sliding activities. A whole world of social interaction goes on in the hammocks, tic-tac-toe panel and hour glass with timer knobs on ground level. The variation in activities make children play for a long time, again and again. Apart from being great fun for lots of children, this play structure trains the arm, leg and core muscles when they climb and hang

from their knees the net rungs. Gross motor skills are stimulated through climb, balance and slide movements on towers, bridges and nets.

# Four Tower with Roofs

PCM410121



## Banister bars

**Physical:** coordination is supported when going down, as well as arm and core muscles. Landing strengthens bone density, which is built for life in childhood. **Social-Emotional:** turn-taking and risk-taking.



## Cave bridge

**Physical:** crawling in the cave bridge net develops cross-body coordination, proprioception and spatial awareness. **Social-Emotional:** cooperation and socializing with others in and around the net, turn-taking.



## Plank bridge

**Physical:** balancing across the plank develops the vestibular system as well as cross coordination. **Social-Emotional:** passing other children takes co-operation and teaches children turn-taking skills.



## Rapella

**Physical:** supports cross coordination, proprioception and sense of space. Leg and core muscles are used intensely. Upper body muscles are developed when children pull themselves upwards in the rope. **Social-Emotional:** turn-taking and self-regulation, both important life skills.



## Slide

**Physical:** sliding develops spatial awareness and a sense of balance. Furthermore, the core muscles are trained when sitting upright going down. **Social-Emotional:** empathy stimulated by turn-taking.



## Hammock

**Physical:** coordination and sense of balance when swaying. **Social-Emotional:** meeting, pushing friends gently back and forth, turn-taking. **Cognitive:** for toddlers cause and effect understanding.



## Tower net

**Physical:** the children have fast access up the horizontal rungs, and a slower climb up the sloping rungs. The net can be climbed from both sides, levelling the challenge. Cross coordination, and arm and leg muscles are trained. **Social-Emotional:** the two-sided net and spaciousness allows for social interaction. **Cognitive:** logical thinking when planning how to best enter the platform from the net.

# Four Tower with Roofs

PCM410121

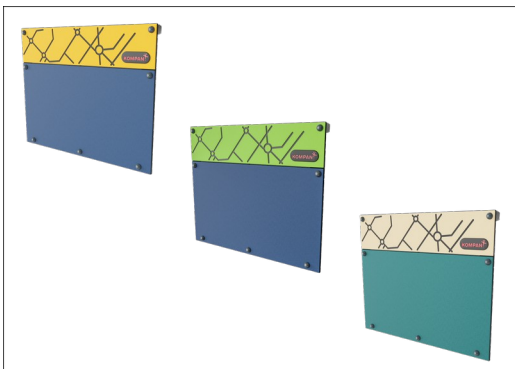

Panels of 19mm EcoCore™. EcoCore™ is a highly durable, eco friendly material, which is not only recyclable after use, but also consists of material produced from +95% recycled post consumer material from food packing waste.



All decks are supported by unique designed low-carbon aluminum profiles with multiple attachment options. The grey colored molded decks are made of 75% post-consumer waste PP material with a non-skid pattern and texture surface.



Main posts with hot dip galvanized steel footing are available in different materials: Pressure impregnated pine wood posts. Pre-galvanized inside and outside with powder coated top finish steel posts. Lead free aluminum with color anodized top finish. Greenline TexMade posts of 95% post-consumer recycled PE and textile waste.

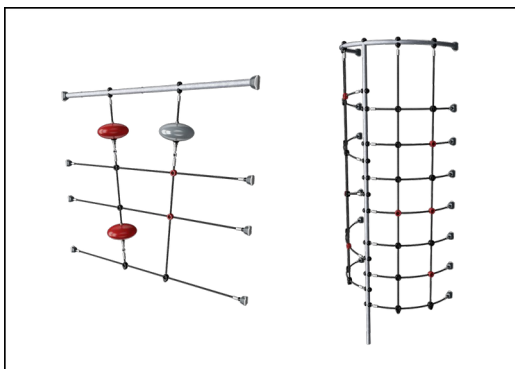

Ropes of UV-stabilized PES rope strands with inner steel cable reinforcement. The polyester yarn is made from +95% post-consumer materials and is inductively melted onto each strand.



The slides can be chosen in six different colors and three materials: Straight or curved one-piece molded PE slides, made from 33% recycled post-consumer materials in different colours. Combined EcoCore™ sides and stainless-steel. Full stainless steel in one piece design for more vandalism proof solutions.



KOMPAN GreenLine versions are designed with ultimate environmentally friendly materials with lowest possible CO2e emission factor. TexMade post, EcoCore™ panels of 95% post-consumer recycled waste and molded PP decks.

Item no. PCM410121-0951

### Installation Information

Max. fall height	284 cm
Safety surfacing area	75.5 m <sup>2</sup>
Total installation time	36.0
Excavation volume	1.09 m <sup>3</sup>
Concrete volume	0.24 m <sup>3</sup>
Footing depth (standard)	90 cm
Shipment weight	1,522 kg
Anchoring options	Surface ✓ In-ground ✓

### Warranty Information

EcoCore HDPE	Lifetime
Post	10 years
PP Decks	10 years
Ropes & nets	10 years
Spare parts guaranteed	10 years



# Sustainability Data

PCM410121



Cradle to Gate A1-A3	Total CO <sub>2</sub> emission	CO <sub>2</sub> e/kg	Recycled materials
	kg CO <sub>2</sub> e	kg CO <sub>2</sub> e/kg	%
<b>PCM410121-0951</b>	2,108.12	2.02	68.79
<b>PCM410121-0905</b>	2,553.39	3.12	49.51

The overall framework applied for these factors is the Environmental Product Declaration (EPD), which quantifies "environmental information on the life cycle of a product and enable comparisons between products fulfilling the same function" (ISO, 2006). This follows the structure and applies a Life-Cycle Assessment approach to the entire Product stage from raw material through manufacturing (A1-A3))

**Kompan A/S**  
 C.F. Tietgens Boulevard 32C  
 DK-5220 Odense SØ  
 Denmark



## Verification of CO<sub>2</sub> calculation of: Play systems



Data version no. 2023-10-05

The CO<sub>2</sub> calculation and data are in compliance with the principles of a carbon footprint impact according to the GHG protocol (Greenhouse Gas Protocol), Scope 3, cradle to gate related to all individual components in the product category: "Play systems" represented by item no.: PCM200321-0950.

(Scope 3 emissions include emission sources in the upstream and downstream value chain).

**Date: 30. October 2023 | Valid until: 30. October 2025**

Verified by:

Julie Marie Vejsgaard Larsen, LCA & EPD Consultant

Verification based on report: Validation of CO<sub>2</sub> calculation of 9 categories of Kompan product line, version 1.0, prepared by: Bureau Veritas HSE, Denmark: Julie M. V. Larsen.

**Publication date: 30. October 2023**

By Bureau Veritas HSE  
 www.bureauveritas.dk  
 +45 7731 1000



# Four Tower with Roofs

PCM410121

\* Max fall height | \*\* Total height | \*\*\* Safety surfacing area

\* Max fall height | \*\* Total height

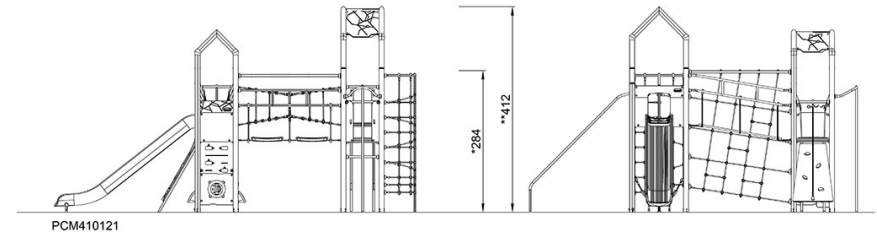
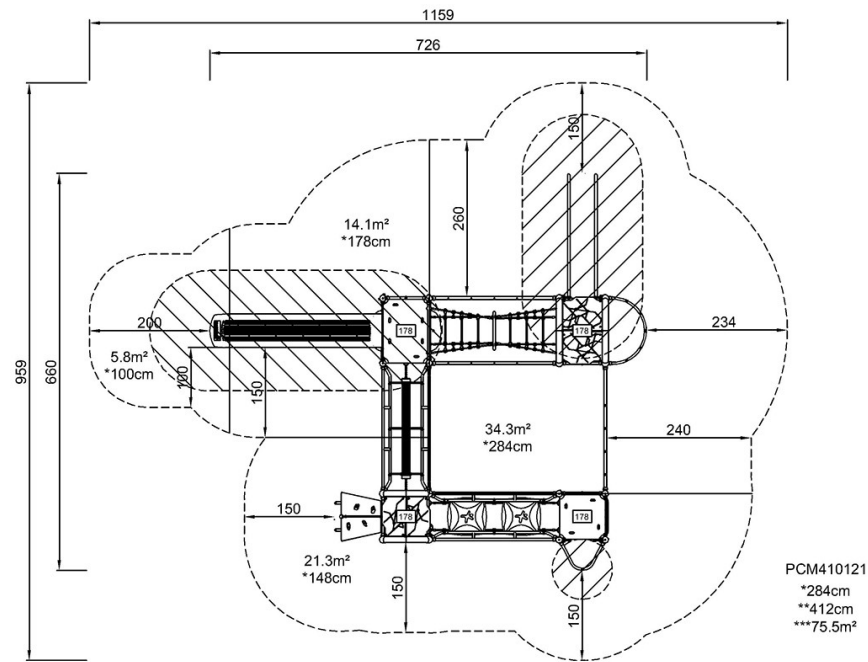

[Click to see TOP VIEW](#)

[Click to see SIDE VIEW](#)