

Cocowave Pendulum Swing

M984

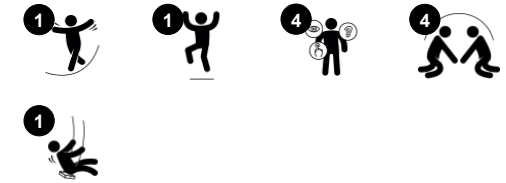

Item no. M98401-1011	
General Product Information	
Dimensions LxWxH	620x270x363 cm
Age group	6+
Play capacity (users)	8
Colour options	



Whether it is swinging - mildly or wildly - the Cocowave Pendulum Swing is an irresistible invitation for all children to play. A robust, oblong coconut rope, allows for swinging from a seated, lying, or standing position. This gives groups of varying sizes, ages, and physical abilities a more inclusive play environment. It takes teamwork to make the swing move, and

this stimulates important social-emotional skills. Apart from being fun, swinging on the Cocowave swing also trains muscles and important motor skills, such as balance, coordination, and sense of space. These are important to train vestibular skills that matter profoundly for e.g. navigating traffic safely. The tickling, challenging feeling of speed and height

stimulates children's self-esteem, risk management, and other important social-emotional life skills. See more Playground Swings here.



Cocowave Pendulum Swing

M984



Chains

Physical: space between chains supports a comfortable grip for use of muscle strength when standing up swinging.



Cocowave swing

Physical: supports muscle strength, sense of balance and space. Bone density is built up when children swing and jump on-off. **Social-Emotional:** height and speed of swinging supports self-esteem. When listening and negotiating, children develop their empathy and cooperation skills. **Cognitive:** height and speed of swinging helps children to judge distances and heights.



Coconut rope

Physical: balance and coordination is supported when walking the swaying rope. A good sense of balance transfers to other skills such as sitting still on a chair. **Social-Emotional:** children swaying together on the rope experience their own and others' movements. This spurs cooperation and consideration, e.g. when passing others on the rope.



Connectors in the side of the rope

Physical: allow for foot position between connectors resulting in ease of use when standing up swinging. Develops muscle strength. **Social-Emotional:** room for different body positions like standing, sitting and lying.

Cocowave Pendulum Swing

M984



The steel pipes are hot-dip galvanised inside and outside with lead-free zinc. The galvanisation has excellent corrosion resistance in outside environments and requires low maintenance.



Galvanisation is manufactured with a two-step process which includes light grinding and clean sweeping, which is then finished with a top powder coating to 70-120 µm thickness.



The uniquely designed swing hangers are manufactured from stainless steel and anti-twist function. The hangers are attached to the cross beam by a bolt through connection to ensure high durability.



The rope of the pendulum swing is made of polypropylene (PP) rope in Coconut style with a square shape of 14x14cm. The ends of the Coconut rope are closed by steel clamps and sealed by a glued-on shrinkable tubing. The last 10cm of the rope ends are cut open to make a tassel with bumper function to fulfil global safety requirements.



The chain/ropes are attached to the Coconut rope by KOMPAN's swivel bushings which are made of stainless steel with bronze bearings. The swivels have an outer cover which is manufactured from black PUR. The usage of side mounted swivels provides frictionless movement, eliminates fingers and feet entrapments and enlarges the standing surface on top of the rope.

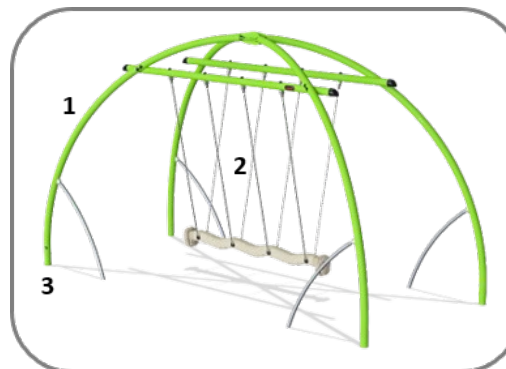

The Cocowave pendulum swing is available in multiple finishes or colour options. These include galvanised steel with optional powder coated top finish in lime green colour, rope or stainless steel chain suspensions or in-ground or surface anchoring.

Item no. M98401-1011	
Installation Information	
Max. fall height	179 cm
Safety surfacing area	22.9 m ²
Total installation time	9.6
Excavation volume	2.08 m ³
Concrete volume	1.12 m ³
Footing depth (standard)	100 cm
Shipment weight	620 kg
Anchoring options	In-ground ✓ Surface ✓
Warranty Information	
Chains	10 years
Galvanised Steel	Lifetime
Movable Parts	2 years
Ropes & Nets	10 years
Spare Parts Guarantee	10 years



Sustainability Data

M984



Cradle to Gate A1-A3	Total CO ₂ emission	CO ₂ e/kg	Recycled materials
	kg CO ₂ e	kg CO ₂ e/kg	%
M98401-1011	1,249.33	3.19	43.25

The overall framework applied for these factors is the Environmental Product Declaration (EPD), which quantifies "environmental information on the life cycle of a product and enable comparisons between products fulfilling the same function" (ISO, 2006). This follows the structure and applies a Life-Cycle Assessment approach to the entire Product stage from raw material through manufacturing (A1-A3))

Kompan A/S
C.F. Tietgens Boulevard 32C
DK-5220 Odense SØ
Denmark



Verification of CO₂ calculation of: Freestanding play equipment



Data version no. 2023-10-05

The CO₂ calculation and data are in compliance with the principles of a carbon footprint impact according to the GHG protocol (Greenhouse Gas Protocol), Scope 3, cradle to gate related to all individual components in the product category: "Freestanding play equipment" represented by item no.: KSW92011-0910.

(Scope 3 emissions include emission sources in the upstream and downstream value chain).

Date: 30. October 2023 | Valid until: 30. October 2025

Verified by:

Julie Marie Vejsgaard Larsen, LCA & EPD Consultant

Verification based on report: Validation of CO₂ calculation of 9 categories of Kompan product line, version 1.0, prepared by: Bureau Veritas HSE, Denmark: Julie M. V. Larsen.

Publication date: 30. October 2023

By Bureau Veritas HSE
www.bureauveritas.dk
+45 7731 1000



Cocowave Pendulum Swing

M984

* Max fall height | ** Total height | *** Safety surfacing area

* Max fall height | ** Total height

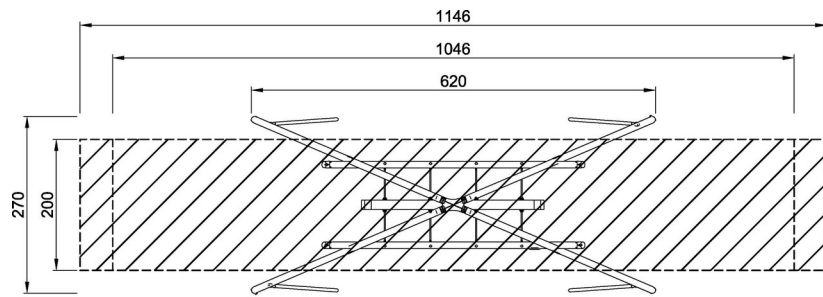

M98401
*179cm
**363cm
***22.9m²

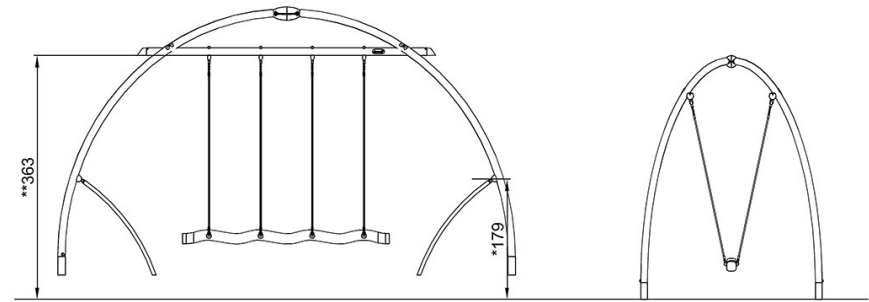

M98401

[Click to see TOP VIEW](#)

[Click to see SIDE VIEW](#)