

Rainer

PCE210221

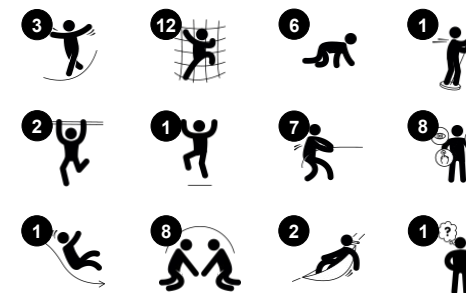

Item no. PCE210221-0901	
General Product Information	
Dimensions LxWxH	656x626x572 cm
Age group	6+
Play capacity (users)	24
Color options	



The Rainer, with its impressive height, attracts children again and again. The wide array of fun activities ensures hours of play. The variety of climbing, sliding and swaying play events trains cross-body coordination and balance, which are both important for life skills like traffic safety. The sturdy climbing wall panel adds the opportunity to take a break with friends on the

way up or down. The swaying shells under the platform offer a nice meeting spot. The inclined net brings climbers up to the banister bar and slide platforms offers soft-cross body coordination training. The banister bars and the tall slide are thrilling rewards for the climb. The Rainer is irresistibly climbable all over, inside out, meaning play opportunities everywhere,

for many levels of development. It is a compact play experience with loads of challenges.

Rainer

PCE210221

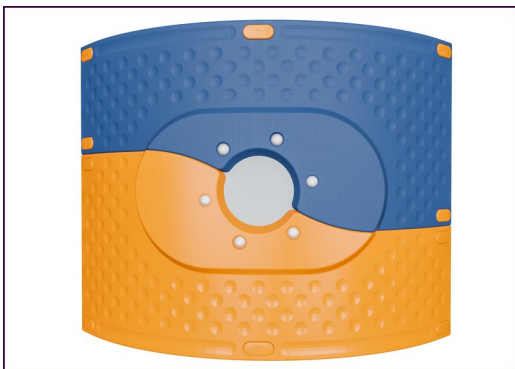

The Curved ELEMENTS panels are moulded of UV stabilised recyclable PE using 33% post-consumer recycled material. With multiple options for in-build play features that also ensures a strong panel solution. Straight panels are made of KOMPAN 19mm HDPE EcoCore™ which is a highly durable, ecofriendly and recyclable material made from +95% PCM.



The climbing elements displayed are moulded from 33% post-consumer recycled materials in one piece, with a minimum 5mm wall thickness. The climbing elements are made of recyclable PE which has a high impact resistance across a wide temperature span which ensures vandal resistance in all locations.

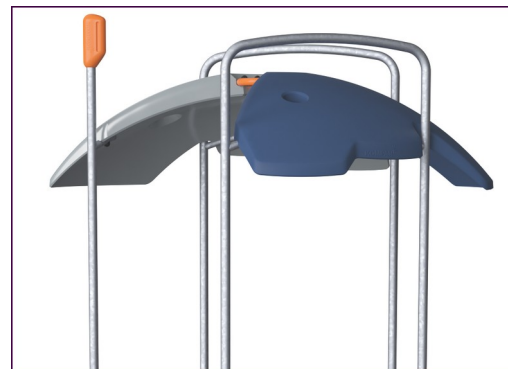

The ELEMENTS roofs are made of recyclable PE made from 33% post consumer recycled materials with a minimum wall thickness of 5 mm to ensure high durability in all climates around the world. The steel pipes are hot dip galvanised inside and outside for maximum durability.

Item no. PCE210221-0901	
Installation Information	
Max. fall height	238 cm
Safety surfacing area	63.6 m ²
Total installation time	31.1
Excavation volume	1.47 m ³
Concrete volume	0.34 m ³
Footing depth (standard)	85 cm
Shipment weight	972 kg
Anchoring options	Surface ✓ In-ground ✓



The main posts are made of high quality pregalvanized steel with powder coated top finish. Post tops are closed with caps of UV stabilized nylon (PA6). The grey colored molded decks are made of 75% post-consumer waste PP material with a non-skid pattern and texture surface. All decks are supported by unique designed low-carbon aluminum profiles with multiple attachment options.



ELEMENTS rubber membranes are conveyor belt made of layers of rubber mixed of natural rubber and SBR rubber, and embedded with layers of armouring made of woven PE and PA. The thickness 8mm ensures high durability in any environment.



ELEMENTS ropes has six-stranded steel wires and a steel wire core. Each strand is tightly wrapped with PES yarn, which is made from +95% post consumer materials. The yarn is then melted onto each individual strand making the ropes highly wear- and vandalism-resistant.



Sustainability Data

PCE210221



Cradle to Gate A1-A3

Total CO₂ emission

CO₂e/kg

Recycled materials

kg CO₂e

kg CO₂e/kg

%

PCE210221-0901

2,153.60

2.87

47.40

The overall framework applied for these factors is the Environmental Product Declaration (EPD), which quantifies "environmental information on the life cycle of a product and enable comparisons between products fulfilling the same function" (ISO, 2006). This follows the structure and applies a Life-Cycle Assessment approach to the entire Product stage from raw material through manufacturing (A1-A3))

Kompan A/S

C.F. Tietgens Boulevard 32C
DK-5220 Odense SØ
Denmark

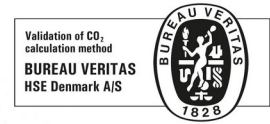

Verification of CO₂ calculation of: Play systems



Data version no. 2023-10-05

The CO₂ calculation and data are in compliance with the principles of a carbon footprint impact according to the GHG protocol (Greenhouse Gas Protocol), Scope 3, cradle to gate related to all individual components in the product category: "Play systems" represented by item no.: PCM200321-0950.

(Scope 3 emissions include emission sources in the upstream and downstream value chain).

Date: 30. October 2023 | Valid until: 30. October 2025

Verified by:

Julie Marie Vejsgaard Larsen, LCA & EPD Consultant

Verification based on report: Validation of CO₂ calculation of 9 categories of Kompan product line, version 1.0, prepared by: Bureau Veritas HSE, Denmark: Julie M. V. Larsen.

Publication date: 30. October 2023

By Bureau Veritas HSE

www.bureauveritas.dk

+45 7731 1000



Rainer

PCE210221

* Max fall height | ** Total height | *** Safety surfacing area

* Max fall height | ** Total height

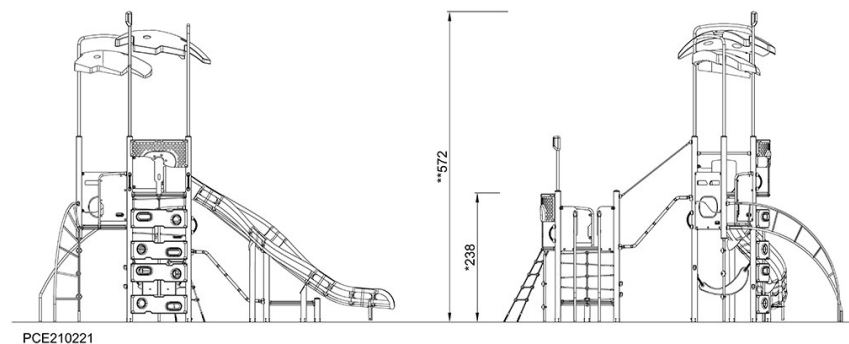
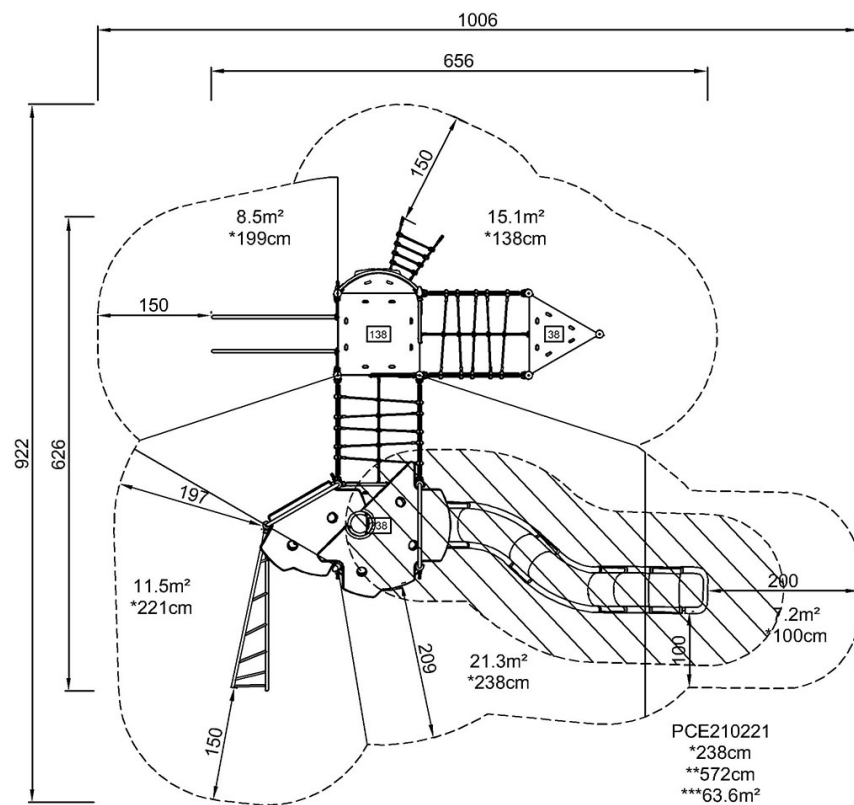

[Click to see TOP VIEW](#)

[Click to see SIDE VIEW](#)