

Développé Épaules

FSW40300

KOMPAN[®]



Doté d'une charge réglable, l'appareil Développé Épaules permet un entraînement de musculation authentique ciblant les épaules et les triceps. Ses poignées ergonomiques, faciles à utiliser et offrant plusieurs types de prises, permettent différentes positions d'exercice tout en s'adaptant parfaitement à des utilisateurs de toutes tailles. Conçue pour

garantir une sécurité optimale, la machine intègre l'ensemble des butées mécaniques à l'intérieur du carter, éliminant ainsi tout risque de pincement.

Référence FSW40300-0001	
Informations générales	
Dimensions LxPxH	125x157x123 cm
Age minimum	13+
Capacité d'accueil (utilisateurs)	1
Options de couleurs	



Développé Épaules

FSW40300

KOMPAN



All mechanical stops are fully enclosed within the cover. The adjustable weight, featuring internal end stops and indexed positions, moves on rollers within an enclosed groove in an aluminium profile. As a result, entrapment is not possible, making it extremely safe to use and providing protection against the elements and unwanted abuse.



The weight on each side can be adjusted in 8 steps of 2,5 kg, providing a training weight from 5 to 40kg. The patent pending system is intuitive to use, eliminating the need for traditional pins that can get lost or stuck. Pull the handle and move the weight to quickly select the desired load.



The seat is made of blowmolded PE and mounted directly onto the steel frame, making it highly durable and resistant to wear and tear. To ensure comfort and a great user experience, the seat features an ergonomic groove. A seat height of 43 cm ensures easy access and transfer for wheelchair users.



The machine features low operating noise thanks to an internal end stop made from TPE (thermoplastic elastomer). The damper absorbs impact energy from the weight with minimal rebound, reducing noise and vibration and ensuring a quieter, more controlled training experience.



Handles
The ergonomically shaped handles feature multiple grip areas to support adaptable training. This allows users between 140–205 cm in height to perform exercises with correct ergonomics while enabling a wide variety of exercises that target different muscle groups. The handles are made from cast aluminium with a grip texture finish.



The unilateral movement design ensures that each arm works independently, preventing compensation by the stronger side. The independent movement also allows for greater flexibility, enabling multiple exercise variations and supporting inclusive training for users of different abilities.

Référence FSW40300-0001

Installation

Hauteur de Chute Max.	43 cm
Zone de sécurité	17,2 m ²
Temps total d'installation	5,9 heures
Volume d'excavation	0,00 m ³
Volume de béton	0,00 m ³
Profondeur ancrage	0 cm
Poids d'expédition	308 kg
Options d'ancrage	

Garantie

Métal galvanisé / peint	10 ans
Aluminium	15 ans
Pièces mobiles	2 ans
Pièces creuses en PE	10 ans
Dispo pièces après arrêt fab.	10 ans

EN
16630
compliant

Données sur le développement durable

FSW40300



Berceau à porte A1-A3	Émissions totales de CO ₂	CO ₂ e/kg	Matériaux recyclés
	kg CO ₂ e	kg CO ₂ e/kg	%
FSW40300-0001	1.388,88	6,49	44,59

Le cadre général appliqué est la Déclaration Environnementale Produit (DEP), qui quantifie « les informations environnementales sur le cycle de vie d'un produit et permet des comparaisons entre produits remplissant la même fonction » (ISO, 2006). Cela suit la structure et applique une approche d'évaluation du cycle de vie à l'ensemble de l'étape du produit, de la matière première à la fabrication (A1-A3))



Independent review certificate

Kompan A/S
C. F. Tietgens Blvd. 32C, 5220 Odense SØ

Bureau Veritas hereby attests that the CO₂e-calculations (covering materials, processing, waste and transport) done by Kompan for "Fitness", meet the requirements set by the listed standard.

Kompan A/S uses a selection of EPDs and emission factors from the Life Cycle Assessment database Ecoinvent 3.11. These values are reported as kg CO₂e, with all other impact categories excluded in line with the scope of ISO 14067:2018. The emission factors cover, material use, manufacturing processes, transport to Kompan, and electricity used during manufacturing. The presented emissions fall under GHG Protocol scope 3 emissions. Scope 1 and 2 are not presented. Scope 3 emissions include emission sources in the upstream value chain of a company, downstream emissions are excluded in this analysis.

Method: ISO 14067:2018 using GHG protocol guidance documents, reported as kg CO₂e.

Object

The verification has been done on the one pager "FAZ10100-0900" version: 27-10-2025. The supporting documentation "KOMPAN data_updated emissions factors_2025_V2" and "Emissions factors, EPD's and ecoinvent 3.11_2025" was also reviewed and approved.

Declaration

The review has been completed as a critical review with a limited assurance. I hereby confirm that nothing has come to the reviewer's attention which would lead to conclude that the study does not give an accurate depiction or isn't completed following method of the CO₂e calculation, the requirements of ISO 14067:2018, and 14071:2024, in the above referenced documentation.

Note: This verification only covers calculation elements according to method described in ISO 14067:2018 and may not be seen as a Life Cycle Assessment according to ISO 14067:2018.

Ref.: Kompan_Verification report 2025, 28-10-2025

Date of certificate: 29-10-2025

Expire date: 29-10-2027

Verified by: Julie Marie Vejsgaard Larsen, Environmental Auditor

Signature:

Développé Épaules

FSW40300

KOMPANI

* Hauteur de chute maximale | ** Hauteur totale | *** Zone de sécurité

* Hauteur de chute maximale | ** Hauteur totale

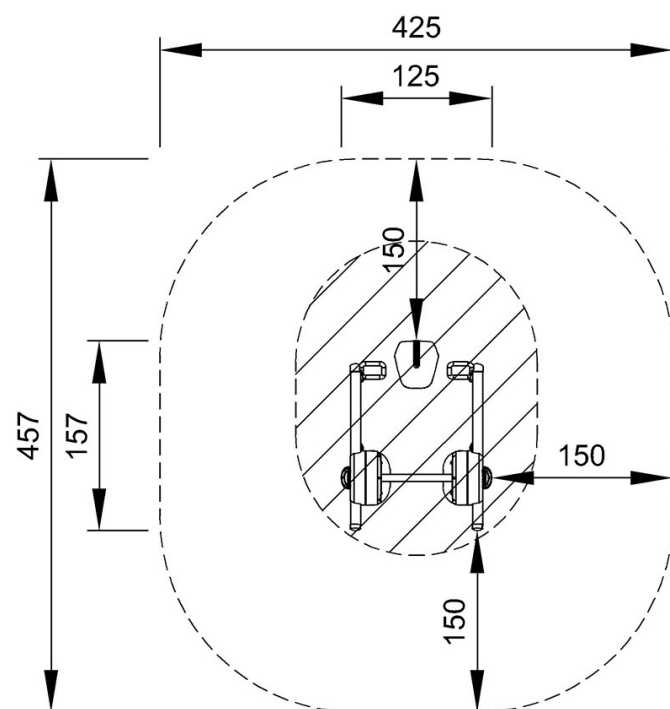

FSW40300
*43cm
**123cm
***17.2m²

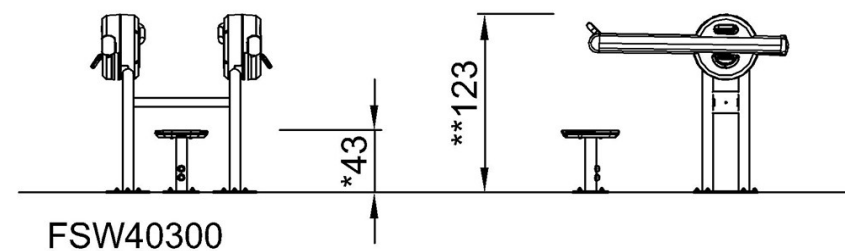

[Cliquez pour voir le rapport VUE DE DESSUS](#)

[Cliquez pour voir le rapport VUE LATÉRALE](#)