



Play Tower with 2.5m Swing

KPL1017



Item no. KPL101711-0902	
General Product Information	
Dimensions LxWxH	469x375x346 cm
Age group	4+
Play capacity (users)	5
Colour options	 

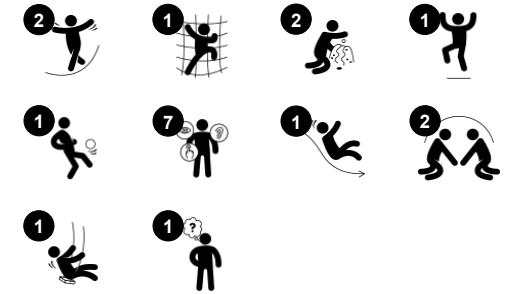

This play tower offers the perfect combination of climbing, swinging and sliding which is a great recipe for great fun for school age children. The platform with the slide can be entered by the climbing wall and from the platform a stomach-tickling slide ride takes the child back to the ground. The swing is great fun and a feature that can be used by all

generations, seated, lying on the stomach or standing.

Play Tower with 2.5m Swing

KPL1017



Ring game

Social-Emotional: cooperating from both sides on running rings up and down trains turn-taking and cooperation skills. **Cognitive:** figuring out how to turn the ring to make it fit the holes and move up or down trains logical skills. **Creative:** leaving rings in new positions leaves a mark in the playground.



Swing seat

Physical: balance, coordination and spatial awareness are developed when swinging. These are necessary skills for judging distances and navigating. The swinging movement trains the arm, leg and core muscles, and strengthens bone density when jumping off. **Cognitive:** cause and effect understanding and thinking skills for younger children when swinging.



Climbing wall

Physical: develops children's cross coordination, eye-hand coordination, and muscle strength when climbing. **Social-Emotional:** two-sided climb invites cooperation.



Slide

Physical: sliding develops spatial awareness and a sense of balance. Furthermore, the core muscles are trained when sitting upright going down. **Social-Emotional:** empathy stimulated by turn-taking.

Play Tower with 2.5m Swing

KPL1017



Panels of 19mm EcoCore™. EcoCore™ is a highly durable, eco friendly material, which is not only recyclable after use, but also consists of material produced from +95% recycled post consumer material from food packing waste.



The main tower posts of either pine wood or aluminium are all equipped with hot dip galvanised steel footings. The steel footings elevates the posts 20mm from ground level to avoid contact with surfacing material.

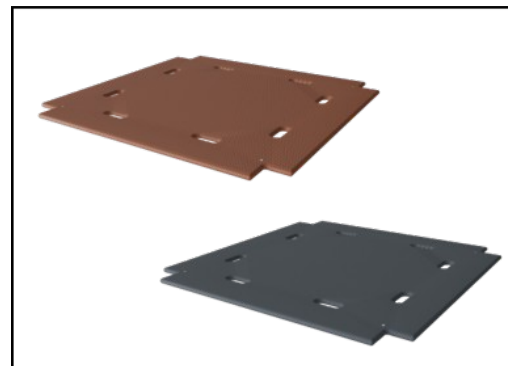

Floors and panel activities are available in two types of material: Waterproof plywood decks thickness 21.5mm from pine and alder wood with anti-slip film on both sides. High Pressure Laminate HPL thickness 17.8mm with slip resistant surface texture according to EN 438-6.

Item no. KPL101711-0902

Installation Information

Max. fall height	148 cm
Safety surfacing area	36.0 m ²
Total installation time	9.2
Excavation volume	1.17 m ³
Concrete volume	0.25 m ³
Footing depth (standard)	90 cm
Shipment weight	314 kg
Anchoring options	In-ground ✓ Surface ✓

Warranty Information

Aluminum	15 years
EcoCore HDPE	Lifetime
Hollow PE parts	10 years
Pinewood	10 years
Spare parts guaranteed	10 years

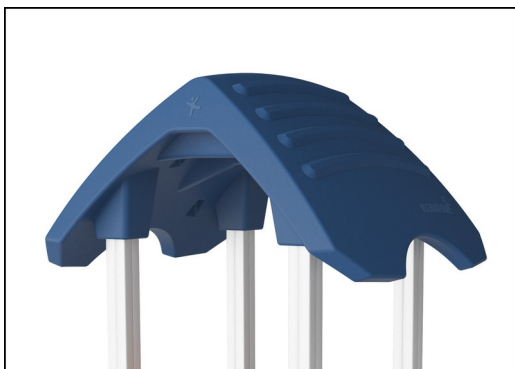

The large hollow components are made of 100% recyclable PE. The roof displayed is moulded in one piece with minimum 5,5mm wall thickness to ensure high durability in all climates around the world.

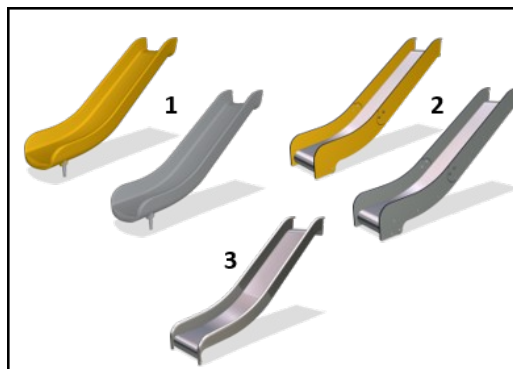

Slides are available in three different materials: moulded on piece PE slides made from 33% post-consumer materials, Combined EcoCore™ sides and stainless steel slide bed t=2mm. Full stainless steel AISI304 t=2mm.

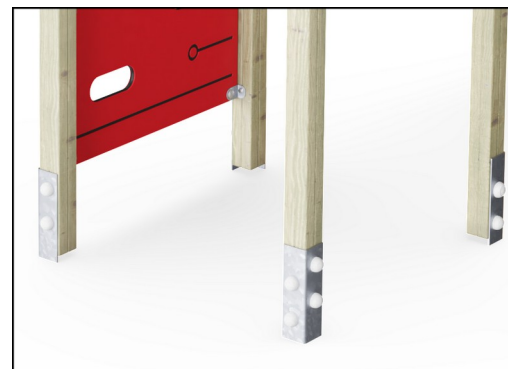

The main posts are equipped with hot dip galvanised steel footings. The steel footings elevates the posts 20mm from ground level to avoid contact with surfacing material.



Sustainability Data

KPL1017



Cradle to Gate A1-A3	Total CO ₂ emission	CO ₂ e/kg	Recycled materials
	kg CO ₂ e	kg CO ₂ e/kg	%
KPL101711-0902	439.98	1.67	41.46

The overall framework applied for these factors is the Environmental Product Declaration (EPD), which quantifies "environmental information on the life cycle of a product and enable comparisons between products fulfilling the same function" (ISO, 2006). This follows the structure and applies a Life-Cycle Assessment approach to the entire Product stage from raw material through manufacturing (A1-A3))

Kompan A/S
 C.F. Tietgens Boulevard 32C
 DK-5220 Odense SØ
 Denmark



Verification of CO₂ calculation of: Play systems



Data version no. 2023-10-05

The CO₂ calculation and data are in compliance with the principles of a carbon footprint impact according to the GHG protocol (Greenhouse Gas Protocol), Scope 3, cradle to gate related to all individual components in the product category: "Play systems" represented by item no.: PCM200321-0950.

(Scope 3 emissions include emission sources in the upstream and downstream value chain).

Date: 30. October 2023 | Valid until: 30. October 2025

Verified by:

Julie Marie Vejsgaard Larsen, LCA & EPD Consultant

Verification based on report: Validation of CO₂ calculation of 9 categories of Kompan product line, version 1.0, prepared by: Bureau Veritas HSE, Denmark: Julie M. V. Larsen.

Publication date: 30. October 2023

By Bureau Veritas HSE
 www.bureauveritas.dk
 +45 7731 1000



Play Tower with 2.5m Swing

KPL1017

* Max fall height | ** Total height | *** Safety surfacing area

* Max fall height | ** Total height

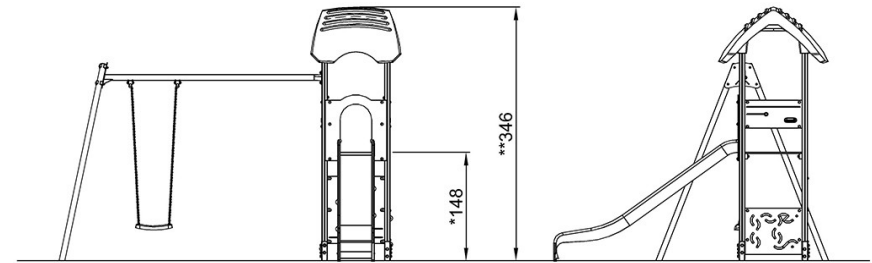
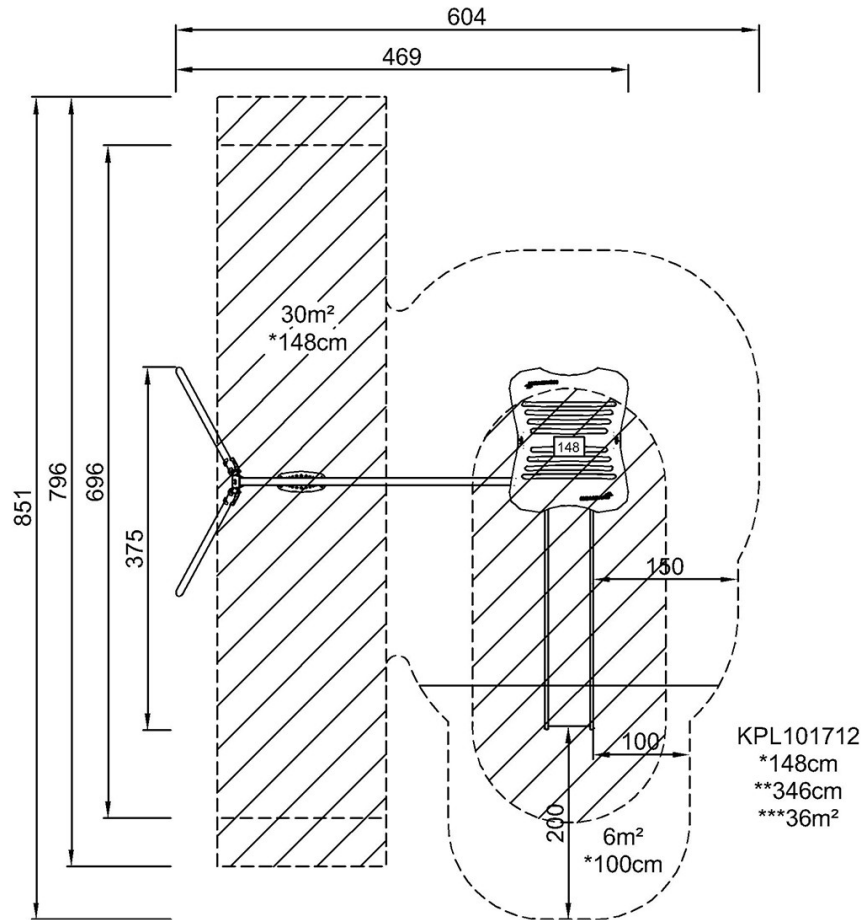

KPL101712

[Click to see TOP VIEW](#)

[Click to see SIDE VIEW](#)