

Double Tower with Fireman's Pole

KPL2013

KOMPAN
Let's play



Item no. KPL201311-0901	
General Product Information	
Dimensions LxWxH	326x383x307 cm
Age group	2+
Play capacity (users)	15
Colour options	● ●

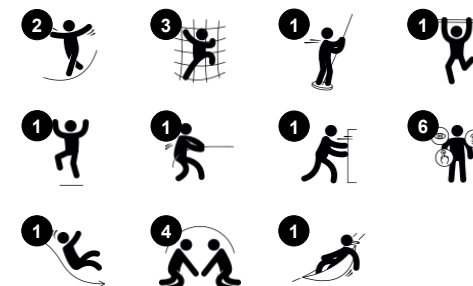

This classic play unit with the vibrant colours attracts children again and again. The tall climbing wall, the slide, the open net bridge and the tall climbing net all create a play variety that makes children want to come back again and again. The play activities, apart from being great fun, train the child's motor skills as well as muscles. When doing somersaults on the

somersault bar, the child trains its sense of space and balance, both mandatory when building up life skills such as judging distances. The see-through net bridge adds thrill, as the child can sense the height while passing. The big net has smaller as well as bigger meshes, facilitating climbing up and climbing through. The slide provides a fun exit, and the fireman's

pole provides a dare devil ride. All in all, it's play with a purpose. Enjoyment, fun and build-up of life skills, all in one.



Double Tower with Fireman's Pole

KPL2013



Somersault bar

Physical: develop balance and core when hanging from knees. Arm, leg and core muscles are developed when climbing up, somersaulting around. Balance and spatial awareness are strengthened. **Social-Emotional:** meeting, socializing and turn-taking when climbing up and down via bar.



Slide

Physical: sliding develops spatial awareness and a sense of balance. Furthermore, the core muscles are trained when sitting upright going down. **Social-Emotional:** empathy stimulated by turn-taking. **Cognitive:** young children develop their understanding of space, speed and distances when sliding down quickly.



Climbing net

Physical: children develop cross-body coordination and muscle strength when climbing. The big meshes allow for climbing and crawling through, supporting proprioception and spatial awareness. **Social-Emotional:** the big meshes allow for more children to sit together and talk.



Pipe ladder

Physical: cross coordination and eye-hand coordination are supported when children climb the ladder. The climbing also supports leg and arm muscles. **Social-Emotional:** learning about turn taking and cooperation.



Fireman's pole

Physical: coordination is supported when going down, as well as arm and core muscles. Landing strengthens bone density, which is built for life in early childhood. **Social-Emotional:** turn-taking and risk-taking. **Cognitive:** young children develop their understanding of space, speed and distances when gliding down fast.

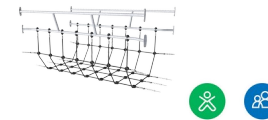

Net bridge

Physical: children develop their balance, cross coordination and spatial awareness in the open net. **Social-Emotional:** interaction with children outside, socializing. Cooperation and consideration, e.g. when passing others.



Rock climber

Physical: supports cross coordination and leg, arm and hand strength. **Social-Emotional:** the inclination makes climbing feel secure, especially for younger children.

Double Tower with Fireman's Pole

KPL2013



Panels of 19mm EcoCore™. EcoCore™ is a highly durable, eco friendly material, which is not only recyclable after use, but also consists of material produced from +95% recycled post consumer material from food packing waste.



The main tower posts are available in two types of material: European pine wood posts, pressure impregnated Class 3 with Tanalith E3475 according to EN335 (Equivalent to NTR Class AB). Aluminum post t=2mm with anodized surface treatment. Base material EN AW-6060 T66.



Floors and panel activities are available in two types of material: Waterproof plywood decks thickness 21.5mm from pine and alder wood with anti-slip film on both sides. High Pressure Laminate HPL thickness 17.8mm with slip resistant surface texture according to EN 438-6.



The large hollow components are made of 100% recyclable PE. The roof displayed is moulded in one piece with minimum 5,5mm wall thickness to ensure high durability in all climates around the world.

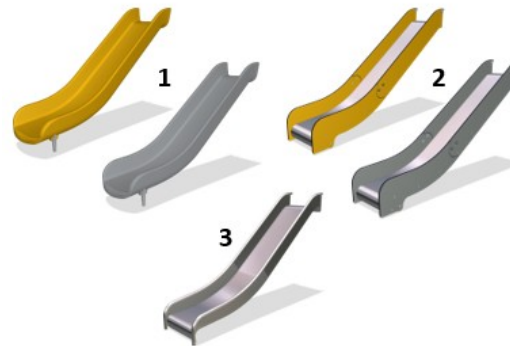

Slides are available in three different materials: moulded on piece PE slides made from 33% post-consumer materials, Combined EcoCore™ sides and stainless steel slide bed t=2mm. Full stainless steel AISI304 t=2mm.

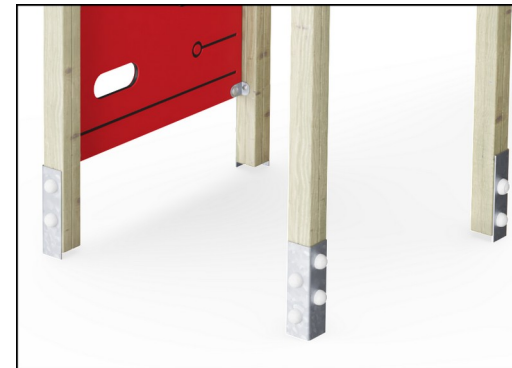

The main posts are equipped with hot dip galvanised steel footings. The steel footings elevates the posts 20mm from ground level to avoid contact with surfacing material.

Item no. KPL201311-0901

Installation Information

Max. fall height	118 cm
Safety surfacing area	32.7 m ²
Total installation time	14.7
Excavation volume	1.54 m ³
Concrete volume	0.00 m ³
Footing depth (standard)	90 cm
Shipment weight	395 kg
Anchoring options	In-ground ✓ Surface ✓

Warranty Information

Aluminum	15 years
EcoCore HDPE	Lifetime
Pinewood	10 years
Ropes & nets	10 years
Spare parts guaranteed	10 years



Sustainability Data

KPL2013



Cradle to Gate A1-A3	Total CO ₂ emission	CO ₂ e/kg	Recycled materials
	kg CO ₂ e	kg CO ₂ e/kg	%
KPL201311-0901	524.37	1.72	26.46

The overall framework applied for these factors is the Environmental Product Declaration (EPD), which quantifies "environmental information on the life cycle of a product and enable comparisons between products fulfilling the same function" (ISO, 2006). This follows the structure and applies a Life-Cycle Assessment approach to the entire Product stage from raw material through manufacturing (A1-A3))

Kompan A/S
 C.F. Tietgens Boulevard 32C
 DK-5220 Odense SØ
 Denmark



Verification of CO₂ calculation of: Play systems



Data version no. 2023-10-05

The CO₂ calculation and data are in compliance with the principles of a carbon footprint impact according to the GHG protocol (Greenhouse Gas Protocol), Scope 3, cradle to gate related to all individual components in the product category: "Play systems" represented by item no.: PCM200321-0950.

(Scope 3 emissions include emission sources in the upstream and downstream value chain).

Date: 30. October 2023 | Valid until: 30. October 2025

Verified by:

Julie Marie Vejsgaard Larsen, LCA & EPD Consultant

Verification based on report: Validation of CO₂ calculation of 9 categories of Kompan product line, version 1.0, prepared by: Bureau Veritas HSE, Denmark: Julie M. V. Larsen.

Publication date: 30. October 2023

By Bureau Veritas HSE
 www.bureauveritas.dk
 +45 7731 1000



Double Tower with Fireman's Pole

KPL2013

* Max fall height | ** Total height | *** Safety surfacing area

* Max fall height | ** Total height

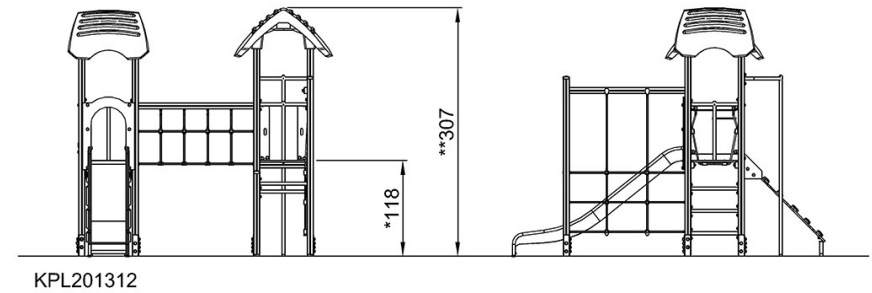
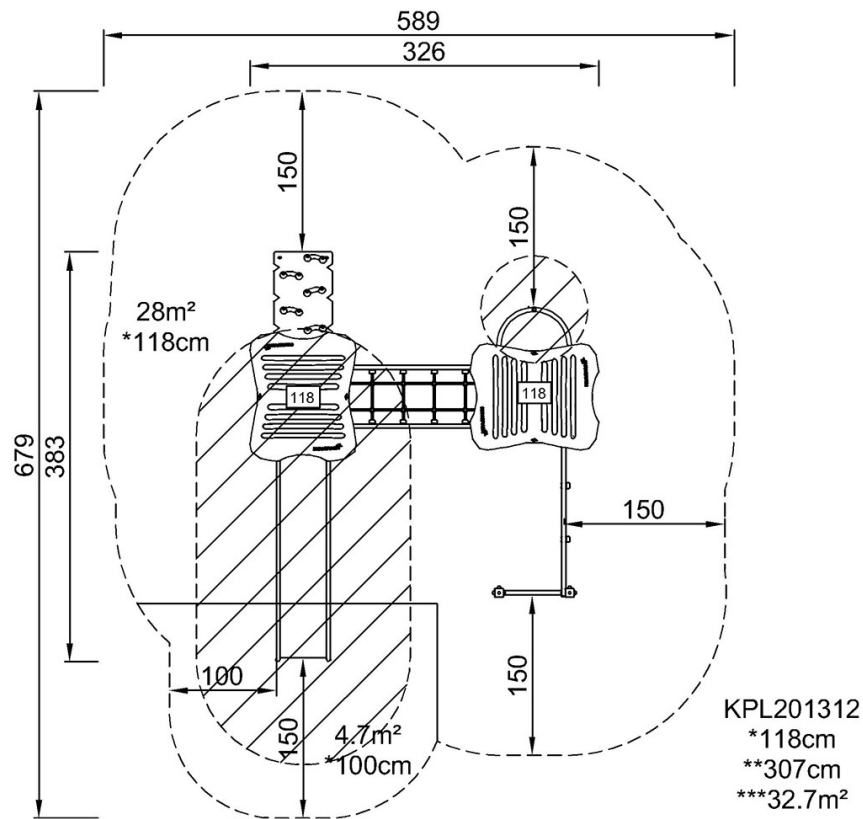

[Click to see TOP VIEW](#)

[Click to see SIDE VIEW](#)