

Track Ride Tower

PCM110321

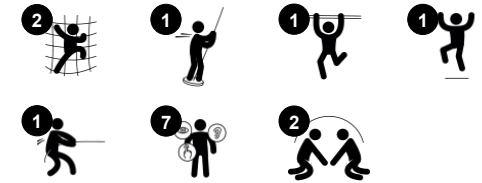

Item no. PCM110321-0906	
General Product Information	
Dimensions LxWxH	617x301x260 cm
Age group	6+
Play capacity (users)	4
Colour options	



The Track Ride Tower is a great play item that responds to the children's movement and urge for a thrill. This is the recipe for play success and will make children return for play again and again. The track ride glides down from the tower. Trained users will be able to flip their legs up to the top beam at the end and pushing themselves all the way back to the platform.

This trains muscles, proprioception and timing, all important abilities in sports and life. To other users, jumping off at the end or half back will train bone density. The handhold allow them to hand over the glider. The children train their arm, leg and core muscles. They greatly train their social-emotional skills, training turn-taking and empathy when helping others to succeed.

Thrilling, fun play that trains the school age child's social and physical life skills.

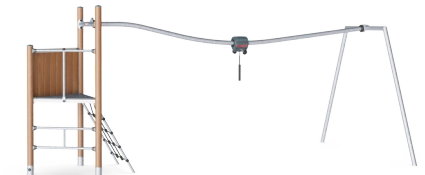

Track Ride Tower

PCM110321



Track Ride

Physical: train arm and core muscles. Bone density when jumping down from the handholds and motor skills like agility, balance and coordination are supported. **Social-Emotional:** cooperation, consideration, turn-taking, risk-taking, self-confidence.



Climbing net

Physical: supports physical strength and cross-body coordination, which impacts coordination of the right and left part of brain, fundamental for other skills such as the ability to read.



Pipe ladder

Physical: cross coordination and eye-hand coordination are supported when children climb the ladder. The climbing also supports leg and arm muscles. **Social-Emotional:** learning about turn taking and cooperation.

Track Ride Tower

PCM110321



All decks are supported by unique designed low-carbon aluminum profiles with multiple attachment options. The grey colored molded decks are made of 75% post-consumer waste PP material with a non-skid pattern and texture surface.



Panels of 19mm EcoCore™. EcoCore™ is a highly durable, eco friendly material, which is not only recyclable after use, but also consists of material produced from +95% recycled post consumer material from food packing waste.



Main posts with hot dip galvanized steel footing are available in different materials: Pressure impregnated pine wood posts. Pre-galvanized inside and outside with powder coated top finish steel posts. Lead free aluminum with color anodized top finish.

Item no. PCM110321-0906

Installation Information

Max. fall height	118 cm
Safety surfacing area	34.3 m ²
Total installation time	8.9
Excavation volume	0.30 m ³
Concrete volume	0.04 m ³
Footing depth (standard)	85 cm
Shipment weight	318 kg
Anchoring options	Surface ✓ In-ground ✓

Warranty Information

EcoCore HDPE	Lifetime
Hot dip galvanised steel	Lifetime
PP Decks	10 years
Ropes & nets	10 years
Spare parts guaranteed	10 years

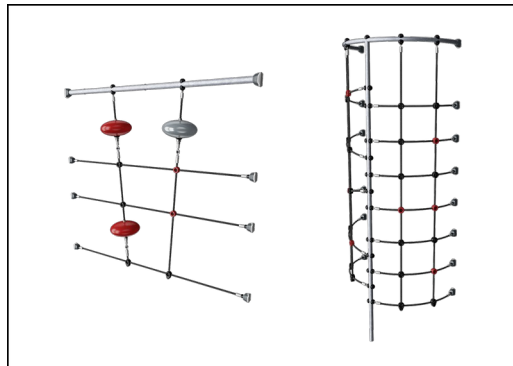

Ropes of UV-stabilized PES rope strands with inner steel cable reinforcement. The polyester yarn is made from +95% post-consumer materials and is inductively melted onto each strand.



The hang-on puller is designed with at welded steel core and covered with low-density PE housing. The two hot dip galvanised steel handles are angled to provide best possible ergonomic while gliding. The wheels of the puller are made of low noise TPU and installed with sealed ball bearings.



Wood version of FSC®-certified (FSC®C004450) pine wood with pressure impregnated base treatment and brown painted top finish. Vertical boards and top ends protected by a unique aluminum profile for high outdoor durability.



Sustainability Data

PCM110321

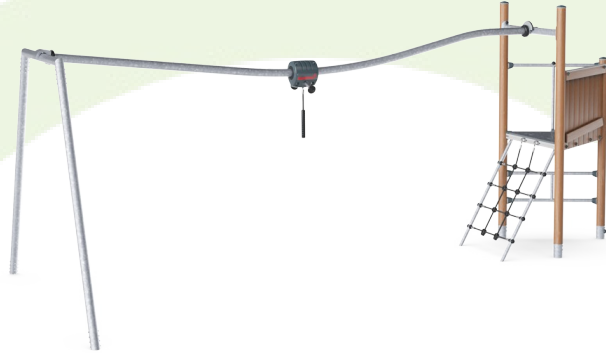

Cradle to Gate A1-A3	Total CO ₂ emission	CO ₂ e/kg	Recycled materials
	kg CO ₂ e	kg CO ₂ e/kg	%
PCM110321-0906	527.65	2.26	37.26

The overall framework applied for these factors is the Environmental Product Declaration (EPD), which quantifies "environmental information on the life cycle of a product and enable comparisons between products fulfilling the same function" (ISO, 2006). This follows the structure and applies a Life-Cycle Assessment approach to the entire Product stage from raw material through manufacturing (A1-A3))

Kompan A/S
 C.F. Tietgens Boulevard 32C
 DK-5220 Odense SØ
 Denmark



Verification of CO₂ calculation of: Play systems



Data version no. 2023-10-05

The CO₂ calculation and data are in compliance with the principles of a carbon footprint impact according to the GHG protocol (Greenhouse Gas Protocol), Scope 3, cradle to gate related to all individual components in the product category: "Play systems" represented by item no.: PCM200321-0950.

(Scope 3 emissions include emission sources in the upstream and downstream value chain).

Date: 30. October 2023 | Valid until: 30. October 2025

Verified by:

Julie Marie Vejsgaard Larsen, LCA & EPD Consultant

Verification based on report: Validation of CO₂ calculation of 9 categories of Kompan product line, version 1.0, prepared by: Bureau Veritas HSE, Denmark: Julie M. V. Larsen.

Publication date: 30. October 2023

By Bureau Veritas HSE
 www.bureauveritas.dk
 +45 7731 1000



Track Ride Tower

PCM110321

* Max fall height | ** Total height | *** Safety surfacing area

* Max fall height | ** Total height

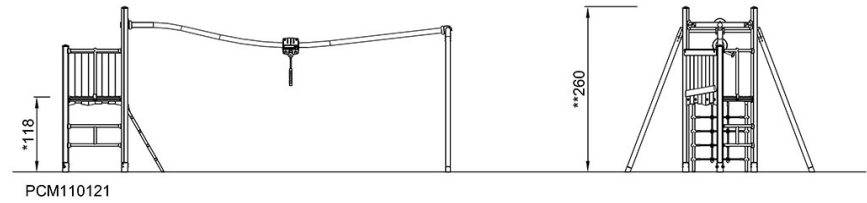
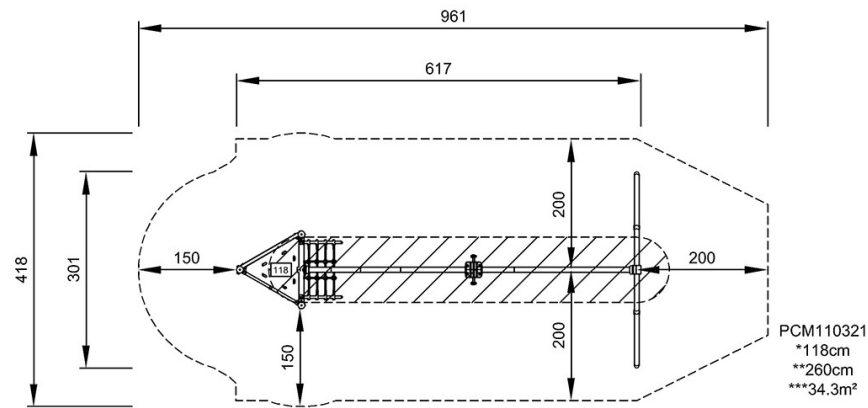

[Click to see TOP VIEW](#)

[Click to see SIDE VIEW](#)