

Observer

NAT526



With its multiple platforms and climbs, the Observer attracts world explorers among school age children. The variety of thrilling climbs and crawls via nets, steps, ladders, horizontal and tilted floors and climbing tubes stimulate children's balance and cross-coordination, and the proprioception: The variety of inclined, straight, swaying and firm

climbs provide fun challenges for all. It gives ways up and around the Observer for bigger and lesser dare devils. The motor skills trained are important for children's physical confidence and their security in moving, for instance in the street. The senses of balance and space are trained whizzing down the slide. The sense of balance is fundamental for all other physical

skills. The platforms and nets are nice meeting points for socializing with friends.

Item no. NAT526-0912	
General Product Information	
Dimensions LxWxH	467x439x267 cm
Age group	4+
Play capacity (users)	14
Colour options	

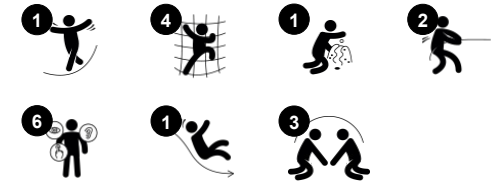

Observer

NAT526



Steering wheel

Cognitive: the manipulative steering wheel invites dramatic play which supports language and communication skills.



Slide

Physical: sliding develops spatial awareness and a sense of balance. Furthermore, the core muscles are trained when sitting upright going down. **Social-Emotional:** empathy stimulated by turn-taking.



Open stairs

Physical: stepping up the narrow stairway trains cross-coordination and spatial awareness, while developing leg muscles.



Teardrop handle

Physical: develop upper body muscles, when e.g. pulling yourself up or hanging in your arms.



Climbing net

Physical: children develop cross-body coordination and muscle strength. The asymmetry of the net challenges the children's climbing and crawling through. **Social-Emotional:** the big meshes allow for more children seated together, sharing.

Observer

NAT526

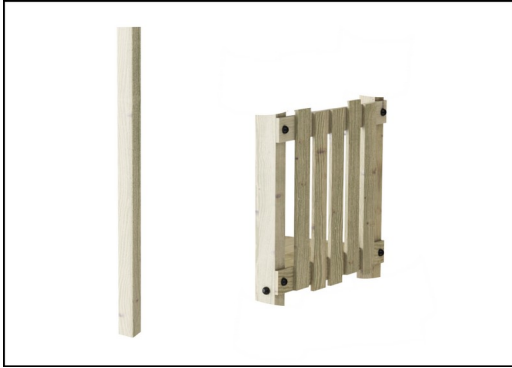

Posts and boards are made of pine wood from sustainable European sources. The wood is pressure impregnated Class 3 with Tanalith E3475 according to EN335 (Equivalent to NTR Class AB). On request it can be supplied as FSC® Certified (FSC® C004450).



Panels of 19mm EcoCore™. EcoCore™ is a highly durable, eco friendly material, which is not only recyclable after use, but also consists of material produced from +95% recycled post consumer material from food packing waste.

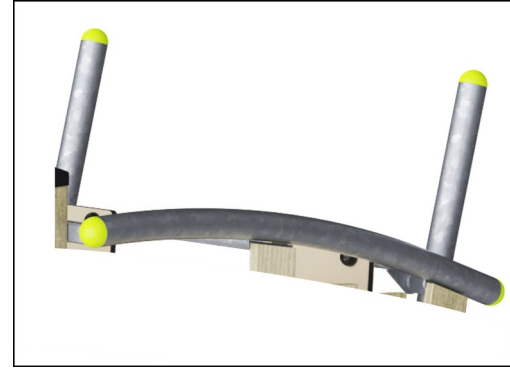

The steel surfaces are hot dip galvanized inside and outside with lead free zinc. The galvanization has excellent corrosion resistance in outside environments and requires low maintenance.



Corocord ropes of UV-stabilized PES rope strands with inner steel cable reinforcement. The polyester yarn is made from +95% post-consumer materials and is inductively melted onto each strand. PES has high strength with excellent resistance to abrasion and UV radiation. The rope loops are assembled by aluminum connectors.



The post end caps are made of injection molded high quality nylon (PA6). PA6 has good wearing and impact strength and is UV stabilized. The end caps protect vertical placed posts to ensure long lifetime.



The slide is made of combined EcoCore™ sides and stainless steel slide bed t=2mm.

Item no. NAT526-0912

Installation Information

Max. fall height	232 cm
Safety surfacing area	36.0 m ²
Total installation time	16.1
Excavation volume	1.36 m ³
Concrete volume	0.24 m ³
Footing depth (standard)	92 cm
Shipment weight	454 kg
Anchoring options	In-ground ✓ Surface ✓

Warranty Information

EcoCore HDPE	Lifetime
Hot dip galvanised steel	Lifetime
Pinewood	10 years
Ropes & nets	10 years
Spare parts guaranteed	10 years



Sustainability Data

NAT526



Cradle to Gate A1-A3	Total CO ₂ emission	CO ₂ e/kg	Recycled materials
	kg CO ₂ e	kg CO ₂ e/kg	%
NAT526-0912	641.10	1.67	38.41

The overall framework applied for these factors is the Environmental Product Declaration (EPD), which quantifies "environmental information on the life cycle of a product and enable comparisons between products fulfilling the same function" (ISO, 2006). This follows the structure and applies a Life-Cycle Assessment approach to the entire Product stage from raw material through manufacturing (A1-A3))

Kompan A/S
 C.F. Tietgens Boulevard 32C
 DK-5220 Odense SØ
 Denmark



Verification of CO₂ calculation of: Nature play



Data version no. 2023-10-05

The CO₂ calculation and data are in compliance with the principles of a carbon footprint impact according to the GHG protocol (Greenhouse Gas Protocol), Scope 3, cradle to gate related to all individual components in the product category: "Nature play" represented by item no.: NRO409-0621.

(Scope 3 emissions include emission sources in the upstream and downstream value chain).

Date: 30. October 2023 | Valid until: 30. October 2025

Verified by:

Julie Marie Vejsgaard Larsen, LCA & EPD Consultant

Verification based on report: Validation of CO₂ calculation of 9 categories of Kompan product line, version 1.0, prepared by: Bureau Veritas HSE, Denmark: Julie M. V. Larsen.

Publication date: 30. October 2023

By Bureau Veritas HSE
 www.bureauveritas.dk
 +45 7731 1000



Observer

NAT526

* Max fall height | ** Total height | *** Safety surfacing area

* Max fall height | ** Total height

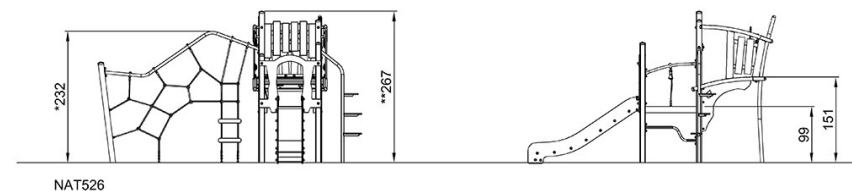
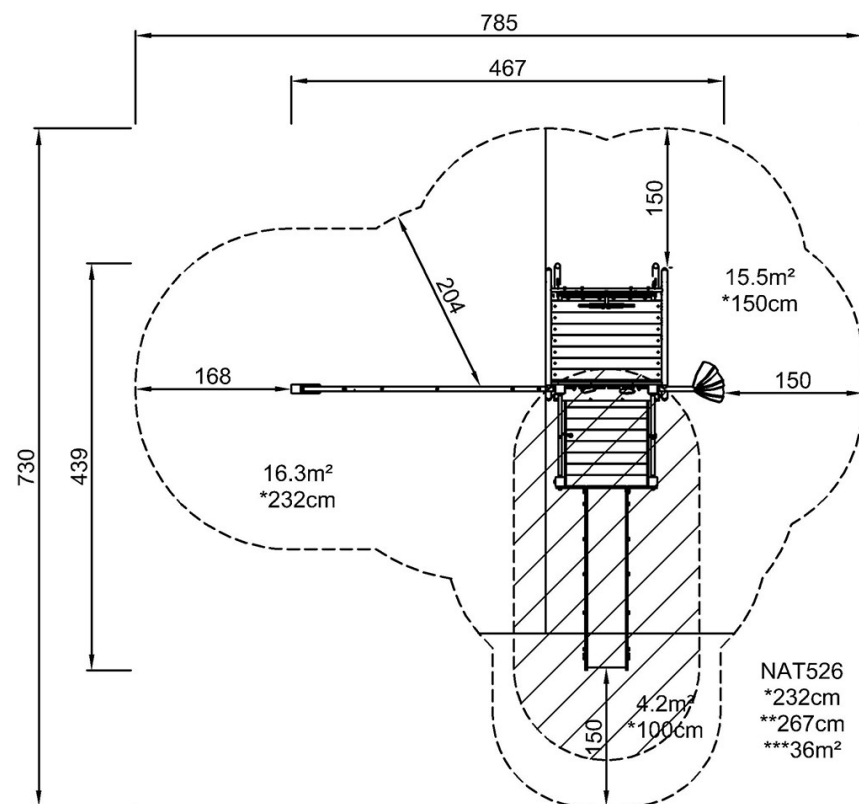

[Click to see TOP VIEW](#)

[Click to see SIDE VIEW](#)