

Crooked Den

NRC200101



Item no. NRC200101-1021	
General Product Information	
Dimensions LxWxH	556x385x345 cm
Age group	2+
Play capacity (users)	13
Colour options	



Amazing play choices await children in the Crooked Den and attract them to play repeatedly. A richly varied tactile and cognitive-creative play panel selection by a whimsical playhouse, which also invites social play. The wonderful play panels inspire logical thinking and creativity with their sewing and stapling activities and make children communicate and

cooperate. A fine balance, meet and slide section stimulates physically active play for the youngest: accessible platforms lead to the slide, allowing for carers to assist. Looping the access, the balance beam, and the slide trains children's balance and cross-coordination. These motor skills are fundamental for movement stability, and they benefit children's

physical and social-emotional development: training balance and gaining confidence from attempting and succeeding.



Crooked Den

NRC200101



Desk flaps w. holes

Physical: Hand-eye coordination is trained when moving the curtains to see through or pass things through the hole. **Social-Emotional:** cooperation, turn-taking and parallel play inspired by the two flaps. **Cognitive:** shifting things through holes supports logical thinking and the understanding of object permanence: that things still may exist when out of sight.



Slide

Physical: sliding develops spatial awareness and a sense of balance. Furthermore, the core muscles are trained when sitting upright going down. **Social-Emotional:** empathy stimulated by turn-taking. **Cognitive:** young children develop their understanding of space, speed and distances when sliding down quickly.



Window with curtains

Physical: Hand-eye coordination is trained when moving the curtains to see through or pass things through the hole. **Social-Emotional:** social interaction between the two sides of the panel supports turn-taking and cooperation skills. **Cognitive:** understanding of object permanence when playing games such as peek-a-boo. Dramatic play support, which encourages language skills. **Creative:** leaving a mark, deciding how to place curtains.



Stack and Turn Panel

Physical: Shifting the rubber spheres up and down the rope, across the 'lock' trains hand-eye coordination, important for motor control. **Social-Emotional:** Shifting the spheres and stacking them in cooperation supports negotiation and turn-taking. **Cognitive:** figuring out how to turn the rubber spheres to pass the 'lock' stimulates logical thinking skills and understanding of sequence. **Creative:** placing the ovals in new positions leaves a mark.



Sewing Panel

Physical: Hand-eye coordination is trained in fitting the string through the holes. This benefits children's motor skills e.g. when writing. **Social-Emotional:** Cooperating on fitting the string through the openings trains turn-taking, empathy and negotiation. **Cognitive:** Fitting the string through the holes supports logical thinking and rules understanding. **Creative:** the string length and various holes allow the children to make different patterns.



Balance beam

Physical: trains the sense of balance, fundamental for all other motor skills that makes it possible to navigate the world confidently and securely. **Social-Emotional:** turn-taking skills and negotiation when crossing each other on the beam. Room for a seated rest and exchange.



Handrail

Physical: develops children's upper body muscles and arm strength as well as cross coordination. This is especially important due to sedentary lifestyles.

Crooked Den

NRC200101



All Organic Robinia products by KOMPAN are made of Robinia wood from sustainable European sources. On request it can be supplied as FSC® Certified (FSC® C004450).



Transparent brown pigmented and colored parts, are coated with water-based paint and pigment that is environmentally friendly and with excellent UV resistance. The paint and pigment is in compliance with EN 71 Part 3.



The products are preassembled from the factory to ensure all safety requirements are considered. Please note that each Robinia fantasy structure will have its own unique appearance because of the natural shape of the individual wood posts.



There are Multiple footing options for all products: Surface anchoring with steel footings and expansion bolts. Wood in-ground or steel in-ground footings.

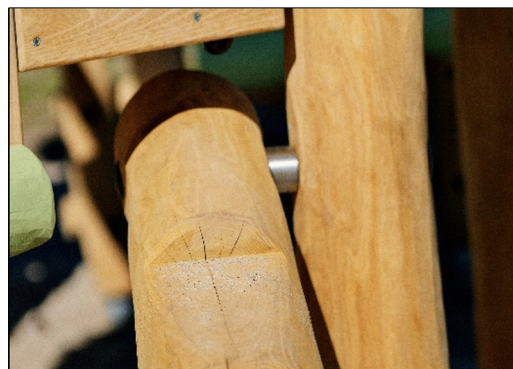

The hardware is made of stainless steel or galvanized steel to ensure durable connections with a high corrosion resistance.



The slides can be chosen in six different colors and three materials: Straight or curved one-piece molded PE slides, made from 33% recycled post-consumer materials in different colours. Combined EcoCore™ sides and stainless-steel. Full stainless steel in one piece design for more vandalism proof solutions.

Item no. NRC200101-1021

Installation Information

Max. fall height	100 cm
Safety surfacing area	48.9 m ²
Total installation time	28.0
Excavation volume	3.41 m ³
Concrete volume	2.30 m ³
Footing depth (standard)	100 cm
Shipment weight	1,563 kg
Anchoring options	In-ground ✓

Warranty Information

Corocord rope	10 years
EcoCore HDPE	Lifetime
Robinia wood	15 years
Spare parts guaranteed	10 years
Stainless steel components	Lifetime



Sustainability Data

NRC200101



Cradle to Gate A1-A3	Total CO ₂ emission	CO ₂ e/kg	Recycled materials
	kg CO ₂ e	kg CO ₂ e/kg	%
NRC200101-1021	309.09	0.23	2.29

The overall framework applied for these factors is the Environmental Product Declaration (EPD), which quantifies "environmental information on the life cycle of a product and enable comparisons between products fulfilling the same function" (ISO, 2006). This follows the structure and applies a Life-Cycle Assessment approach to the entire Product stage from raw material through manufacturing (A1-A3))

Kompan A/S
 C.F. Tietgens Boulevard 32C
 DK-5220 Odense SØ
 Denmark



Verification of CO₂ calculation of: Nature play



Data version no. 2023-10-05

The CO₂ calculation and data are in compliance with the principles of a carbon footprint impact according to the GHG protocol (Greenhouse Gas Protocol), Scope 3, cradle to gate related to all individual components in the product category: "Nature play" represented by item no.: NRO409-0621.

(Scope 3 emissions include emission sources in the upstream and downstream value chain).

Date: 30. October 2023 | Valid until: 30. October 2025

Verified by:

Julie Marie Vejsgaard Larsen, LCA & EPD Consultant

Verification based on report: Validation of CO₂ calculation of 9 categories of Kompan product line, version 1.0, prepared by: Bureau Veritas HSE, Denmark: Julie M. V. Larsen.

Publication date: 30. October 2023

By Bureau Veritas HSE
 www.bureauveritas.dk
 +45 7731 1000



Crooked Den

NRC200101

* Max fall height | ** Total height | *** Safety surfacing area

* Max fall height | ** Total height

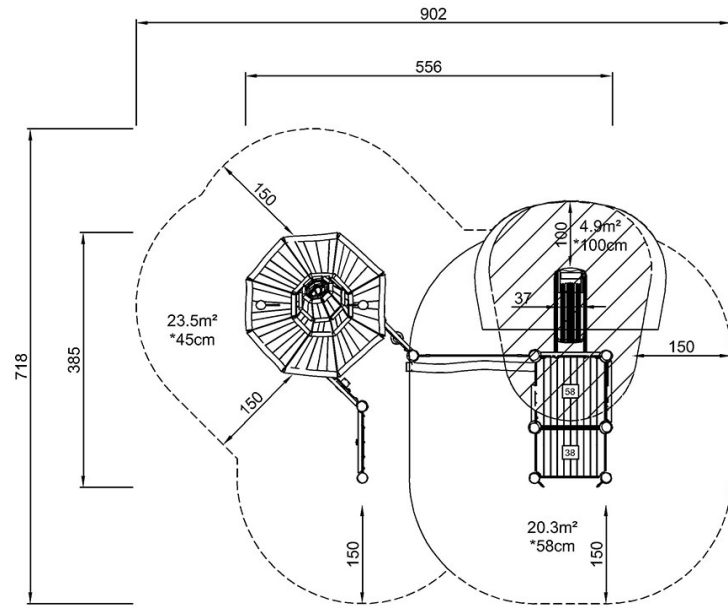

NRC200101
*100cm
**345cm
***48.9m²

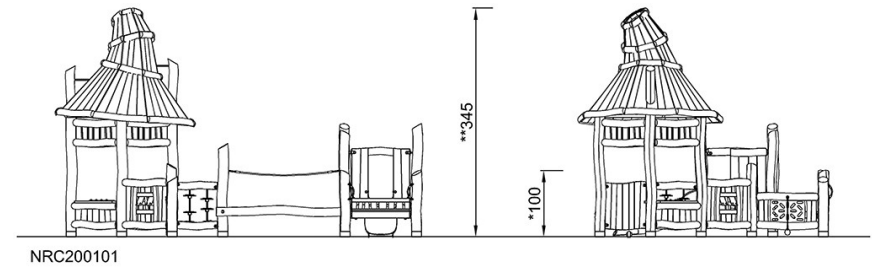

[Click to see TOP VIEW](#)

[Click to see SIDE VIEW](#)