

Four Tower with Tunnel

KPL4006

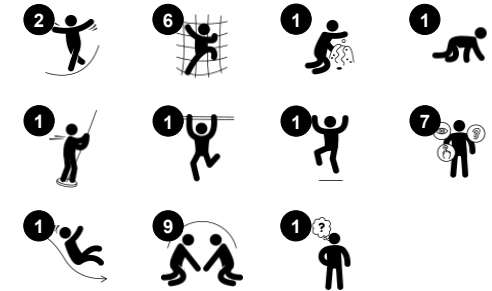

Item no. KPL400611-0901	
General Product Information	
Dimensions LxWxH	513x337x304 cm
Age group	2+
Play capacity (users)	24
Colour options	● ●



This four tower play structure offers varied creative play for a lot of children. The first tower can be reached via an inclined climbing wall with smiley steps, offering a supported climb up to a higher level. From here, a playful tunnel leads to the play net up to the next level. The fireman's pole gives a fast egress back to the ground. Alternatively, a bridge can be crossed

from where a classic slide can take the child to the ground or the child can pass the net with big meshes back to the start.



Four Tower with Tunnel

KPL4006



Net bridge, inclined

Physical: walking the open net up or downwards develops balance, spatial awareness and cross coordination. **Social-Emotional:** interaction with children outside, socializing. Cooperation and consideration, e.g. when passing others.



Fireman's pole

Physical: coordination is supported when going down, as well as arm and core muscles. Landing strengthens bone density, which is built for life in early childhood. **Social-Emotional:** turn-taking and risk-taking. **Cognitive:** young children develop their understanding of space, speed and distances when gliding down fast.



Tunnel

Physical: the children crawl through the tunnel, developing motor skills such as cross-body coordination and proprioception. **Social-Emotional:** turn-taking when passing each other.



Climbing net

Physical: children develop cross-body coordination and muscle strength when climbing. The big meshes allow for climbing and crawling through, supporting proprioception and spatial awareness. **Social-Emotional:** the big meshes allow for more children to sit together and talk.



Rock climber

Physical: supports cross coordination and leg, arm and hand strength. **Social-Emotional:** the inclination makes climbing feel secure, especially for younger children.



Slide

Physical: sliding develops spatial awareness and a sense of balance. Furthermore, the core muscles are trained when sitting upright going down. **Social-Emotional:** empathy stimulated by turn-taking. **Cognitive:** young children develop their understanding of space, speed and distances when sliding down quickly.



Ring game

Social-Emotional: cooperating from both sides on running rings up and down trains turn-taking and cooperation skills. **Cognitive:** figuring out how to turn the ring to make it fit the holes and move up or down trains logical skills. **Creative:** leaving rings in new positions leaves a mark in the playground.

Four Tower with Tunnel

KPL4006



Panels of 19mm EcoCore™. EcoCore™ is a highly durable, eco friendly material, which is not only recyclable after use, but also consists of material produced from +95% recycled post consumer material from food packing waste.



The main tower posts are available in two types of material: European pine wood posts, pressure impregnated Class 3 with Tanalith E3475 according to EN335 (Equivalent to NTR Class AB). Aluminum post t=2mm with anodized surface treatment. Base material EN AW-6060 T66.

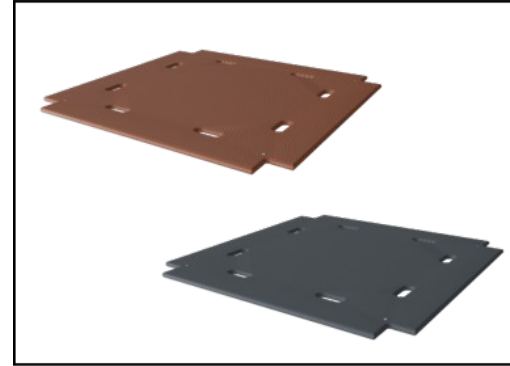

Floors and panel activities are available in two types of material: Waterproof plywood decks thickness 21.5mm from pine and alder wood with anti-slip film on both sides. High Pressure Laminate HPL thickness 17.8mm with slip resistant surface texture according to EN 438-6.

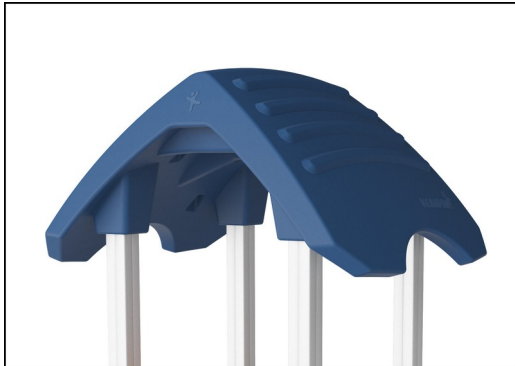

The large hollow components are made of 100% recyclable PE. The roof displayed is moulded in one piece with minimum 5,5mm wall thickness to ensure high durability in all climates around the world.

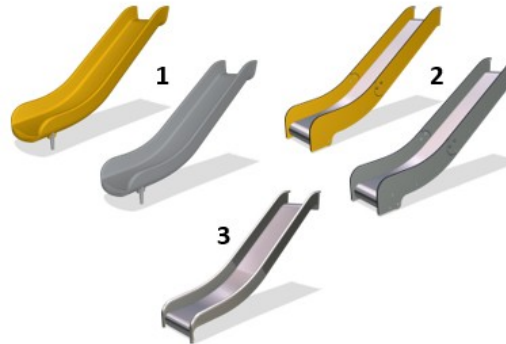

Slides are available in three different materials: moulded on piece PE slides made from 33% post-consumer materials, Combined EcoCore™ sides and stainless steel slide bed t=2mm. Full stainless steel AISI304 t=2mm.



Climbing nets are made of UV-stabilised PP rope with inner steel cable reinforcement. The rope is induction treated to obtain maximum fixation between steel and rope which provides excellent wear and tear resistance. All rope connectors are made of 100% recyclable PA material.

Item no. KPL400611-0901

Installation Information

Max. fall height	118 cm
Safety surfacing area	40.2 m ²
Total installation time	23.0
Excavation volume	2.22 m ³
Concrete volume	0.00 m ³
Footing depth (standard)	90 cm
Shipment weight	650 kg
Anchoring options	In-ground ✓ Surface ✓

Warranty Information

Aluminum	15 years
EcoCore HDPE	Lifetime
Pinewood	10 years
Ropes & nets	10 years
Spare parts guaranteed	10 years



Sustainability Data

KPL4006



Cradle to Gate A1-A3	Total CO ₂ emission	CO ₂ e/kg	Recycled materials
	kg CO ₂ e	kg CO ₂ e/kg	%
KPL400611-0901	748.34	1.51	32.91

The overall framework applied for these factors is the Environmental Product Declaration (EPD), which quantifies "environmental information on the life cycle of a product and enable comparisons between products fulfilling the same function" (ISO, 2006). This follows the structure and applies a Life-Cycle Assessment approach to the entire Product stage from raw material through manufacturing (A1-A3))

Kompan A/S
C.F. Tietgens Boulevard 32C
DK-5220 Odense SØ
Denmark



Verification of CO₂ calculation of: Play systems



Data version no. 2023-10-05

The CO₂ calculation and data are in compliance with the principles of a carbon footprint impact according to the GHG protocol (Greenhouse Gas Protocol), Scope 3, cradle to gate related to all individual components in the product category: "Play systems" represented by item no.: PCM200321-0950.

(Scope 3 emissions include emission sources in the upstream and downstream value chain).

Date: 30. October 2023 | Valid until: 30. October 2025

Verified by:

Julie Marie Vejsgaard Larsen, LCA & EPD Consultant

Verification based on report: Validation of CO₂ calculation of 9 categories of Kompan product line, version 1.0, prepared by: Bureau Veritas HSE, Denmark: Julie M. V. Larsen.

Publication date: 30. October 2023

By Bureau Veritas HSE
www.bureauveritas.dk
+45 7731 1000



Four Tower with Tunnel

KPL4006

* Max fall height | ** Total height | *** Safety surfacing area

* Max fall height | ** Total height

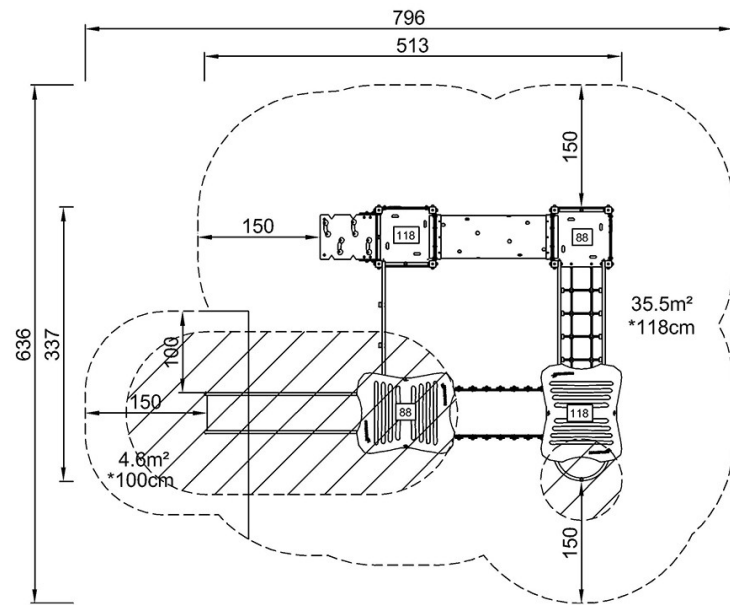

KPL400612
*118cm
**304cm
***40.2m²

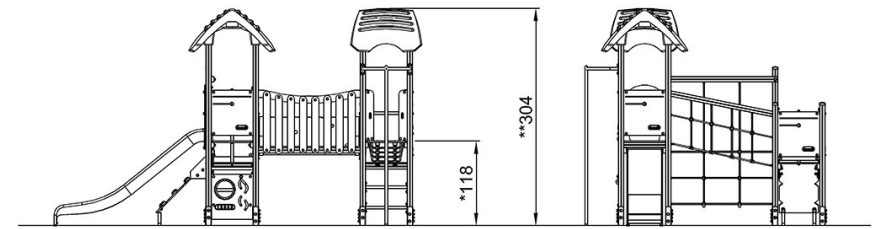

KPL400612

[Click to see TOP VIEW](#)

[Click to see SIDE VIEW](#)