

Anita Table

PAR1052



Item no. PAR1052-0611

General Product Information

Dimensions LxWxH	130x58x70 cm
Age group	
Play capacity (users)	
Colour options	<input type="radio"/> <input type="radio"/>



Outdoor Furniture plays an essential role in our communities by adding an inviting and social atmosphere, a place to meet, socialise or rest. Anita is classic and comfortable park furniture that invites citizens to take a seat and relax. They blend into and enhance public areas like parks and playgrounds etc. Anita Square Table is a freestanding table that can be combined

with Anita benches and chairs. Grouped furniture around a table offers countless possibilities for use.

Anita Table

PAR1052



Bench is made of pine wood from sustainable European sources. The wood is pressure impregnated Class 3 with Tanalith E.



Steel internal surfaces are hot-dip galvanised, and the outside surfaces are lead and zinc free. Galvanisation has excellent corrosion resistance within outdoor environments and requires very little maintenance. Painted steel parts are hot-dip galvanised and then powder coated.



Galvanisation is manufactured with a two-step process which includes light grinding and clean sweeping, which is then finished with a top powder coating to 70-120 µm thickness.

Item no. PAR1052-0611

Installation Information

Total installation time	0.6
Excavation volume	0.12 m ³
Concrete volume	0.09 m ³
Footing depth (standard)	65 cm
Shipment weight	26 kg
Anchoring options	Surface ✓ In-ground ✓

Warranty Information

Galvanised Steel	Lifetime
Painted Toplayer	10 years
Pinewood	10 years
Spare Parts Guarantee	10 years
Stainless Steel Components	Lifetime



KOMPAN outdoor furniture is available for surface and in-ground installation. Surface installation by anchoring to base layer or in-ground installation as either direct in ground or additional hot dip galvanised steel brackets.



The benches and tables can be combined in multiple settings by choosing individual products or assembled into larger solutions. See catalogue pages for more inspiration.

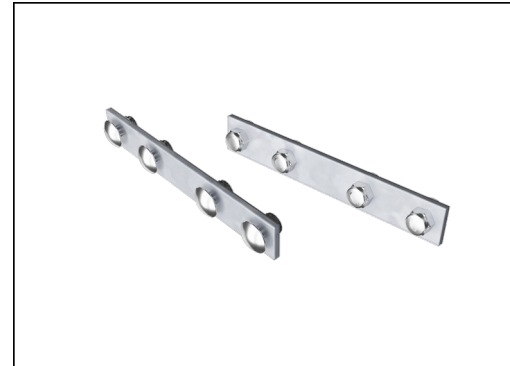

The hardware is made of stainless steel or galvanised steel to ensure durable connections with a high corrosion resistance.

Sustainability Data

PAR1052



Cradle to Gate A1-A3	Total CO ₂ emission	CO ₂ e/kg	Recycled materials
	kg CO ₂ e	kg CO ₂ e/kg	%
PAR1052-0611	37.81	1.70	31.64

The overall framework applied for these factors is the Environmental Product Declaration (EPD), which quantifies "environmental information on the life cycle of a product and enable comparisons between products fulfilling the same function" (ISO, 2006). This follows the structure and applies a Life-Cycle Assessment approach to the entire Product stage from raw material through manufacturing (A1-A3))

Kompan A/S
 C.F. Tietgens Boulevard 32C
 DK-5220 Odense SØ
 Denmark



Verification of CO₂ calculation of: Park



Data version no. 2023-10-05

The CO₂ calculation and data are in compliance with the principles of a carbon footprint impact according to the GHG protocol (Greenhouse Gas Protocol), Scope 3, cradle to gate related to all individual components in the product category: "Park" represented by item no.: PAR4070-0001.

(Scope 3 emissions include emission sources in the upstream and downstream value chain).

Date: 30. October 2023 | Valid until: 30. October 2025

Verified by:

Julie Marie Vejsgaard Larsen, LCA & EPD Consultant

Verification based on report: Validation of CO₂ calculation of 9 categories of Kompan product line, version 1.0, prepared by: Bureau Veritas HSE, Denmark: Julie M. V. Larsen.

Publication date: 30. October 2023

By Bureau Veritas HSE
 www.bureauveritas.dk
 +45 7731 1000

