

Saturn 2 Carousel

GXY957



Item no. GXY957000-3817

General Product Information

Dimensions LxWxH	316x41x253 cm
Age group	6+
Play capacity (users)	2
Color options	●

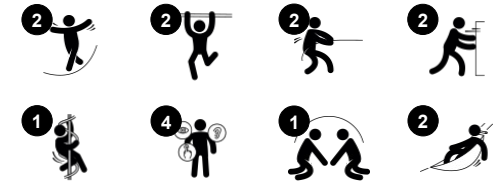

When playing on this large overhead rotating carousel with two sets of seats & handles, you need to use your strength and hold your balance! This seems to be the best way to describe the kind of play that takes place on the Saturn Carousel. This play equipment includes both physical skills like muscle and cardio whilst strengthening bone density when

you jump off and arm, leg and core muscles when helping friends to spin. It also supports social skills through cooperation and team work as well as providing a hang out place for chatting while gently spinning.

Saturn 2 Carousel

GXY957



Saturn ropes has six-stranded steel wires and a steel wire core. Each strand is tightly wrapped with PES yarn, which is melted onto each individual strand and made from +95% Post-consumer Materials. After initial friction has removed the surface fibres, a harder PES coating remains to protect each strand, making the ropes highly wear- and vandalism-resistant.



The special designed seat is made of a stainless-steel insert covered with a soft layer of PUR rubber. The seat is impact tested to fulfill all global playground standards and the rope has an ergonomic handhold of a 100cm long moulded on PUR rubber handle.



The two angled top handles are made of a moulded PP insert with an outer soft layer of TPV rubber. The handle is attached to the pipe with a galvanised steel inlay to ensure strength and durability.

Item no. GXY957000-3817

Installation Information

Max. fall height	150 cm
Safety surfacing area	69.4 m ²
Total installation time	3.0
Excavation volume	1.20 m ³
Concrete volume	0.80 m ³
Footing depth (standard)	120 cm
Shipment weight	183 kg
Anchoring options	In-ground ✓ Surface ✓



The steel surfaces are hot dip galvanized inside and outside with lead free zinc. The galvanisation has excellent corrosion resistance in outside environments and requires low maintenance.



Heavy duty engineered bearing system with single row deep groove ball bearings with rubber seals. The fully closed bearing construction is lifetime lubricated and maintenance free.



Sustainability Data

GXY957



Cradle to Gate A1-A3	Total CO ₂ emission	CO ₂ e/kg	Recycled materials
	kg CO ₂ e	kg CO ₂ e/kg	%
GXY957000-3817	428.20	2.73	47.00

The overall framework applied for these factors is the Environmental Product Declaration (EPD), which quantifies "environmental information on the life cycle of a product and enable comparisons between products fulfilling the same function" (ISO, 2006). This follows the structure and applies a Life-Cycle Assessment approach to the entire Product stage from raw material through manufacturing (A1-A3))

Kompan A/S
 C.F. Tietgens Boulevard 32C
 DK-5220 Odense SØ
 Denmark



Verification of CO₂ calculation of: Freestanding play equipment



Data version no. 2023-10-05

The CO₂ calculation and data are in compliance with the principles of a carbon footprint impact according to the GHG protocol (Greenhouse Gas Protocol), Scope 3, cradle to gate related to all individual components in the product category: "Freestanding play equipment" represented by item no.: GXY916012-3417.

(Scope 3 emissions include emission sources in the upstream and downstream value chain).

Date: 30. October 2023 | Valid until: 30. October 2025

Verified by:

Julie Marie Vejsgaard Larsen, LCA & EPD Consultant

Verification based on report: Validation of CO₂ calculation of 9 categories of Kompan product line, version 1.0, prepared by: Bureau Veritas HSE, Denmark: Julie M. V. Larsen.

Publication date: 30. October 2023

By Bureau Veritas HSE
 www.bureauveritas.dk
 +45 7731 1000



Saturn 2 Carousel

GXY957

* Max fall height | ** Total height | *** Safety surfacing area

* Max fall height | ** Total height

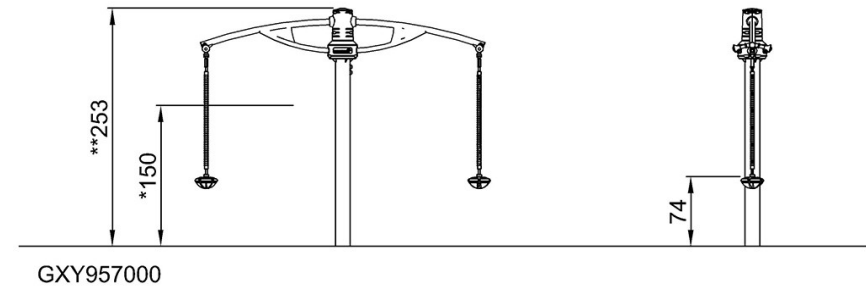
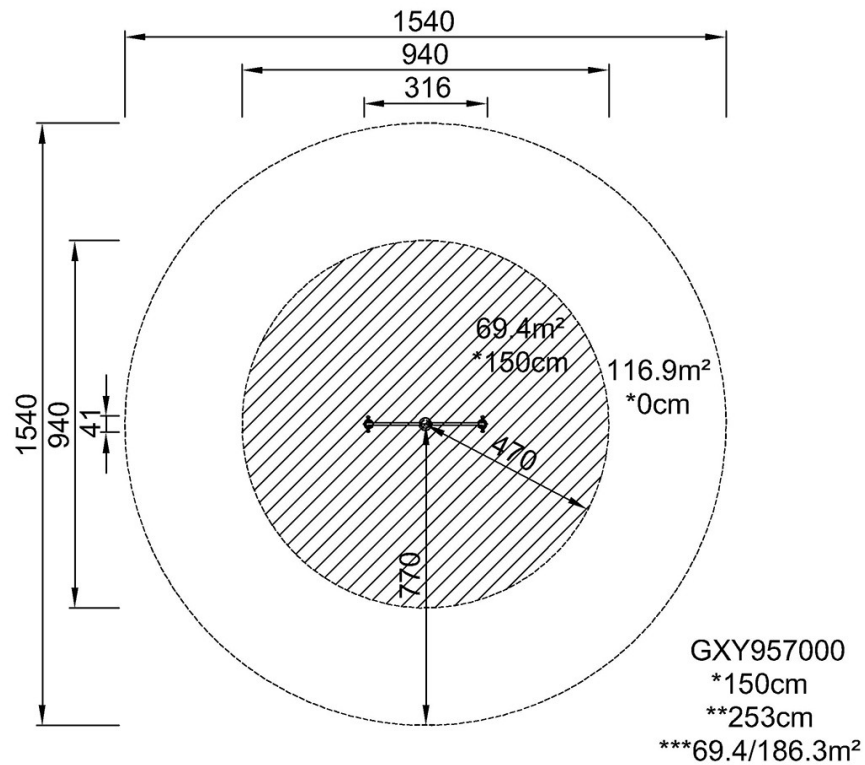

[Click to see TOP VIEW](#)

[Click to see SIDE VIEW](#)