

Ballentrechter

FRE3024



Item nummer FRE3024-3717	
Algemene Product Informatie	
Afmetingen LxBxH	102x102x305 cm
Leeftijdsgroep	3+
Speelcapaciteit	-
Kleuropties	



Gooi de bal in de ballentrechter en laat je verrassen uit welke opening hij komt. Een leuke uitdaging om de bal dan weer te kunnen vangen.



Ballentrechter

FRE3024



De stalen oppervlakken zijn van binnen en buiten thermisch verzinkt met loodvrij zink. Het verzinken heeft een uitstekende corrosiebestendigheid in de buitenlucht en vereist weinig onderhoud.

Item nummer FRE3024-3717

Installatie informatie

Max. valhoogte	0 cm
Veiligheidszone	12,7 m ²
Totale installatietijd	1,0
Graafwerk (vol.)	0,23 m ³
Benodigd beton	0,13 m ³
Verankeringsdiepte	91 cm
Verzendingsgewicht	59 kg
Verankeringsopties	In-ground ✓

Garantie informatie

HDG post	Levenslang
Solid plastic parts	10 jaar
Gegarandeerde reserveonderdelen	10 jaar



Sustainability Data

FRE3024



Cradle to Gate A1-A3	Total CO ₂ emission	CO ₂ e/kg	Recycled materials
	kg CO ₂ e	kg CO ₂ e/kg	%
FRE3024-3717	129,90	2,29	28,61

The overall framework applied for these factors is the Environmental Product Declaration (EPD), which quantifies "environmental information on the life cycle of a product and enable comparisons between products fulfilling the same function" (ISO, 2006). This follows the structure and applies a Life-Cycle Assessment approach to the entire Product stage from raw material through manufacturing (A1-A3))

Kompan A/S
 C.F. Tietgens Boulevard 32C
 DK-5220 Odense SØ
 Denmark

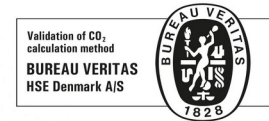

Verification of CO₂ calculation of: Sport



Data version no. 2023-10-05

The CO₂ calculation and data are in compliance with the principles of a carbon footprint impact according to the GHG protocol (Greenhouse Gas Protocol), Scope 3, cradle to gate related to all individual components in the product category: "Sport" represented by item no.: FRE600202-0901.

(Scope 3 emissions include emission sources in the upstream and downstream value chain).

Date: 30. October 2023 | Valid until: 30. October 2025

Verified by:

Julie Marie Vejsgaard Larsen, LCA & EPD Consultant

Verification based on report: Validation of CO₂ calculation of 9 categories of Kompan product line, version 1.0, prepared by: Bureau Veritas HSE, Denmark: Julie M. V. Larsen.

Publication date: 30. October 2023

By Bureau Veritas HSE
 www.bureauveritas.dk
 +45 7731 1000



Ballentrechter

FRE3024

Max. valhoogte | Totale Hoogte | Veiligheidszone

Max. valhoogte | Totale Hoogte

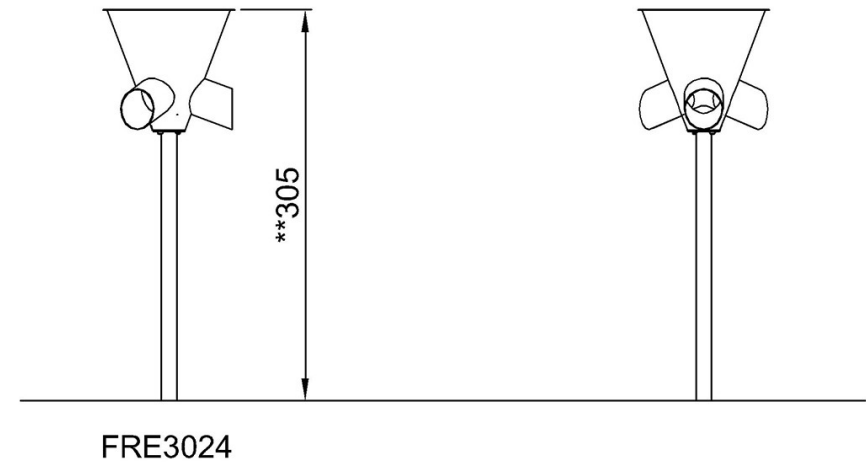
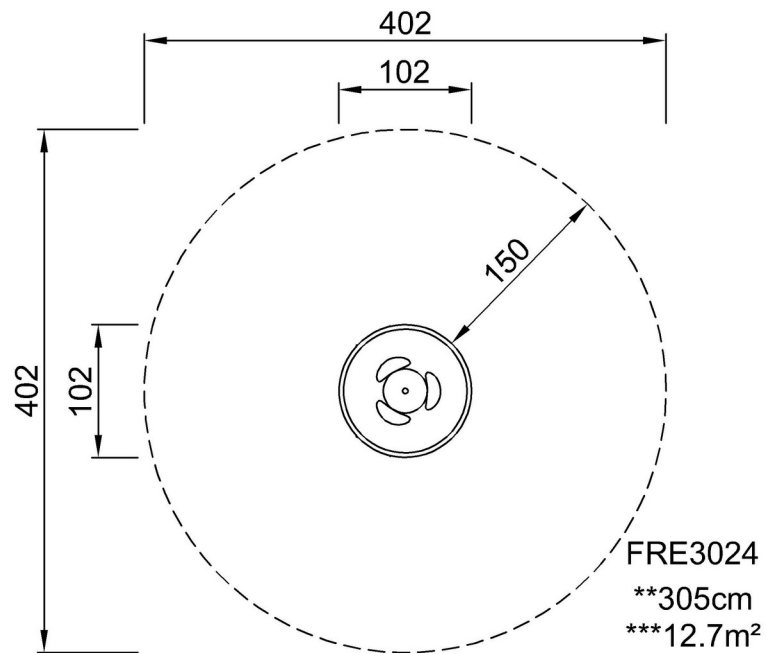

[Bekijk BOVENAANZICHT](#)

[Bekijk ZIJAANZICHT](#)