

Crazy Gander

M106



The amazing Crazy Gander should be in all playgrounds. Children seek it out to rock and play again and again. The Crazy Gander is truly universal design: the back, calf and foot supports, the shelter of the seat sides and the vertical handholds make it accessible and usable for all. Children rock the Crazy Gander using their leg, arm and core muscles to

coordinate movements and set it into motion. Alternatively, the spring will move when children stem their back into the seat, without using leg muscles. The hand-holds support a relevant grip height for all. Rocking the Crazy Gander supports the senses of balance and space, that are fundamental for body confidence and movement control. The spring's

response to movement builds an understanding of cause-and-effect. It supports logical thinking, a fundamental cognitive skill.



Item no. M10670-01P

General Product Information

Dimensions LxWxH	54x83x78 cm
Age group	2 - 5
Play capacity (users)	1
Colour options	



Crazy Gander

M106



Handhold

Physical: the vertical handgrips ensure a firm grip at different heights, necessary for rocking intensely. This trains hand and arm muscles.



Foot and back support

Physical: extra back and foot support for children with walking disabilities. Rocking promotes sense of balance and space, both important in navigating the body in space. Arms and leg muscles strengthened when holding tight and pushing with legs.



Theme

Cognitive: suggests a theme and supports dramatic play, which stimulates language and communication skills.



Rocking spring

Physical: response to movements adds to spatial awareness and sense of balance. These are fundamental motor skills that help the child's ability to sit still on a chair which takes a good sense of balance. **Cognitive:** trains the understanding of cause and effect: when I move my body, the spring responds with movement.

Crazy Gander

M106



Panels of 19mm EcoCore™. EcoCore™ is a highly durable, eco friendly material, which is not only recyclable after use, but also consists of material produced from +95% recycled post consumer material from food packing waste.



KOMPAN Springs are made of high quality spring steel according to EN10270. The springs are cleaned by phosphating before they are painted with an epoxy primer and a polyester powder coating as top finish. The springs are fixed by unique anti pinch fittings for maximum safety and long lifetime.



The springs are fixed by unique anti pinch fittings for maximum safety and long lifetime.

Item no. M10670-01P	
Installation Information	
Max. fall height	46 cm
Safety surfacing area	16.3 m ²
Total installation time	3.2
Excavation volume	0.19 m ³
Concrete volume	0.00 m ³
Footing depth (standard)	45 cm
Shipment weight	44 kg
Anchoring options	In-ground ✓ Surface ✓
Warranty Information	
EcoCore HDPE	Lifetime
Hot dip galvanised steel	Lifetime
Spare parts guaranteed	10 years
Springs	5 years

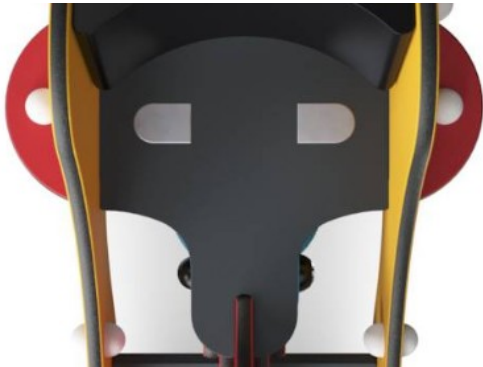

Seat is made of HPL with a thickness of 17.8mm with a very high wearing strength and a unique KOMPAN nonskid surface texture.



Rock wall handholds are made of pressure moulded high quality nylon (PA6). PA6 has good wearing and impact strength.



Back support is made of PUR. All components retain their properties in the temperature range of -30°C to 60°C. All materials are UV stabilised to a maximum without use of heavy metal stabilisers.

Elevated activities 0	Accessible elevated activities	Accessible ground level activities	Accessible ground level play types
Present	0	1	1
Required	0	1	1



Sustainability Data

M106



Cradle to Gate A1-A3	Total CO ₂ emission	CO ₂ e/kg	Recycled materials
	kg CO ₂ e	kg CO ₂ e/kg	%
M10670-01P	87.40	2.23	49.39

The overall framework applied for these factors is the Environmental Product Declaration (EPD), which quantifies "environmental information on the life cycle of a product and enable comparisons between products fulfilling the same function" (ISO, 2006). This follows the structure and applies a Life-Cycle Assessment approach to the entire Product stage from raw material through manufacturing (A1-A3))

Kompan A/S
C.F. Tietgens Boulevard 32C
DK-5220 Odense SØ
Denmark



Verification of CO₂ calculation of: Freestanding play equipment

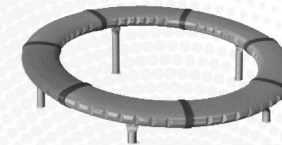

Data version no. 2023-10-05

The CO₂ calculation and data are in compliance with the principles of a carbon footprint impact according to the GHG protocol (Greenhouse Gas Protocol), Scope 3, cradle to gate related to all individual components in the product category: "Freestanding play equipment" represented by item no.: GXY916012-3417.

(Scope 3 emissions include emission sources in the upstream and downstream value chain).

Date: 30. October 2023 | Valid until: 30. October 2025

Verified by:

Julie Marie Vejsgaard Larsen, LCA & EPD Consultant

Verification based on report: Validation of CO₂ calculation of 9 categories of Kompan product line, version 1.0, prepared by: Bureau Veritas HSE, Denmark: Julie M. V. Larsen.

Publication date: 30. October 2023

By Bureau Veritas HSE
www.bureauveritas.dk
+45 7731 1000



Crazy Gander

M106

* Max fall height | ** Total height | *** Safety surfacing area

* Max fall height | ** Total height

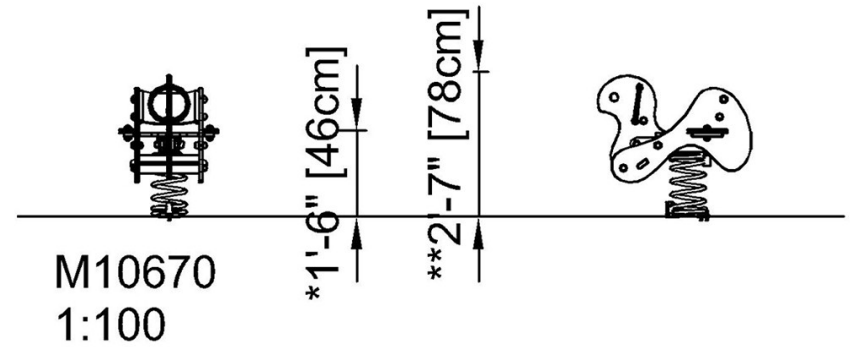
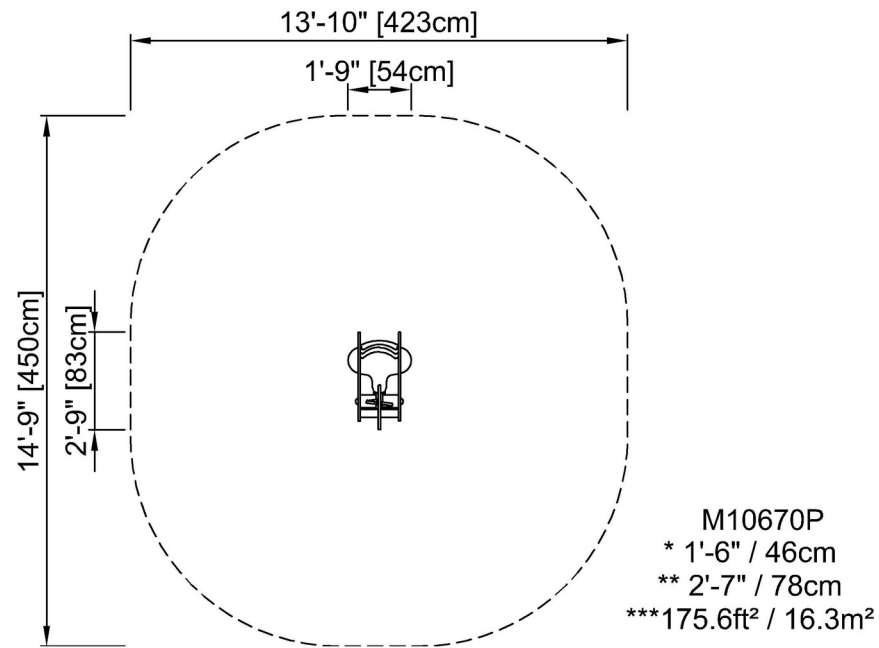

[Click to see TOP VIEW](#)

[Click to see SIDE VIEW](#)