

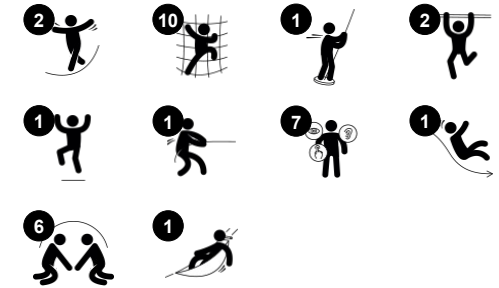

Item no. NAT520-0912	
General Product Information	
Dimensions LxWxH	305x818x545 cm
Age group	4+
Play capacity (users)	14
Colour options	



WOW! The awe-inspiring Amazon attracts school age children from far away with its fantastic variety of thrilling play activities. The 8 varied climbs and crawls via inclined nets, floors and climbing poles to the tall slide stimulate the children's agility, balance and cross-coordination. And the variety makes sure that there are different ways up for bigger and

lesser dare devils. The motor skills trained here are important for children's physical confidence and their security in moving, for instance in the street. Their sense of balance and space are trained when whizzing down the slide. The sense of balance is fundamental for all other physical skills. Under the platforms, vertical nets and hammocks provide nice resting points

for socializing with friends. The combination of wild activity and swaying net meetings will support children's friendships.



### Inclined platform

**Physical:** trains the sense of balance and space. **Social-Emotional:** courage, self-confidence, consideration and turn-taking, all important life skills, get practiced.



### Fireman's pole

**Physical:** coordination is supported when going down, as well as arm and core muscles. Landing strengthens bone density, which is built for life in early childhood. **Social-Emotional:** turn-taking and risk-taking.



### Climbing pole

**Physical:** develops children's cross coordination, eye-hand coordination and muscle strength when climbing up or down. **Social-Emotional:** turn-taking and self-regulation are trained, both important life skills.



### Hammock

**Physical:** coordination and sense of balance when swaying. **Social-Emotional:** meeting, pushing friends gently back and forth, turn-taking.



### Teardrop handle

**Physical:** develop upper body muscles, when e.g. pulling yourself up or hanging in your arms.



### Tube slide

**Physical:** sliding develops spatial awareness and a sense of balance. Furthermore, the core muscles are trained when sitting upright going down. **Social-Emotional:** thrill when going down fast. Empathy stimulated by turn-taking.

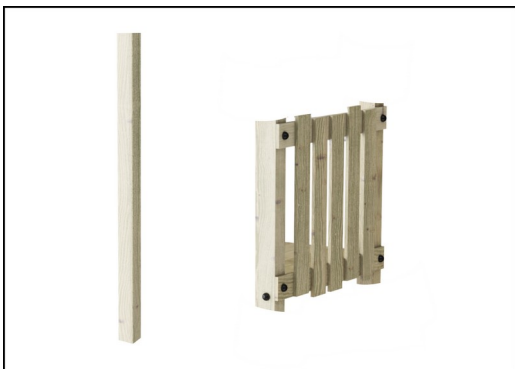

Posts and boards are made of pine wood from sustainable European sources. The wood is pressure impregnated Class 3 with Tanalith E3475 according to EN335 (Equivalent to NTR Class AB). On request it can be supplied as FSC® Certified (FSC® C004450).



Panels of 19mm EcoCore™. EcoCore™ is a highly durable, eco friendly material, which is not only recyclable after use, but also consists of material produced from +95% recycled post consumer material from food packing waste.



The steel surfaces are hot dip galvanized inside and outside with lead free zinc. The galvanization has excellent corrosion resistance in outside environments and requires low maintenance.



Corocord ropes of UV-stabilized PES rope strands with inner steel cable reinforcement. The polyester yarn is made from +95% post-consumer materials and is inductively melted onto each strand. PES has high strength with excellent resistance to abrasion and UV radiation. The rope loops are assembled by aluminum connectors.

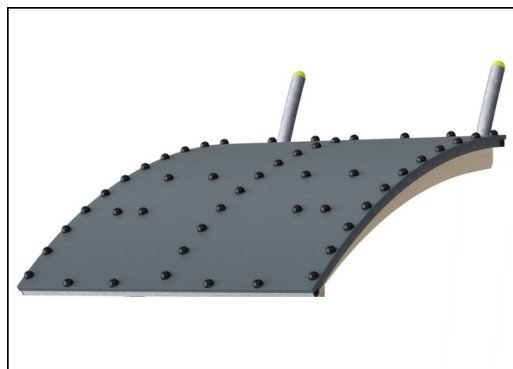

Roof is made of a steel frame supported Ekogrip® panel. The Ekogrip® panel consist of a 15mm thick PE base with 3 mm top-layer of rubber.



The slide is made of high quality stainless steel AISI 304. The steel is cleaned by a total pickling process after manufacturing to ensure a smooth and clean gliding surfaces.

Item no. NAT520-0912

### Installation Information

Max. fall height	287 cm
Safety surfacing area	50.0 m <sup>2</sup>
Total installation time	26.2
Excavation volume	2.66 m <sup>3</sup>
Concrete volume	0.10 m <sup>3</sup>
Footing depth (standard)	93 cm
Shipment weight	1,021 kg
Anchoring options	In-ground ✓ Surface ✓

### Warranty Information

EcoCore HDPE	Lifetime
Hot dip galvanised steel	Lifetime
Pinewood	10 years
Ropes & nets	10 years
Spare parts guaranteed	10 years



# Sustainability Data

NAT520



Cradle to Gate A1-A3	Total CO <sub>2</sub> emission	CO <sub>2</sub> e/kg	Recycled materials
	kg CO <sub>2</sub> e	kg CO <sub>2</sub> e/kg	%
<b>NAT520-0912</b>	2,113.65	2.46	35.13

The overall framework applied for these factors is the Environmental Product Declaration (EPD), which quantifies "environmental information on the life cycle of a product and enable comparisons between products fulfilling the same function" (ISO, 2006). This follows the structure and applies a Life-Cycle Assessment approach to the entire Product stage from raw material through manufacturing (A1-A3))

**Kompan A/S**  
 C.F. Tietgens Boulevard 32C  
 DK-5220 Odense SØ  
 Denmark



## Verification of CO<sub>2</sub> calculation of: Nature play



Data version no. 2023-10-05

The CO<sub>2</sub> calculation and data are in compliance with the principles of a carbon footprint impact according to the GHG protocol (Greenhouse Gas Protocol), Scope 3, cradle to gate related to all individual components in the product category: "Nature play" represented by item no.: NRO409-0621.

(Scope 3 emissions include emission sources in the upstream and downstream value chain).

**Date: 30. October 2023 | Valid until: 30. October 2025**

**Verified by:**

Julie Marie Vejsgaard Larsen, LCA & EPD Consultant

Verification based on report: Validation of CO<sub>2</sub> calculation of 9 categories of Kompan product line, version 1.0, prepared by: Bureau Veritas HSE, Denmark: Julie M. V. Larsen.

**Publication date: 30. October 2023**

**By Bureau Veritas HSE**  
 www.bureauveritas.dk  
 +45 7731 1000



\* Max fall height | \*\* Total height | \*\*\* Safety surfacing area

\* Max fall height | \*\* Total height

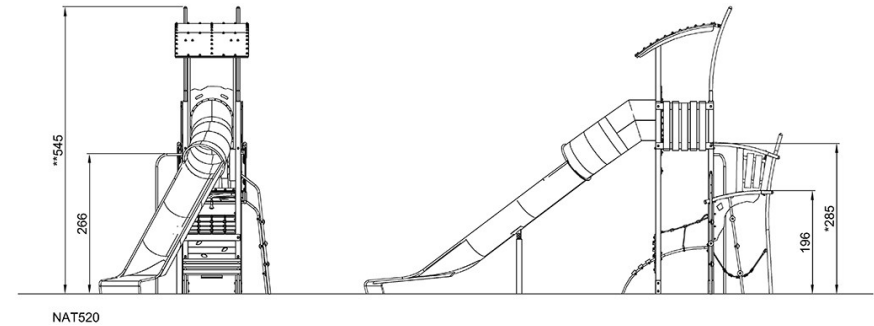
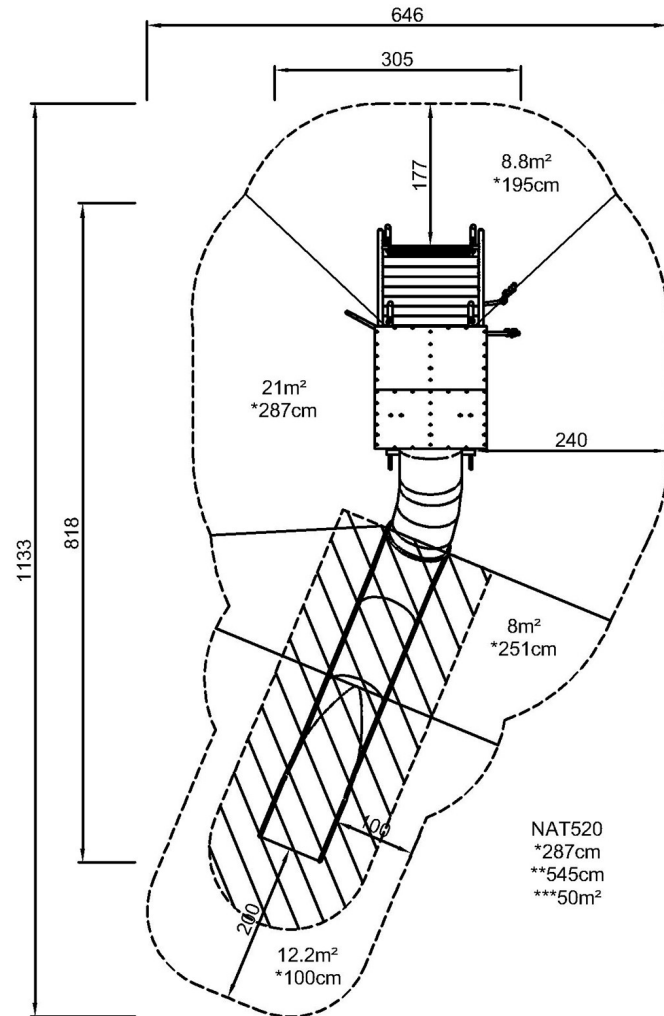

[Click to see TOP VIEW](#)

[Click to see SIDE VIEW](#)