

Tree House

NAT505

KOMPANI
Let's play



Item no. NAT505-0612

General Product Information

Dimensions LxWxH	158x322x215 cm
Age group	1+
Play capacity (users)	8
Colour options	

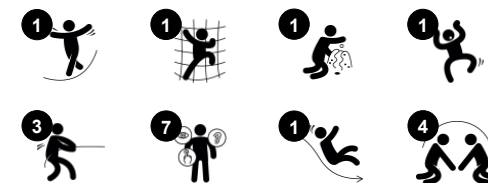

The Nature Range is made from beautiful pinewood. Timber play items are always a great addition to any playground, providing a rich and inviting new material for children to touch, feel and play with. The Tree House with its sturdy look-out tower, red slide, and cute climbing net attract children immediately: they want to loop the stair and slide, enter the house

and climb the net again and again. The versatile activities of the Tree House train a rich variety of motor and muscle skills in toddlers: they train their spatial awareness and cross-coordination when climbing or crawling onto the platform via the stairs of the net. This fundamental motor skill stimulates the centres in the brain that support reading skills. When

sliding from the Tree House, toddlers train their trunk stability and sense of balance. These are the basis of physical confidence in toddlers. The many tactile details, the red window, the binoculars, and the yellow sphere spur exploration and conversation with friends. The makes the Tree House a social attraction.



Tree House

NAT505



Binoculars

Cognitive: the binoculars promote dramatic play, a great trainer of language and communication skills. **Creative:** the binoculars can be moved around. Looking through them gives a new perspective on the world.



Slide

Physical: develops spatial awareness, sense of balance and trains core muscles when sitting upright going down. **Social-Emotional:** empathy stimulated by turn-taking. **Cognitive:** young children develop their understanding of space, speed and distances when sliding down.



Climbing net

Physical: children develop cross-body coordination and muscle strength. The asymmetry of the net challenges the children's climbing and crawling through. **Social-Emotional:** the big meshes allow for more children seated together, sharing.



Desk

Social-Emotional: great meeting place and space creator for storing or sitting.

Tree House

NAT505



Posts and boards are made of pine wood from sustainable European sources. The wood is pressure impregnated Class 3 with Tanalith E. On request it can be supplied as FSC® Certified (FSC® C004450).

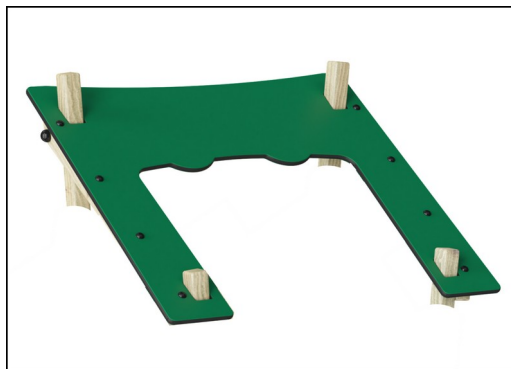

Panels of 19mm EcoCore™. EcoCore™ is a highly durable, eco-friendly material, which is not only recyclable after use but also consists of a core produced from 100% recycled material.

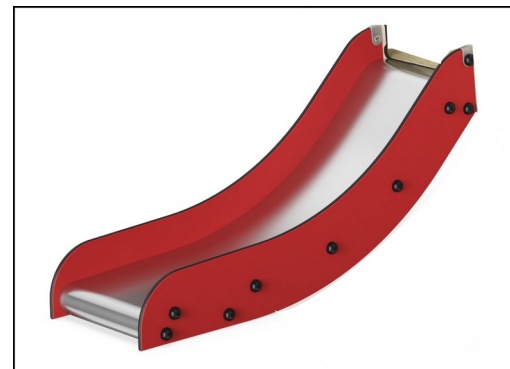

The slide is made of combined EcoCore™ sides and stainless steel slide bed t=2mm.

Item no. NAT505-0612	
Installation Information	
Max. fall height	100 cm
Safety surfacing area	21.1 m²
Total installation time	10.5
Excavation volume	0.67 m³
Concrete volume	0.00 m³
Footing depth (standard)	63 cm
Shipment weight	242 kg
Anchoring options	In-ground ✓ Surface ✓
Warranty Information	
Galvanised Steel	Lifetime
Pinewood	10 years
PUR Components	10 years
Ropes & Nets	10 years
Spare Parts Guarantee	10 years



Corocord ropes of UV-stabilized PES rope strands with inner steel cable reinforcement. The polyester yarn is made from +95% post-consumer materials and is inductively melted onto each strand. PES has high strength with excellent resistance to abrasion and UV radiation. The rope loops are assembled by aluminum connectors.



Binoculars are made of PUR, which is UV stabilised. All components retain their properties in the temperature range of -30°C to 60°C.



The steel surfaces are hot-dip galvanised inside and outside with lead-free zinc. The galvanisation has excellent corrosion resistance in outside environments and requires low maintenance.



Sustainability Data

NAT505



Cradle to Gate A1-A3	Total CO ₂ emission	CO ₂ e/kg	Recycled materials
	kg CO ₂ e	kg CO ₂ e/kg	%
NAT505-0612	240.60	1.28	40.07

The overall framework applied for these factors is the Environmental Product Declaration (EPD), which quantifies "environmental information on the life cycle of a product and enable comparisons between products fulfilling the same function" (ISO, 2006). This follows the structure and applies a Life-Cycle Assessment approach to the entire Product stage from raw material through manufacturing (A1-A3))

Kompan A/S
 C.F. Tietgens Boulevard 32C
 DK-5220 Odense SØ
 Denmark



Verification of CO₂ calculation of: Nature play



Data version no. 2023-10-05

The CO₂ calculation and data are in compliance with the principles of a carbon footprint impact according to the GHG protocol (Greenhouse Gas Protocol), Scope 3, cradle to gate related to all individual components in the product category: "Nature play" represented by item no.: NRO409-0621.

(Scope 3 emissions include emission sources in the upstream and downstream value chain).

Date: 30. October 2023 | Valid until: 30. October 2025

Verified by:

Julie Marie Vejsgaard Larsen, LCA & EPD Consultant

Verification based on report: Validation of CO₂ calculation of 9 categories of Kompan product line, version 1.0, prepared by: Bureau Veritas HSE, Denmark: Julie M. V. Larsen.

Publication date: 30. October 2023

By Bureau Veritas HSE
 www.bureauveritas.dk
 +45 7731 1000



Tree House

NAT505

* Max fall height | ** Total height | *** Safety surfacing area

* Max fall height | ** Total height

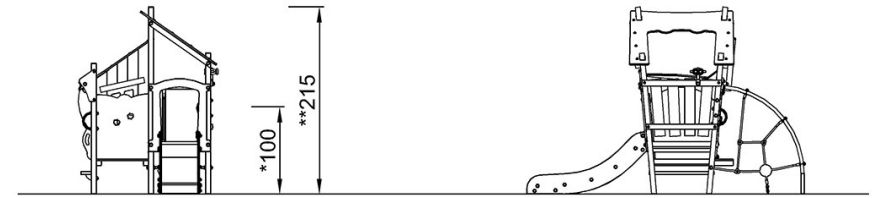
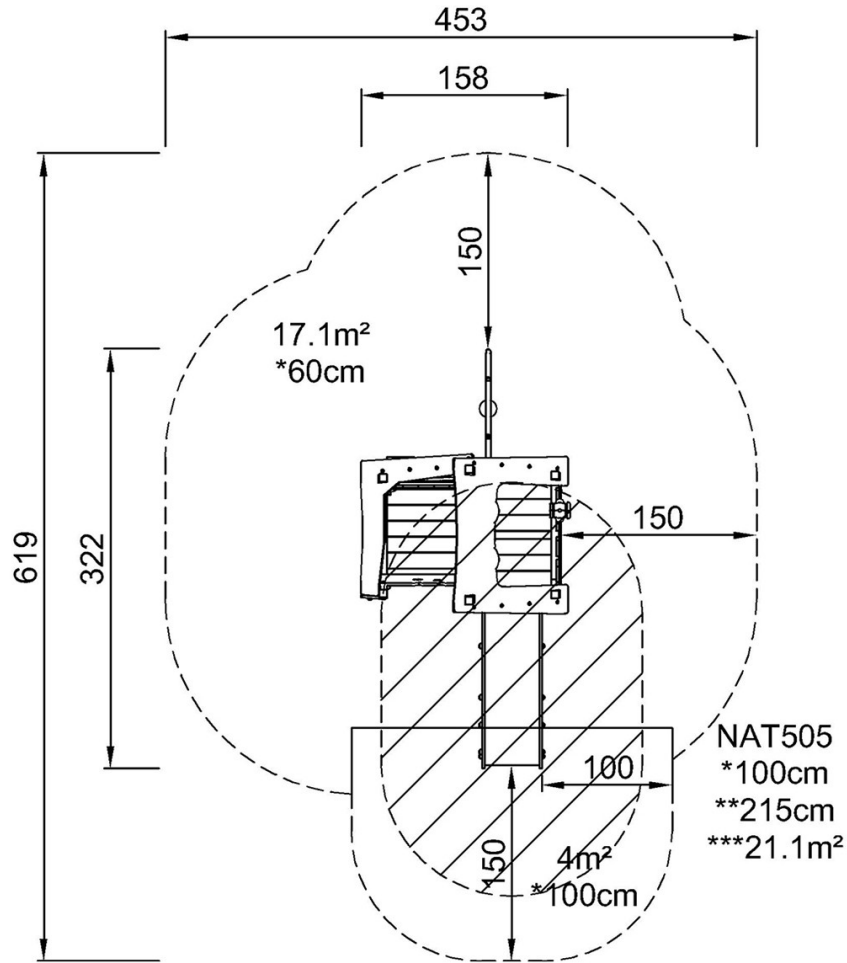

NAT505

[Click to see TOP VIEW](#)

[Click to see SIDE VIEW](#)