

Embankment Slide

PCM110121



Item no. PCM110121-0902	
General Product Information	
Dimensions LxWxH	463x161x110 cm
Age group	4 - 12
Play capacity (users)	3
Colour options	



The curved embankment slide motivates fun for all children and those childish at heart. Due to the embankment run loop, children will run up and slide down again and again. Sliding on the embankment slide is a great fun experience as friends can run up or down next to the sliding child. There is room for many children and for different ages and abilities to play together. The

embankment hill is a great place for rolling or running too. When children slide they train their core muscles, sitting upright while sliding down. This stimulates their trunk stability, important for avoiding back and neck pains – a growing problem in children due to sedentary lifestyles. Running uphill or downhill they can train their balance and coordination as well as their

muscle strength. They can train risk taking in holding back or letting go downhill.

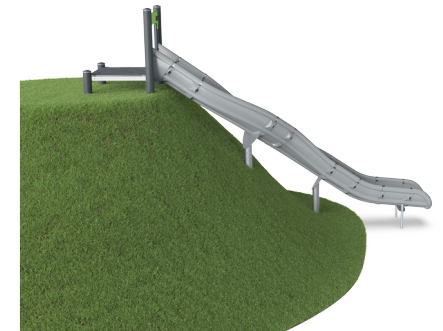

Embankment Slide

PCM110121



Curved slide

Physical: sliding develops spatial awareness and a sense of balance. Furthermore, the core muscles are trained when sitting upright going down. **Social-Emotional:** empathy stimulated by turn-taking.



Embankment Slide

PCM110121



The slides can be chosen in six different colors and three materials: Straight or curved one-piece molded PE slides, made from 33% recycled post-consumer materials in different colours. Combined EcoCore™ sides and stainless-steel. Full stainless steel in one piece design for more vandalism proof solutions.

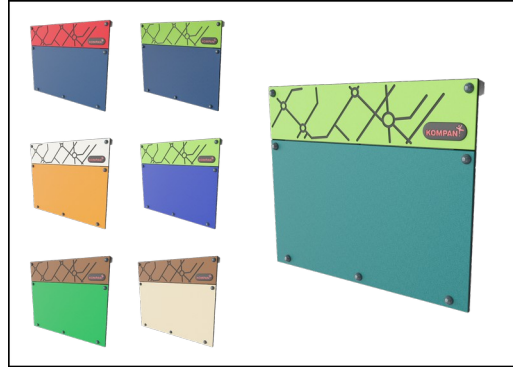

Panels of 19mm EcoCore™. EcoCore™ is a highly durable, eco friendly material, which is not only recyclable after use, but also consists of material produced from +95% recycled post consumer material from food packing waste.



Main posts with hot dip galvanized steel footing are available in different materials: Pressure impregnated pine wood posts. Pre-galvanized inside and outside with powder coated top finish steel posts. Lead free aluminum with color anodized top finish. Greenline TexMade posts of 95% post-consumer recycled PE and textile waste.



All decks are supported by unique designed low-carbon aluminum profiles with multiple attachment options. The grey colored molded decks are made of 75% post-consumer waste PP material with a non-skid pattern and texture surface.



KOMPAN GreenLine versions are designed with ultimate environmentally friendly materials with lowest possible CO2e emission factor. TexMade post, EcoCore™ panels of 95% post-consumer recycled waste and molded PP decks.

Item no. PCM110121-0902

Installation Information

Max. fall height	100 cm
Safety surfacing area	8.7 m ²
Total installation time	11.3
Excavation volume	0.27 m ³
Concrete volume	0.00 m ³
Footing depth (standard)	90 cm
Shipment weight	205 kg
Anchoring options	Surface <input checked="" type="checkbox"/> In-ground <input checked="" type="checkbox"/>

Warranty Information

EcoCore HDPE	Lifetime
PE slide	10 years
Post	10 years
PP Decks	10 years
Spare parts guaranteed	10 years

Elevated activities 0	Accessible elevated activities	Accessible ground level activities	Accessible ground level play types
Present	0	1	1
Required	0	1	1

**CSA
Z614**
compliant

Sustainability Data

PCM110121



Cradle to Gate A1-A3	Total CO ₂ emission	CO ₂ e/kg	Recycled materials
	kg CO ₂ e	kg CO ₂ e/kg	%
PCM110121-0951	344.08	2.14	49.40
PCM110121-0902	363.75	2.37	44.61

The overall framework applied for these factors is the Environmental Product Declaration (EPD), which quantifies "environmental information on the life cycle of a product and enable comparisons between products fulfilling the same function" (ISO, 2006). This follows the structure and applies a Life-Cycle Assessment approach to the entire Product stage from raw material through manufacturing (A1-A3))

Kompan A/S
 C.F. Tietgens Boulevard 32C
 DK-5220 Odense SØ
 Denmark



Verification of CO₂ calculation of: Play systems



Data version no. 2023-10-05

The CO₂ calculation and data are in compliance with the principles of a carbon footprint impact according to the GHG protocol (Greenhouse Gas Protocol), Scope 3, cradle to gate related to all individual components in the product category: "Play systems" represented by item no.: PCM200321-0950.

(Scope 3 emissions include emission sources in the upstream and downstream value chain).

Date: 30. October 2023 | Valid until: 30. October 2025

Verified by:

Julie Marie Vejsgaard Larsen, LCA & EPD Consultant

Verification based on report: Validation of CO₂ calculation of 9 categories of Kompan product line, version 1.0, prepared by: Bureau Veritas HSE, Denmark: Julie M. V. Larsen.

Publication date: 30. October 2023

By Bureau Veritas HSE
 www.bureauveritas.dk
 +45 7731 1000



Embankment Slide

PCM110121

* Max fall height | ** Total height | *** Safety surfacing area

* Max fall height | ** Total height

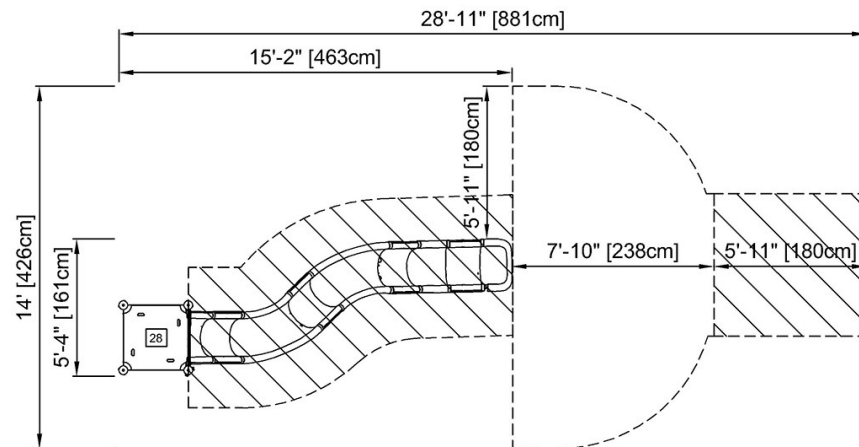

PCM110121
* 3'-3" / 100cm
** 3'-7" / 110cm
***94ft² / 8.7m²

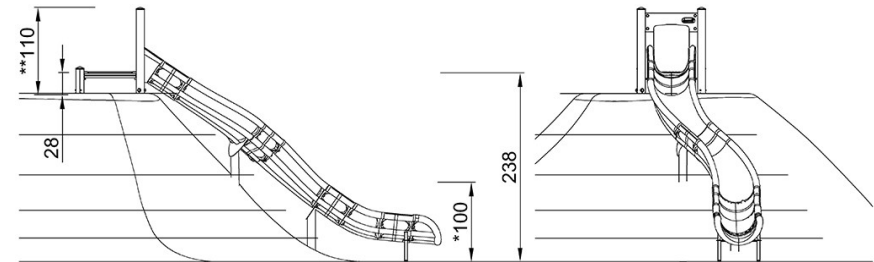

PCM110121

[Click to see TOP VIEW](#)

[Click to see SIDE VIEW](#)