

Miner

PCE50221

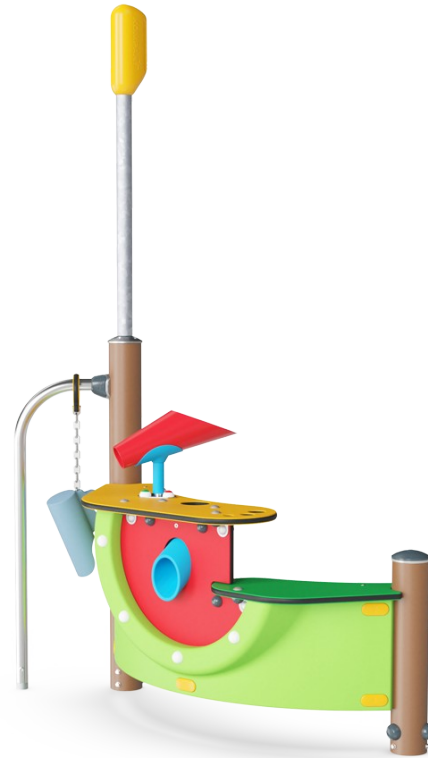

The Miner attracts children with its variety of colours. The number of sand play activities makes them come back again and again. The movable funnel can transport sand into the sieve or let it run through to the lower funnel. This stimulates the child's understanding of endurance and logical thinking. The scoop lifts sand from the ground and running it on the

tube helps build arm strength. The two table heights make cooperation possible for different ages: the youngest can use the lower table as a support for standing. Additionally, it creates a good space for working with materials. The two-sided Miner is a compact addition to any playground, providing room for children of all abilities to play together, from all sides.

Item no. PCE50221-0603

General Product Information

Dimensions LxWxH	140x50x210 cm
Age group	1+
Play capacity (users)	3
Colour options	  



Miner

PCE50221



Desk

Social-Emotional: fine meeting place and a space creator. Sharing and cooperation from both sides to create a social scenario that supports communication and cooperation.



Sand shovel

Physical: develops dexterity and upper body muscles. **Cognitive:** understanding of object permanence, emptying and filling scoop.



Funnel

Social-Emotional: trains cooperation and turn-taking as children put materials into the funnel. **Cognitive:** the passing of materials through funnels supports the children's logical thinking and for younger children the understanding of object permanence: that materials don't vanish but run through at the other end.



Changeable sand funnel

Social-Emotional: supports cooperation and turn-taking as children pour water or materials into the funnel. **Cognitive:** the passing of materials through funnels develops children's logical thinking, for younger children the understanding of object permanence: that materials do not vanish, but run through. **Creative:** the sand funnel can be turned, creating new directions of dispensing materials.

Miner

PCE50221



The Curved ELEMENTS panels are moulded of UV stabilised recyclable PE with multiple options for in-build play features that also ensures a strong panel solution. Straight panels are made of KOMPAN 19mm PE EcoCore™ which is a highly durable, eco-friendly and recyclable material.

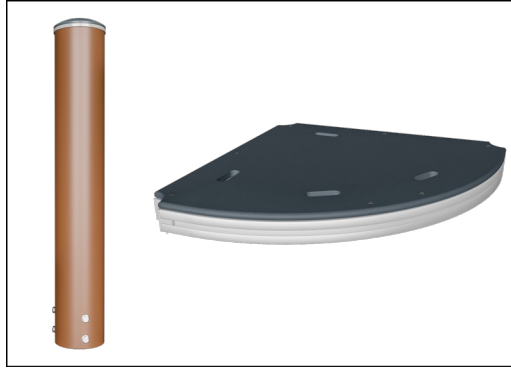

ELEMENTS decks are made of 17.8mm thick HPL supported by a uniquely designed aluminium frame with multiple attachment options by the usage of aluminium connectors. The main posts are made of high-quality pre-galvanised steel with a powder-coated top finish. Post tops are closed with caps of UV stabilised nylon (PA6).



ELEMENTS products are available in three different colour combinations: 1. classic blue, green2. blossom, orange, yellow3. nature lime, green

Item no. PCE50221-0603

Installation Information

Max. fall height	0 cm
Safety surfacing area	12.1 m ²
Total installation time	4.8
Excavation volume	0.06 m ³
Concrete volume	0.00 m ³
Footing depth (standard)	60 cm
Shipment weight	61 kg
Anchoring options	Surface ✓ In-ground ✓

Warranty Information

Curved Panels	10 years
EcoCore HDPE	Lifetime
Galvanised Steel	Lifetime
Post	10 years
Spare Parts Guarantee	10 years



Sustainability Data

PCE50221

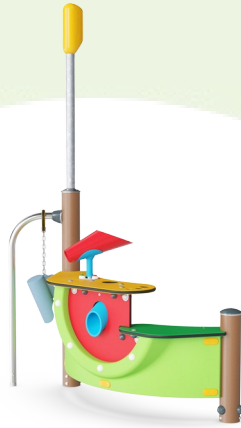

Cradle to Gate A1-A3	Total CO ₂ emission	CO ₂ e/kg	Recycled materials
	kg CO ₂ e	kg CO ₂ e/kg	%
PCE50221-0603	118.63	2.67	52.24

The overall framework applied for these factors is the Environmental Product Declaration (EPD), which quantifies "environmental information on the life cycle of a product and enable comparisons between products fulfilling the same function" (ISO, 2006). This follows the structure and applies a Life-Cycle Assessment approach to the entire Product stage from raw material through manufacturing (A1-A3))

Kompan A/S
 C.F. Tietgens Boulevard 32C
 DK-5220 Odense SØ
 Denmark



Verification of CO₂ calculation of: Play systems



Data version no. 2023-10-05

The CO₂ calculation and data are in compliance with the principles of a carbon footprint impact according to the GHG protocol (Greenhouse Gas Protocol), Scope 3, cradle to gate related to all individual components in the product category: "Play systems" represented by item no.: PCM200321-0950.

(Scope 3 emissions include emission sources in the upstream and downstream value chain).

Date: 30. October 2023 | Valid until: 30. October 2025

Verified by:

Julie Marie Vejsgaard Larsen, LCA & EPD Consultant

Verification based on report: Validation of CO₂ calculation of 9 categories of Kompan product line, version 1.0, prepared by: Bureau Veritas HSE, Denmark: Julie M. V. Larsen.

Publication date: 30. October 2023

By Bureau Veritas HSE
 www.bureauveritas.dk
 +45 7731 1000



Miner

PCE50221

* Max fall height | ** Total height | *** Safety surfacing area

* Max fall height | ** Total height

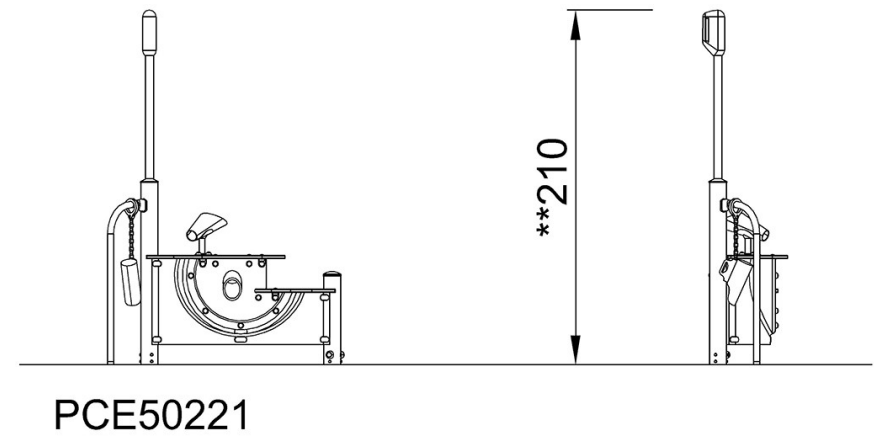
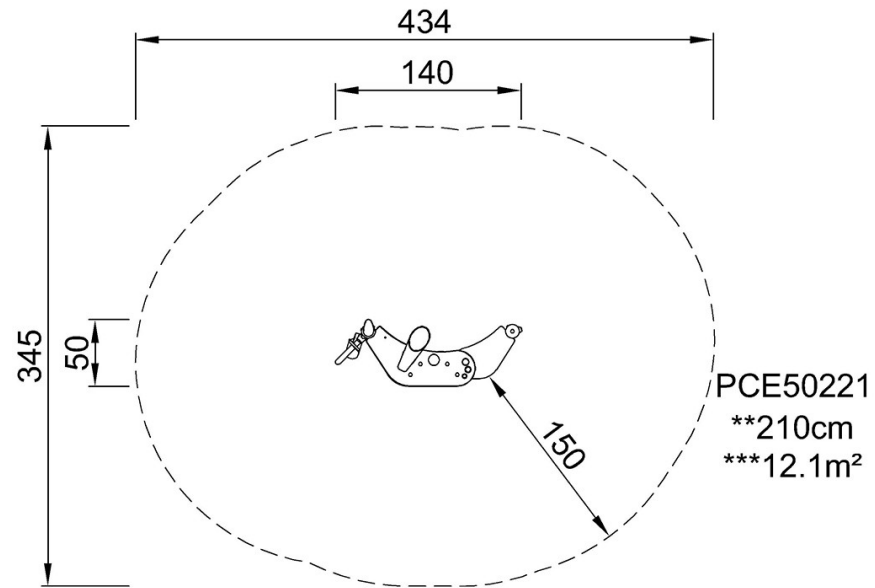

[Click to see TOP VIEW](#)

[Click to see SIDE VIEW](#)