

# Toddler Carousel

PCM154



Item no. PCM154-0901

## General Product Information

Dimensions LxWxH	7'6"x8'8"x7'9"
Age group	2 - 5
Play capacity (users)	3
Color options	  



The Toddler Carousel adds spinning to swinging, making for a thrilling experience for the toddlers. The shared experience made possible in the three seats make the children want to try the Toddler Carousel again and again. Apart from being pleasurable, the spinning and swinging movements train the sense of balance and space. These are crucial

motor skills, important for all other physical skills, and eventually concentration skills for learning. To babies, swinging trains their sense of space as well as their focal tracking. The seated position trains the core muscles. Socially, the three similar seats in parallel play trains thinking skills and the awareness of others from parallel play. The baby swing seat

has big holes to support access and egress for the child and the adult alike. The front grips are designed to prevent the seat from tilting. This adds to the feeling of security, providing even more joy in play.



# Toddler Carousel

PCM154



## Rotation

**Physical:** pushing or pulling into motion, children use their muscle strength and their cardio. The rotation develops the sense of balance and space when enjoying the ride.  
**Social-Emotional:** listening and negotiating how slow or fast to go, children develop empathy and cooperation skills.



## Toddler swing seat

**Physical:** balance, coordination and spatial awareness are developed when swinging. These are necessary skills for judging distances and navigating. **Social-Emotional:** feeling of security from support. **Cognitive:** understanding of cause and effect.



## Triple seating

**Social-Emotional:** stimulates parallel play and cooperation, important for social skills.

# Toddler Carousel

PCM154

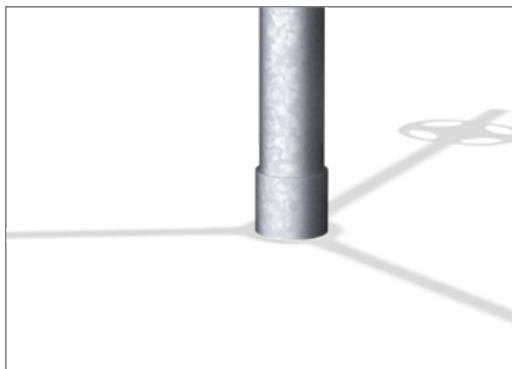

The carousel has different anchoring options for both surface and in-ground installation. All footings are hot dip galvanized inside and outside to ensure long lifetime of the product.



The seat hangers are made of high quality UV-stabilized nylon (PA6) housing with integrated lifetime sealed ball bearings. The chains are fixed by a stainless steel hook with theft proof snake-eye bolt in a turn able anti twist housing.



Center post is hot-dip galvanized in dimension Ø159 x 4 mm. Horizontal beams are hot-dip galvanized and powder coated in dimension Ø76,1 x 3,6 mm.



Chains are stainless steel and meet the requirements in ISO1434 -ISO1435 and DIN766.



The baby/toddler seat and suspension hinges are made of soft rubber (TPV). Polypropylene (PP) inside baby basket provides low friction leg openings for easy access (toddler in/out).



Belt seat is made of PUR. All components retain their properties in the temperature range of -30°C to 60°C. All materials are stabilized to a maximum without use of heavy metal stabilizers.

Item no. PCM154-0901

### Installation Information

Max. fall height	4'11"
Safety surfacing area	795ft <sup>2</sup>
Total installation time	3.8
Excavation volume	0.65yd <sup>3</sup>
Concrete volume	0.38yd <sup>3</sup>
Footing depth (standard)	3'3"
Shipment weight	487lbs
Anchoring options	In-ground ✓ Surface ✓

### Warranty Information

Chains	10 Years
Hot dip galvanized steel	Lifetime
Spare Parts Availability	10 Years
Swing hangers	5 Years
Swing seat	10 Years

Elevated activities 0	Accessible elevated activities	Accessible ground level activities	Accessible ground level play types
Present	0	1	1
Required	0	1	1



# Sustainability Data

PCM154



Cradle to Gate A1-A3	Total CO <sub>2</sub> emission	CO <sub>2</sub> e/kg	Recycled materials
	kg CO <sub>2</sub> e	kg CO <sub>2</sub> e/kg	%
<b>PCM154-0901</b>	461.26	3.21	43.24

The overall framework applied for these factors is the Environmental Product Declaration (EPD), which quantifies "environmental information on the life cycle of a product and enable comparisons between products fulfilling the same function" (ISO, 2006). This follows the structure and applies a Life-Cycle Assessment approach to the entire Product stage from raw material through manufacturing (A1-A3))

**Kompan A/S**  
C.F. Tietgens Boulevard 32C  
DK-5220 Odense SØ  
Denmark



## Verification of CO<sub>2</sub> calculation of: Themed play systems



Data version no. 2023-10-05

The CO<sub>2</sub> calculation and data are in compliance with the principles of a carbon footprint impact according to the GHG protocol (Greenhouse Gas Protocol), Scope 3, cradle to gate related to all individual components in the product category: "Themed play systems" represented by item no.: MSC641100-3717P.

(Scope 3 emissions include emission sources in the upstream and downstream value chain).

**Date: 30. October 2023 | Valid until: 30. October 2025**

Verified by:

Julie Marie Vejsgaard Larsen, LCA & EPD Consultant

Verification based on report: Validation of CO<sub>2</sub> calculation of 9 categories of Kompan product line, version 1.0, prepared by: Bureau Veritas HSE, Denmark: Julie M. V. Larsen.

**Publication date: 30. October 2023**

By Bureau Veritas HSE  
www.bureauveritas.dk  
+45 7731 1000



# Toddler Carousel

PCM154

\* Max fall height | \*\* Total height | \*\*\* Safety surfacing area

\* Max fall height | \*\* Total height

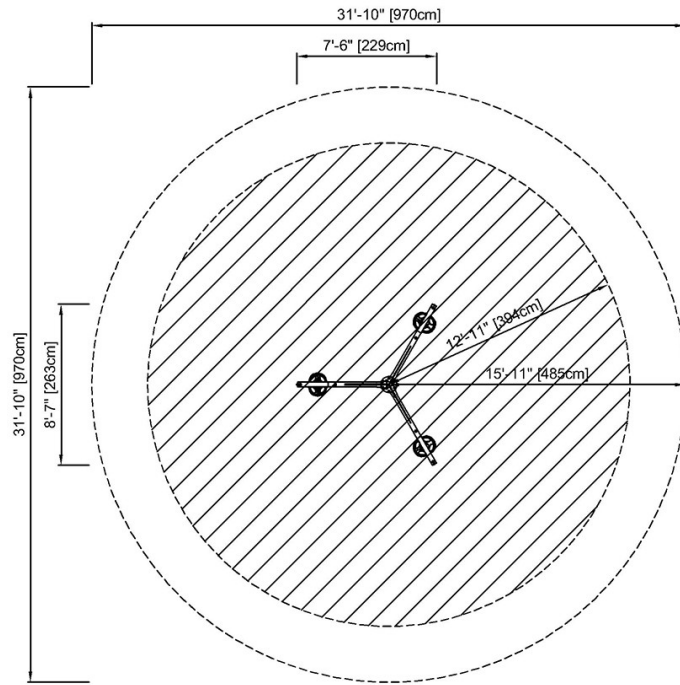

PCM154  
\* 4'-11" / 150cm  
\*\* 7'-9" / 236cm  
\*\*\* 795.5ft<sup>2</sup> / 73.9m<sup>2</sup>

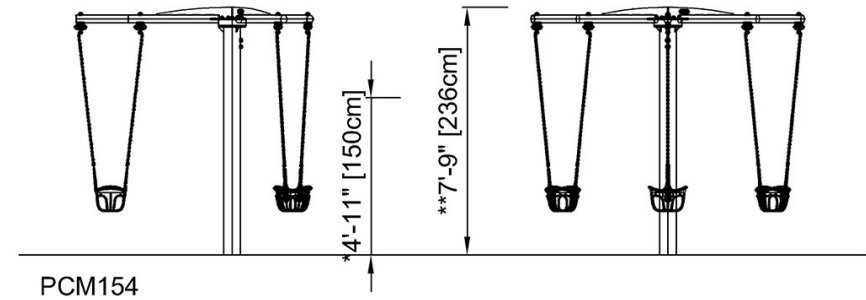

PCM154

[Click to see TOP VIEW](#)

[Click to see SIDE VIEW](#)