

Runner

PCE205131

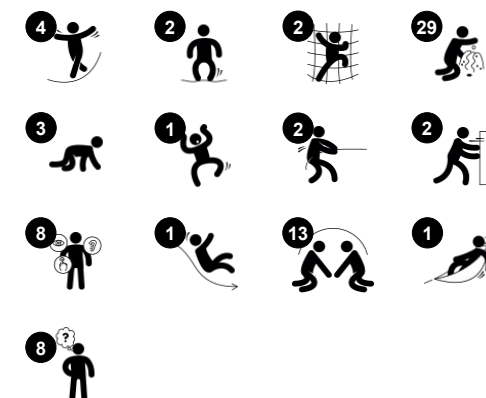

Item no. PCE205131-0603	
General Product Information	
Dimensions LxWxH	652x549x340 cm
Age group	2 - 5
Play capacity (users)	32
Colour options	● ● ●



The ultimate active play experience for toddlers, the Runner will cause them to return again and again. The Runner offers crawling through the tunnel, a great trainer of cross-coordination which is crucial for the development of the left and right sides of brain and necessary for functions like reading. The nice corner for sensory play with sand funnels

and the great music panel develops objects permanence and logical thinking. The talking tubes, the turning plate and the round window add additional sensory activities on ground level, throughout the Runner. The membrane bridge offers a fun jumping activity that builds turn-taking skills. When jumping, children gain vestibular input and build bone density. The low

slide is a stomach tickling balance trainer. It is placed so that toddlers of all abilities can easily loop in and out. The ground level base offers play for all.

Runner

PCE205131



Slide

Physical: sliding develops spatial awareness and a sense of balance. Furthermore, the core muscles are trained when sitting upright going down. **Social-Emotional:** empathy stimulated by turn-taking. **Cognitive:** young children develop their understanding of space, speed and distances when sliding down quickly.



Xylophone music panel

Social-Emotional: invites social interaction and co-creation for more children, on both sides. **Cognitive:** understanding of cause and effect when striking tubes and creating sound. **Creative:** the creation of different intensity and tonality stimulates creative skills.



Talk tube

Social-Emotional: encourages communication and social interaction. **Cognitive:** evokes curiosity and stimulates an understanding of cause and effect and object permanence: objects and persons exist also when out of sight.



Bubble Window

Social-Emotional: invites interaction between outside and inside. **Cognitive:** distorts the sound of the voice, developing logical thinking.

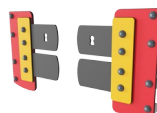

Flap door

Physical: tactile stimulation from leaning the body through rubber doors. **Cognitive:** suggests a theme and supports dramatic play, which stimulates language and communication skills.



Hammock

Physical: coordination and sense of balance when swaying. **Social-Emotional:** meeting, pushing friends gently back and forth, turn-taking. **Cognitive:** for toddlers cause and effect understanding.



Sand scoops panel

Physical: hand eye coordination and push-pull movements. **Social-Emotional:** invites cooperation due to the two-sidedness and provides for parallel play. **Cognitive:** logical thinking: cause and effect understanding when running scoops in grooves or shifting materials from scoop to scoop. **Creative:** shifting scoops, creating new scoop positions.

Runner

PCE205131



The Curved ELEMENTS panels are moulded of UV stabilised recyclable PE using 33% post-consumer recycled material. With multiple options for in-build play features that also ensures a strong panel solution. Straight panels are made of KOMPAN 19mm HDPE EcoCore™ which is a highly durable, ecofriendly and recyclable material made from +95% PCM.

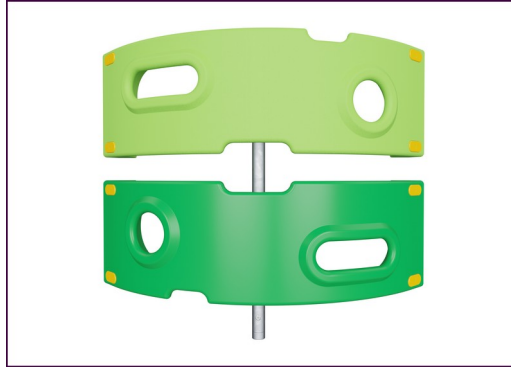

The climbing elements displayed are moulded from 33% post-consumer recycled materials in one piece, with a minimum 5mm wall thickness. The climbing elements are made of recyclable PE which has a high impact resistance across a wide temperature span which ensures vandal resistance in all locations.

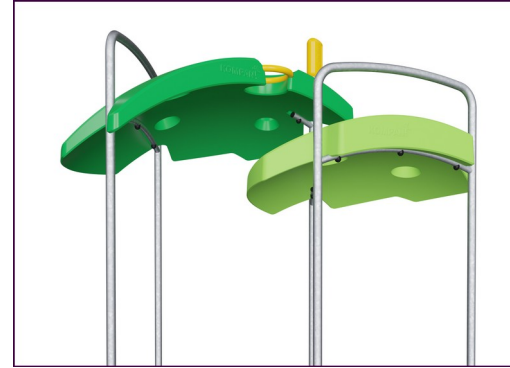

The ELEMENTS roofs are made of recyclable PE made from 33% post consumer recycled materials with a minimum wall thickness of 5 mm to ensure high durability in all climates around the world. The steel pipes are hot dip galvanised inside and outside for maximum durability.

Item no. PCE205131-0603	
Installation Information	
Max. fall height	133 cm
Safety surfacing area	68.3 m ²
Total installation time	32.8
Excavation volume	0.86 m ³
Concrete volume	0.08 m ³
Footing depth (standard)	80 cm
Shipment weight	1,011 kg
Anchoring options	Surface ✓ In-ground ✓
Warranty Information	
Curved panels	10 years
EcoCore HDPE	Lifetime
Membrane	2 years
Post	10 years
Spare parts guaranteed	10 years



The main posts are made of high quality pregalvanized steel with powder coated top finish. Post tops are closed with caps of UV stabilized nylon (PA6). The grey colored molded decks are made of 75% post-consumer waste PP material with a non-skid pattern and texture surface. All decks are supported by unique designed low-carbon aluminum profiles with multiple attachment options.

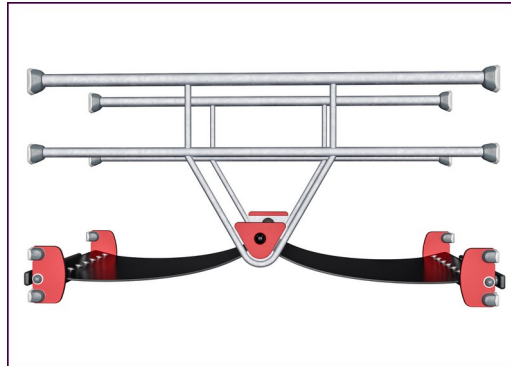

ELEMENTS rubber membranes are conveyer belt made of layers of rubber mixed of natural rubber and SBR rubber, and embedded with layers of armouring made of woven PE and PA. The thickness 8mm ensures high durability in any environment.

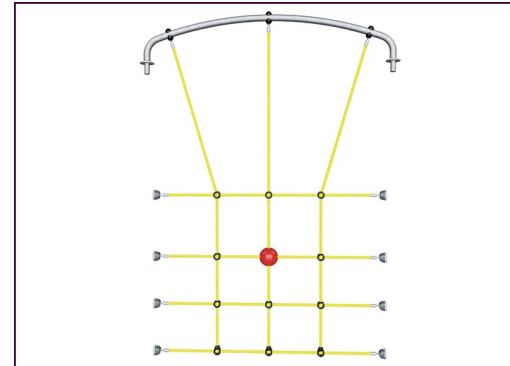

ELEMENTS ropes has six-stranded steel wires and a steel wire core. Each strand is tightly wrapped with PES yarn, which is made from +95% post consumer materials. The yarn is then melted onto each individual strand making the ropes highly wear- and vandalism-resistant.

Elevated activities 8	Accessible elevated activities	Accessible ground level activities	Accessible ground level play types
Present	8	4	3
Required	4	3	3

**CSA
Z614**
compliant

Sustainability Data

PCE205131



Cradle to Gate A1-A3	Total CO ₂ emission	CO ₂ e/kg	Recycled materials
	kg CO ₂ e	kg CO ₂ e/kg	%
PCE205131-0603	2,073.13	2.65	45.72

The overall framework applied for these factors is the Environmental Product Declaration (EPD), which quantifies "environmental information on the life cycle of a product and enable comparisons between products fulfilling the same function" (ISO, 2006). This follows the structure and applies a Life-Cycle Assessment approach to the entire Product stage from raw material through manufacturing (A1-A3))

Kompan A/S
 C.F. Tietgens Boulevard 32C
 DK-5220 Odense SØ
 Denmark



Verification of CO₂ calculation of: Play systems



Data version no. 2023-10-05

The CO₂ calculation and data are in compliance with the principles of a carbon footprint impact according to the GHG protocol (Greenhouse Gas Protocol), Scope 3, cradle to gate related to all individual components in the product category: "Play systems" represented by item no.: PCM200321-0950.

(Scope 3 emissions include emission sources in the upstream and downstream value chain).

Date: 30. October 2023 | Valid until: 30. October 2025

Verified by:

Julie Marie Vejsgaard Larsen, LCA & EPD Consultant

Verification based on report: Validation of CO₂ calculation of 9 categories of Kompan product line, version 1.0, prepared by: Bureau Veritas HSE, Denmark: Julie M. V. Larsen.

Publication date: 30. October 2023

By Bureau Veritas HSE
 www.bureauveritas.dk
 +45 7731 1000



Runner

PCE205131

* Max fall height | ** Total height | *** Safety surfacing area

* Max fall height | ** Total height

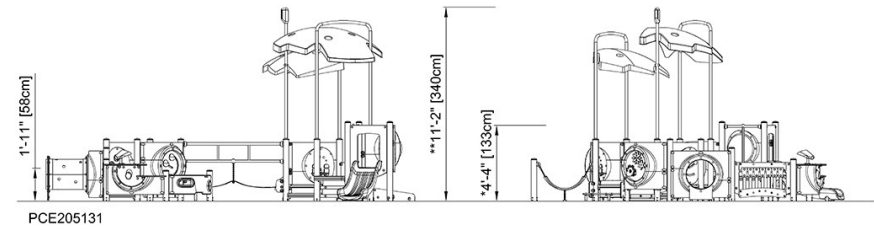
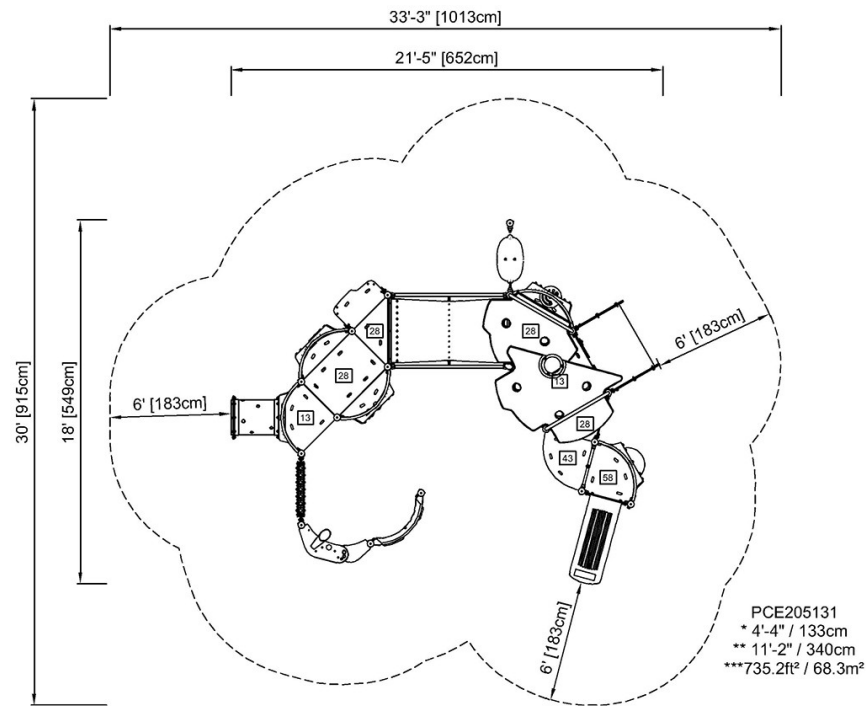

[Click to see TOP VIEW](#)

[Click to see SIDE VIEW](#)