

# Twist & Flex Wheel

FSW236



Item no. FSW23600-0902

## General Product Information

Dimensions LxWxH 80x118x165 cm

Age group 13+

Play capacity (users) 2

Color options

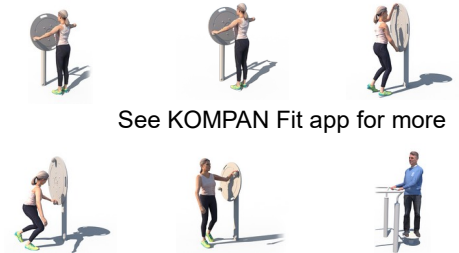

See KOMPAN Fit app for more

This station is focused on mobility and improving the range of motion of the upperbody and core. The Flex Wheel is simple to use and requires little experience beforehand. The turning movement has a mild resistance suitable for users at all levels. The ergonomically designed handles allow for natural wrist position and gives the user the

opportunity to do exercises from multiple positions. The wheel will train shoulder and upper body mobility.

The twist can be used for rotational flexibility of the torso and for lower limb, the user can add balance as part of the training by standing on one leg and closing the eyes while doing the exercises.



# Twist & Flex Wheel

FSW236



The bearings used in the Twist are slide bearings made of polyoxymethylene, a material that has all the properties needed for a strong bearing: extremely low wear, high mechanical strength, Low moisture absorption and High abrasion resistance.



The ø414mm top plate is made from 15mm Ekogrip®, a 15mm PE plate with a 3mm top-layer of thermoplastic rubber with non-skid effect. The height is 217mm and the range of motion is +/- 90°, with a EPDM rubber stop at each end.



The information sign is made of a PA6 (Polyamide) and shows the most relevant exercise and a QR code. When scanned the QR code will link to an animated illustration of the exercise and offers the possibility of downloading the KOMPAN sport & fitness App, which will provide a large amount of exercises and workouts.

Item no. FSW23600-0902

### Installation Information

Max. fall height	21 cm
Safety surfacing area	12.9 m <sup>2</sup>
Total installation time	4.0
Excavation volume	0.28 m <sup>3</sup>
Concrete volume	0.14 m <sup>3</sup>
Footing depth (standard)	90 cm
Shipment weight	87 kg
Anchoring options	



The bearing house is made from hot dip galvanised steel. The bearing shaft is made from stainless steel AISI304. The bearing itself is made from Polyoxymethylene (POM), an engineering thermoplastic with a high stiffness, low friction, and excellent dimensional stability.



The ball grips are ø80mm and are made from black, vacuum formed polycarbonate (PC). Polycarbonate is extremely strong and can withstand a very high impact.



The ø800x19mm wheel is made from HDPE EcoCore™ plate. EcoCore™ is a highly durable, ecofriendly material, which is not only recyclable after use, but is also made of +95% recycled post-consumer material from e.g., food packing waste in both core and colorful outer layer.



# Sustainability Data

FSW236



Cradle to Gate A1-A3	Total CO <sub>2</sub> emission	CO <sub>2</sub> e/kg	Recycled materials
	kg CO <sub>2</sub> e	kg CO <sub>2</sub> e/kg	%
<b>FSW23600-0902</b>	170.50	2.77	52.70

The overall framework applied for these factors is the Environmental Product Declaration (EPD), which quantifies "environmental information on the life cycle of a product and enable comparisons between products fulfilling the same function" (ISO, 2006). This follows the structure and applies a Life-Cycle Assessment approach to the entire Product stage from raw material through manufacturing (A1-A3))

**Kompan A/S**  
C.F. Tietgens Boulevard 32C  
DK-5220 Odense SØ  
Denmark



## Verification of CO<sub>2</sub> calculation of: Fitness



Data version no. 2023-10-05

The CO<sub>2</sub> calculation and data are in compliance with the principles of a carbon footprint impact according to the GHG protocol (Greenhouse Gas Protocol), Scope 3, cradle to gate related to all individual components in the product category: "Fitness" represented by item no.: FAZ10100-0900.

(Scope 3 emissions include emission sources in the upstream and downstream value chain).

**Date: 30. October 2023 | Valid until: 30. October 2025**

Verified by:

Julie Marie Vejsgaard Larsen, LCA & EPD Consultant

Verification based on report: Validation of CO<sub>2</sub> calculation of 9 categories of Kompan product line, version 1.0, prepared by: Bureau Veritas HSE, Denmark: Julie M. V. Larsen.

**Publication date: 30. October 2023**

By Bureau Veritas HSE  
www.bureauveritas.dk  
+45 7731 1000



# Twist & Flex Wheel

FSW236

\* Max fall height | \*\* Total height | \*\*\* Safety surfacing area

\* Max fall height | \*\* Total height

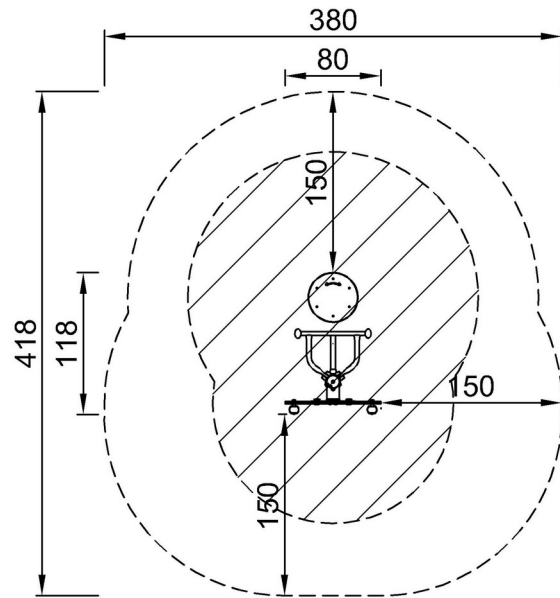

FSW23600  
\*21cm  
\*\*165cm  
\*\*\*12.9m<sup>2</sup>

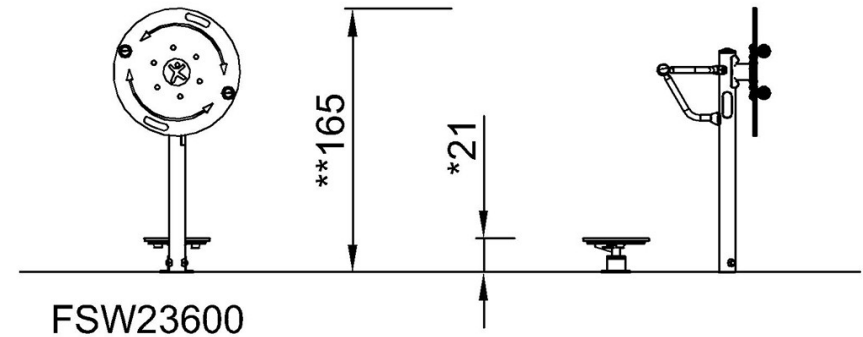

[Click to see TOP VIEW](#)

[Click to see SIDE VIEW](#)