

# Village Tower with Slide

NRO1011



Item no. NRO1011-1021

## General Product Information

Dimensions LxWxH	279x407x415 cm
Age group	4+
Play capacity (users)	5
Color options	

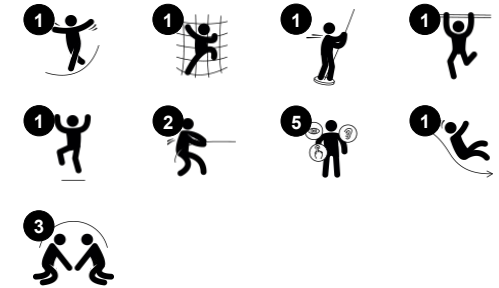

Impressive amounts of play in little space: The Village Tower with Slide inspires young children to play actively again and again. The inclined climber access provides an age-appropriate challenge to strengthen muscles and help develop cross-coordination. This enhances the cross-modal perception which again is fundamental for instance for reading skills. But

thrill is everything in playground play: from the platform, a great slide or a wild fireman's pole lead back to ground level. Sliding is immensely thrilling. It also supports posture and balance, which are fundamental for other physical skills. The Fireman's pole stimulates risk-taking and trains upper body muscles as children hold tight when whizzing down to the ground. The

slide and fireman's pole additionally build turn-taking and negotiation skills. On ground level, a nice space with play table invites meetings and conversations. This is a great asset which enhances the number of players and adds the possibility to socialize and build friendships.

# Village Tower with Slide

NRO1011



## Counter

**Physical:** invites climbing, developing cross coordination. This supports cross-modal perception, which is necessary for skills such as reading. **Social-Emotional:** sharing and cooperation from both sides create a social scenario supporting communication and cooperation. **Cognitive:** the counter invites dramatic play scenarios such as playing shop. This stimulates language and communication.



## Rock climber

**Physical:** supports cross coordination and leg, arm and hand strength. The hand-holds on top ease entry into platform. **Social-Emotional:** the inclination makes climbing feel secure, especially for younger children.



## Fireman's pole

**Physical:** coordination is supported when going down, as well as arm and core muscles. Landing strengthens bone density, which is built for life in early childhood. **Social-Emotional:** turn-taking and risk-taking.

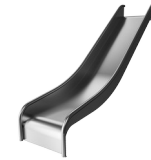

## Slide

**Physical:** sliding develops spatial awareness and a sense of balance. Furthermore, the core muscles are trained when sitting upright going down. **Social-Emotional:** empathy stimulated by turn-taking.

# Village Tower with Slide

NRO1011



All Organic Robinia products by KOMPAN are made of Robinia wood from sustainable European sources. On request it can be supplied as FSC® Certified (FSC® C004450).



The paint used for coloured components is water based environmentally friendly with excellent UV resistance. The paint is in compliance with EN 71 Part 3.



The Robinia products are designed with a KOMPAN colour concept with a number of different standard colours. The wood can also be supplied as untreated or with brown painted with a pigment that maintains the wood colour.

Item no. NRO1011-1021

## Installation Information

Max. fall height	206 cm
Safety surfacing area	31.4 m <sup>2</sup>
Total installation time	17.1
Excavation volume	0.74 m <sup>3</sup>
Concrete volume	0.13 m <sup>3</sup>
Footing depth (standard)	100 cm
Shipment weight	882 kg
Anchoring options	In-ground ✓



The stainless steel slides with one piece slide bed are made of high quality stainless steel AISI 304.



The stainless-steel activities are made of high-quality stainless steel. The steel is cleaned by a total pickling process after manufacturing to ensure a smooth and clean gliding surfaces.

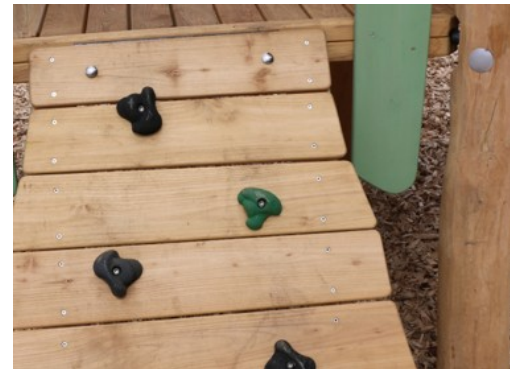

The hardware is made of stainless steel or galvanised steel to ensure durable connections with a high corrosion resistance.



# Sustainability Data

NRO1011



Cradle to Gate A1-A3	Total CO <sub>2</sub> emission	CO <sub>2</sub> e/kg	Recycled materials
	kg CO <sub>2</sub> e	kg CO <sub>2</sub> e/kg	%
<b>NRO1011-1021</b>	389.35	0.56	5.94

The overall framework applied for these factors is the Environmental Product Declaration (EPD), which quantifies "environmental information on the life cycle of a product and enable comparisons between products fulfilling the same function" (ISO, 2006). This follows the structure and applies a Life-Cycle Assessment approach to the entire Product stage from raw material through manufacturing (A1-A3))

**Kompan A/S**  
 C.F. Tietgens Boulevard 32C  
 DK-5220 Odense SØ  
 Denmark



## Verification of CO<sub>2</sub> calculation of: Nature play



Data version no. 2023-10-05

The CO<sub>2</sub> calculation and data are in compliance with the principles of a carbon footprint impact according to the GHG protocol (Greenhouse Gas Protocol), Scope 3, cradle to gate related to all individual components in the product category: "Nature play" represented by item no.: NRO409-0621.

(Scope 3 emissions include emission sources in the upstream and downstream value chain).

**Date: 30. October 2023 | Valid until: 30. October 2025**

**Verified by:**

Julie Marie Vejsgaard Larsen, LCA & EPD Consultant

Verification based on report: Validation of CO<sub>2</sub> calculation of 9 categories of Kompan product line, version 1.0, prepared by: Bureau Veritas HSE, Denmark: Julie M. V. Larsen.

**Publication date: 30. October 2023**

**By Bureau Veritas HSE**  
 www.bureauveritas.dk  
 +45 7731 1000



# Village Tower with Slide

NRO1011

\* Max fall height | \*\* Total height | \*\*\* Safety surfacing area

\* Max fall height | \*\* Total height

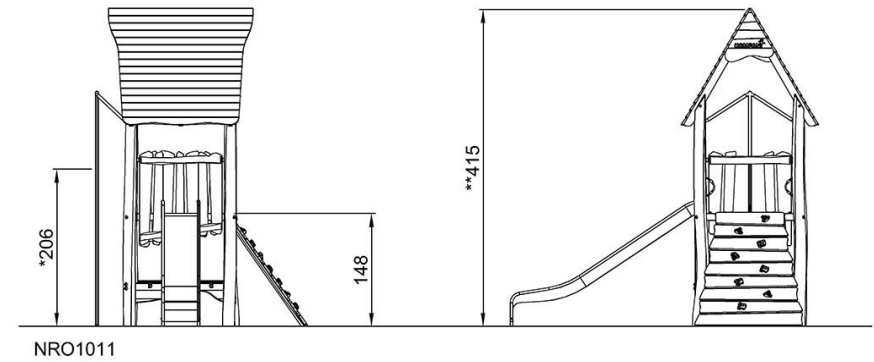
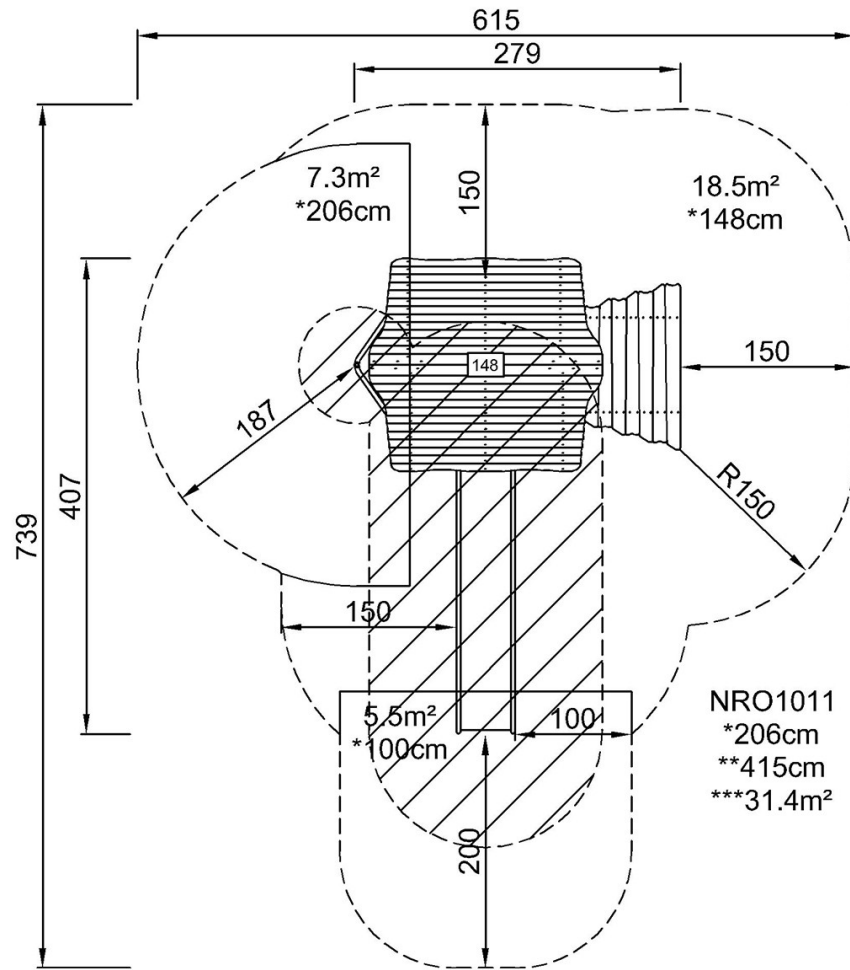

[Click to see TOP VIEW](#)

[Click to see SIDE VIEW](#)