

Petrol Pump 2

NRO519



Item no. NRO519-0601	
General Product Information	
Dimensions LxWxH	19x45x108 cm
Age group	2+
Play capacity (users)	1
Colour options	



This Gas pump 2 is great for any tricycle track or traffic play theme. It will appeal to role play around the themes of driving and traffic, which is always a great imaginative support for the child. This will add attraction and play time. The Gas Pump is made in rope, and the handle is quite elaborate in combination with the red, green and yellow buttons for choosing the right

octane strength. All in all the variety of materials stimulates the fine motor skills and tactile sense, especially for the youngest players. The dramatic play around traffic and gas stations stimulates the child's cognitive development in evoking storytelling and imagination. This supports the child's thinking skills along with the ability to negotiate and

empathize, both important skills in making great play companions.



Petrol Pump 2

NRO519



Theme

Cognitive: suggests a theme and supports dramatic play, which stimulates language and communication skills.



Fuel handle

Social-Emotional: cooperation skills and turn-taking are supported when fueling vehicles for friends. **Cognitive:** dramatic play stimulates language development.

Petrol Pump 2

NRO519



All Organic Robinia products by KOMPAN are made of Robinia wood from sustainable European sources. On request it can be supplied as FSC® Certified (FSC® C004450).



The paint used for coloured components is water based environmentally friendly with excellent UV resistance. The paint is in compliance with EN 71 Part 3.



Ropes are made of UV-stabilised PA with inner steel cable reinforcement. The rope is induction treated in order to create a strong connection between steel and rope which leads to good wear resistance.

Item no. NRO519-0601	
Installation Information	
Max. fall height	0 cm
Safety surfacing area	8.7 m ²
Total installation time	1.4
Excavation volume	0.08 m ³
Concrete volume	0.00 m ³
Footing depth (standard)	60 cm
Shipment weight	40 kg
Anchoring options	In-ground ✓ Surface ✓
Warranty Information	
Robinia wood	15 years
Spare parts guaranteed	10 years
Stainless steel components	Lifetime



Robinia products are available in three different wood treatment options: Untreated Robinia wood or brown painted with a pigment that maintains the wood colour and coloured version with paint of selected components.



Sustainability Data

NRO519



Cradle to Gate A1-A3	Total CO ₂ emission	CO ₂ e/kg	Recycled materials
	kg CO ₂ e	kg CO ₂ e/kg	%
NRO519-0601	10.16	0.32	2.51

The overall framework applied for these factors is the Environmental Product Declaration (EPD), which quantifies "environmental information on the life cycle of a product and enable comparisons between products fulfilling the same function" (ISO, 2006). This follows the structure and applies a Life-Cycle Assessment approach to the entire Product stage from raw material through manufacturing (A1-A3))

Kompan A/S
 C.F. Tietgens Boulevard 32C
 DK-5220 Odense SØ
 Denmark



Verification of CO₂ calculation of: Nature play



Data version no. 2023-10-05

The CO₂ calculation and data are in compliance with the principles of a carbon footprint impact according to the GHG protocol (Greenhouse Gas Protocol), Scope 3, cradle to gate related to all individual components in the product category: "Nature play" represented by item no.: NRO409-0621.

(Scope 3 emissions include emission sources in the upstream and downstream value chain).

Date: 30. October 2023 | Valid until: 30. October 2025

Verified by:

Julie Marie Vejsgaard Larsen, LCA & EPD Consultant

Verification based on report: Validation of CO₂ calculation of 9 categories of Kompan product line, version 1.0, prepared by: Bureau Veritas HSE, Denmark: Julie M. V. Larsen.

Publication date: 30. October 2023

By Bureau Veritas HSE
 www.bureauveritas.dk
 +45 7731 1000



Petrol Pump 2

NRO519

* Max fall height | ** Total height | *** Safety surfacing area

* Max fall height | ** Total height

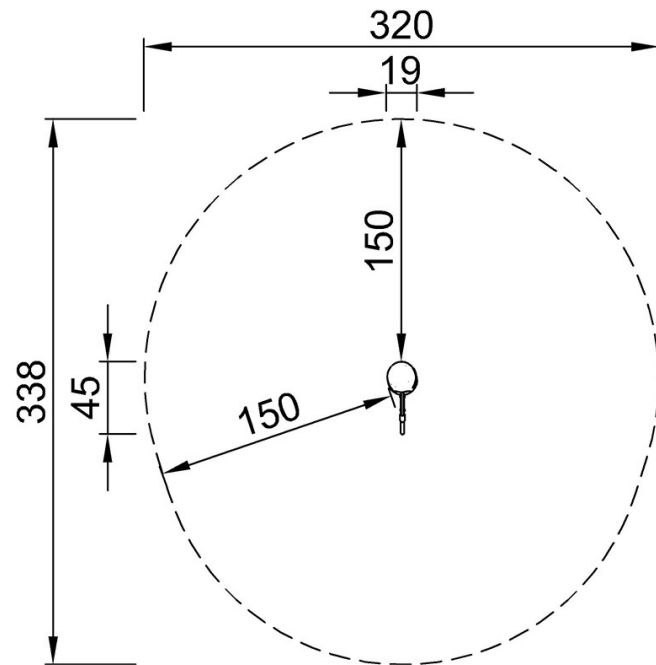

NRO519
**108cm
***8.7m²

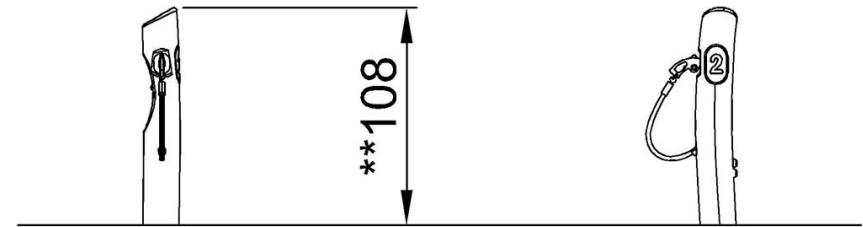

NRO519

[Click to see TOP VIEW](#)

[Click to see SIDE VIEW](#)