

# Two Towers with Wobbly Bridge

PCM200821

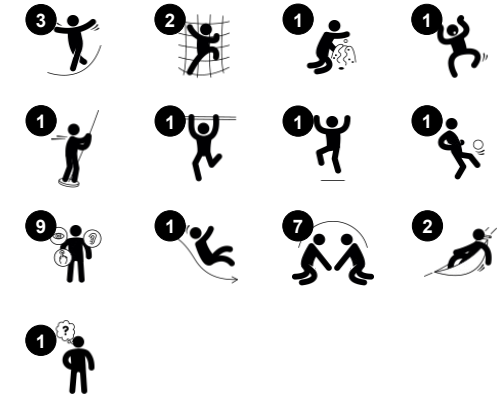

Item no. PCM200821-0651	
General Product Information	
Dimensions LxWxH	537x196x276 cm
Age group	2+
Play capacity (users)	14
Colour options	



The Two Towers with Wobbly Bridge offers playful social-emotional as well as physical growth for toddlers. The seating under the climbing tower with fireman's pole makes this a fun unit in its own right. The fireman's pole and inclined net entry point is for more experienced climbers, training risk-taking and proprioception. For children who want to play it

safer, the slide section allows for high-paced, cardio and balance packed looping, sliding down then climbing back up the steps. The wobble bridge invites thrilling balance training with friends, encouraging cooperation and consideration. It also trains the senses of balance and space, important for managing the world securely. The fun play panels and desk

encourage logical thinking skills and invite dramatic play supporting the development of children's language skills.



Data is subject to change without prior notice.

# Two Towers with Wobbly Bridge

PCM200821



## Balcony

**Social-Emotional:** the balcony invites meetings and interaction with people on ground level. **Cognitive:** invites dramatic play and performance, which stimulates language development.



## Slide

**Physical:** sliding develops spatial awareness and a sense of balance. Furthermore, the core muscles are trained when sitting upright going down. **Social-Emotional:** empathy stimulated by turn-taking. **Cognitive:** young children develop their understanding of space, speed and distances when sliding down quickly.



## Fireman's pole

**Physical:** coordination is supported when going down, as well as arm and core muscles. Landing strengthens bone density, which is built for life in early childhood. **Social-Emotional:** turn-taking and risk-taking. **Cognitive:** young children develop their understanding of space, speed and distances when gliding down fast.



## Climbing net

**Physical:** supports physical strength and cross-body coordination, which impacts coordination of the right and left part of brain, fundamental for other skills such as the ability to read.



## Desk

**Social-Emotional:** fine meeting place and a space creator. Sharing and cooperation from both sides create a social scenario that supports communication and cooperation.



## Wobble bridge

**Physical:** sense of balance and space, and training of posture. Important for being able to sit still. **Social-Emotional:** cooperation, turn-taking and friendly competition on the plates.

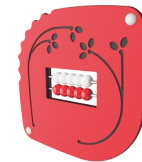

## Abacus

**Cognitive:** supports understanding of measures.

# Two Towers with Wobbly Bridge

PCM200821



Panels of 19mm EcoCore™. EcoCore™ is a highly durable, eco friendly material, which is not only recyclable after use, but is also produced from +95% recycled post consumer material from food packing waste. Wooden panels of impregnated and brown painted pine wood with vertical steel profiles.



Main posts with hot dip galvanized steel footing are available in different materials: Pressure impregnated pine wood posts. Pre-galvanized inside and outside with powder coated top finish steel posts. Lead free aluminum with color anodized top finish. Greenline TexMade posts of 95% post-consumer recycled PE and textile waste.

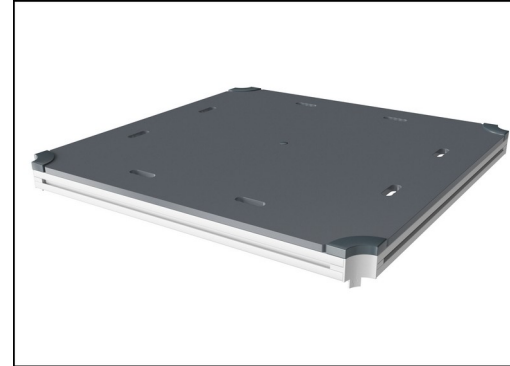

All decks are supported by unique designed low-carbon aluminum profiles with multiple attachment options. The grey colored molded decks are made of 75% post-consumer waste PP material with a non-skid pattern and texture surface.

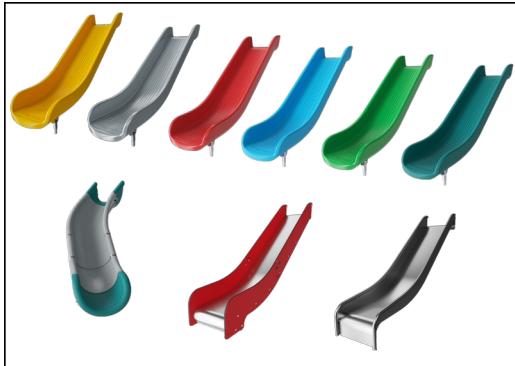

The slides can be chosen in six different colors and three materials: Straight or curved one-piece molded PE slides, made from 33% recycled post-consumer materials in different colours. Combined EcoCore™ sides and stainless-steel. Full stainless steel in one piece design for more vandalism proof solutions.



Coloured steel components have a base of hot dip galvanisation and a powder coated top finish. This provides an ultimate corrosion resistance in all climates around the world.



KOMPAN GreenLine versions are designed with ultimate environmentally friendly materials with lowest possible CO2e emission factor. TexMade post, EcoCore™ panels of 95% post-consumer recycled waste and molded PP decks.

Item no. PCM200821-0651

### Installation Information

Max. fall height	100 cm
Safety surfacing area	30.3 m <sup>2</sup>
Total installation time	14.5
Excavation volume	0.43 m <sup>3</sup>
Concrete volume	0.00 m <sup>3</sup>
Footing depth (standard)	60 cm
Shipment weight	479 kg
Anchoring options	In-ground ✓ Surface ✓

### Warranty Information

EcoCore HDPE	Lifetime
Post	10 years
PP Decks	10 years
Ropes & nets	10 years
Spare parts guaranteed	10 years



# Sustainability Data

PCM200821



Cradle to Gate A1-A3	Total CO <sub>2</sub> emission	CO <sub>2</sub> e/kg	Recycled materials
	kg CO <sub>2</sub> e	kg CO <sub>2</sub> e/kg	%
<b>PCM200821-0651</b>	640.40	1.90	62.82
<b>PCM200821-0605</b>	796.00	2.73	46.99

The overall framework applied for these factors is the Environmental Product Declaration (EPD), which quantifies "environmental information on the life cycle of a product and enable comparisons between products fulfilling the same function" (ISO, 2006). This follows the structure and applies a Life-Cycle Assessment approach to the entire Product stage from raw material through manufacturing (A1-A3))

**Kompan A/S**  
C.F. Tietgens Boulevard 32C  
DK-5220 Odense SØ  
Denmark



## Verification of CO<sub>2</sub> calculation of: Play systems



Data version no. 2023-10-05

The CO<sub>2</sub> calculation and data are in compliance with the principles of a carbon footprint impact according to the GHG protocol (Greenhouse Gas Protocol), Scope 3, cradle to gate related to all individual components in the product category: "Play systems" represented by item no.: PCM200321-0950.

(Scope 3 emissions include emission sources in the upstream and downstream value chain).

**Date: 30. October 2023 | Valid until: 30. October 2025**

Verified by:

Julie Marie Vejsgaard Larsen, LCA & EPD Consultant

Verification based on report: Validation of CO<sub>2</sub> calculation of 9 categories of Kompan product line, version 1.0, prepared by: Bureau Veritas HSE, Denmark: Julie M. V. Larsen.

**Publication date: 30. October 2023**

By Bureau Veritas HSE  
www.bureauveritas.dk  
+45 7731 1000



# Two Towers with Wobbly Bridge

PCM200821

\* Max fall height | \*\* Total height | \*\*\* Safety surfacing area

\* Max fall height | \*\* Total height

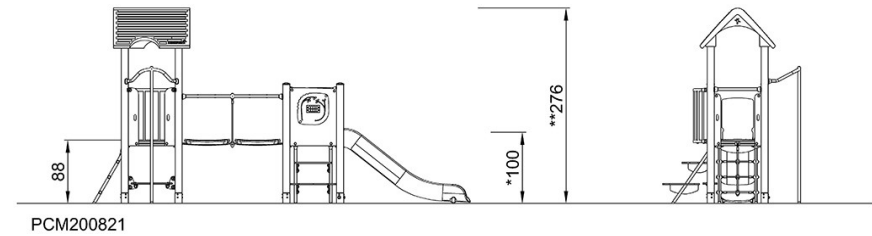
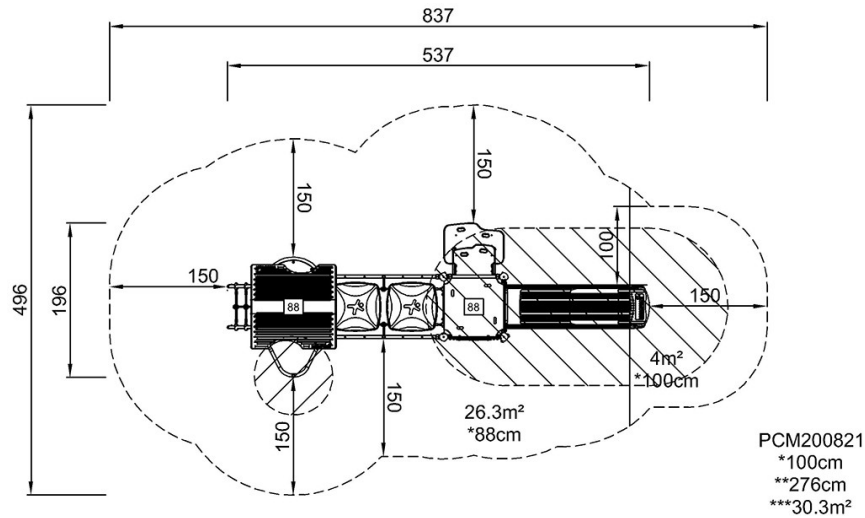

[Click to see TOP VIEW](#)

[Click to see SIDE VIEW](#)