

# Double Tower

KPL2011

**KOMPANI**  
Let's play



The vibrant colours and classic activities attract toddlers immensely. They play again and again, finishing the loops of climbing or crawling up, running over and sliding down. Apart from being great fun, climbing the climbing wall is a great brain trainer for toddlers. The cooperation of the left and right brain half is trained via cross-modal functions

such as alternating feet and arms in crawling and climbing. This is fundamental for later reading skills, for instance. Sliding from the Two Tower with Panel Bridge to toddlers provides a great thrill. It is a trainer of stability and spatial awareness, teaching the child about the speed of the body in space. These life skills are important in for instance judging

distances, when navigating the world securely, for instance in traffic. It's play that trains the brains of toddlers.

Item no. KPL201111-0601	
<b>General Product Information</b>	
Dimensions LxWxH	253x260x214 cm
Age group	1+
Play capacity (users)	9
Colour options	

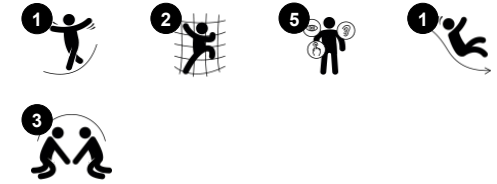

# Double Tower

KPL2011



## Slide

**Physical:** develops spatial awareness, sense of balance and trains core muscles when sitting upright going down. **Social-Emotional:** empathy stimulated by turn-taking. **Cognitive:** young children develop their understanding of space, speed and distances when sliding down.

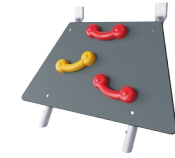

## Rock climber

**Physical:** supports cross coordination and leg, arm and hand strength. **Social-Emotional:** the inclination makes climbing feel secure, especially for younger children.



## Transfer step

**Physical:** extra spacious step to facilitate entrance for users with mobility impairments. **Social-Emotional:** spacious step for meeting and resting.



## Bridge

**Physical:** cross coordination, spatial awareness. **Social-Emotional:** transparency invite cooperation with children on the outside.

# Double Tower

KPL2011



Panels of 19mm EcoCore™. EcoCore™ is a highly durable, eco-friendly material, which is not only recyclable after use but also consists of a core produced from 100% recycled material.



The main tower posts are available in two types of material: European pine wood posts pressure impregnated Class 3 with Tanalith E preservative, or aluminium with an anodised surface treatment.

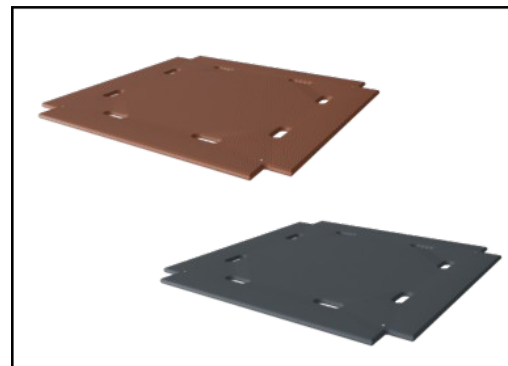

Floors and panel activities are manufactured from high-pressure laminate HPL with a thickness 17.8mm and non-skid surface texture.

Item no. KPL201111-0601

### Installation Information

Max. fall height	100 cm
Safety surfacing area	22.0 m <sup>2</sup>
Total installation time	12.4
Excavation volume	0.76 m <sup>3</sup>
Concrete volume	0.00 m <sup>3</sup>
Footing depth (standard)	60 cm
Shipment weight	271 kg
Anchoring options	In-ground ✓ Surface ✓

### Warranty Information

Aluminum	15 years
EcoCore HDPE	Lifetime
Hollow PE parts	10 years
Pinewood	10 years
Spare Parts Guarantee	10 years

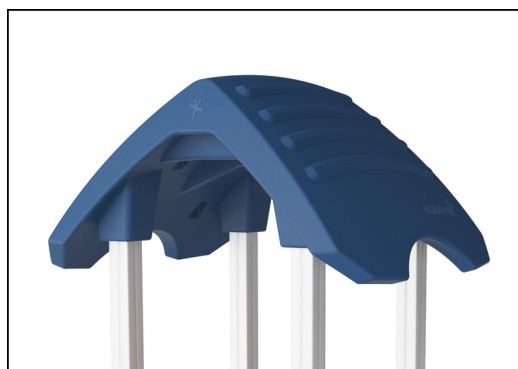

The large hollow components are made of 100% recyclable PE. The roof displayed is moulded in one piece with minimum 5,5mm wall thickness to ensure high durability in all climates around the world.

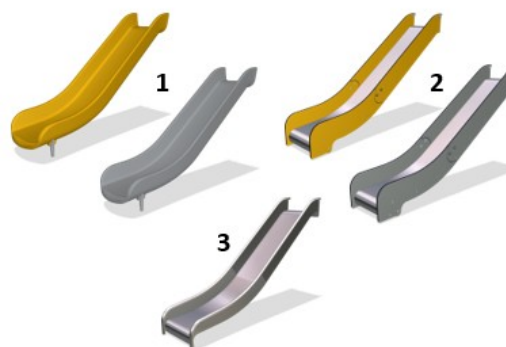

Slides are available in three different materials: moulded on piece PE slides, combined EcoCore™ sides and stainless steel slide bed t=2mm. Full stainless steel AISI304 t=2mm.

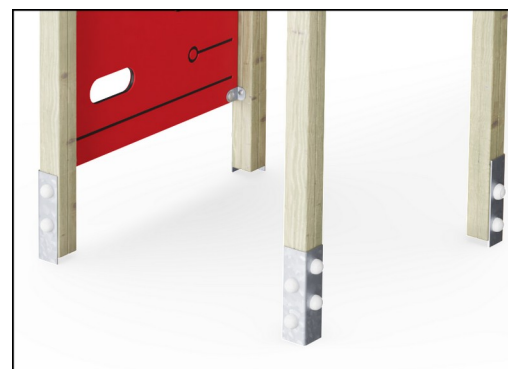

The main posts are equipped with hot-dip galvanised steel footings. The steel footings elevate the posts position 20mm from ground level to avoid contact with surfacing material.



# Sustainability Data

KPL2011



Cradle to Gate A1-A3	Total CO <sub>2</sub> emission	CO <sub>2</sub> e/kg	Recycled materials
	kg CO <sub>2</sub> e	kg CO <sub>2</sub> e/kg	%
<b>KPL201111-0601</b>	287.51	1.40	36.58

The overall framework applied for these factors is the Environmental Product Declaration (EPD), which quantifies "environmental information on the life cycle of a product and enable comparisons between products fulfilling the same function" (ISO, 2006). This follows the structure and applies a Life-Cycle Assessment approach to the entire Product stage from raw material through manufacturing (A1-A3))

**Kompan A/S**  
 C.F. Tietgens Boulevard 32C  
 DK-5220 Odense SØ  
 Denmark



## Verification of CO<sub>2</sub> calculation of: Play systems



Data version no. 2023-10-05

The CO<sub>2</sub> calculation and data are in compliance with the principles of a carbon footprint impact according to the GHG protocol (Greenhouse Gas Protocol), Scope 3, cradle to gate related to all individual components in the product category: "Play systems" represented by item no.: PCM200321-0950.

(Scope 3 emissions include emission sources in the upstream and downstream value chain).

**Date: 30. October 2023 | Valid until: 30. October 2025**

Verified by:

Julie Marie Vejsgaard Larsen, LCA & EPD Consultant

Verification based on report: Validation of CO<sub>2</sub> calculation of 9 categories of Kompan product line, version 1.0, prepared by: Bureau Veritas HSE, Denmark: Julie M. V. Larsen.

**Publication date: 30. October 2023**

By Bureau Veritas HSE  
 www.bureauveritas.dk  
 +45 7731 1000



# Double Tower

KPL2011

\* Max fall height | \*\* Total height | \*\*\* Safety surfacing area

\* Max fall height | \*\* Total height

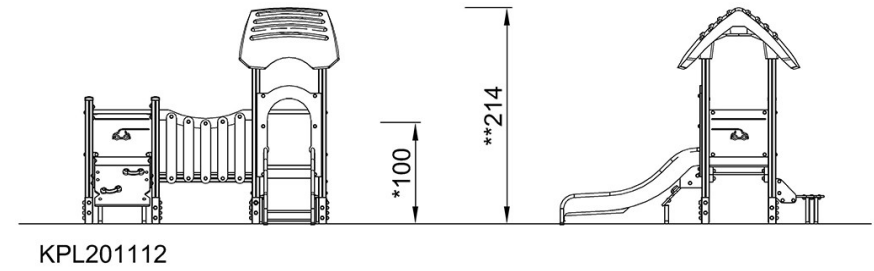
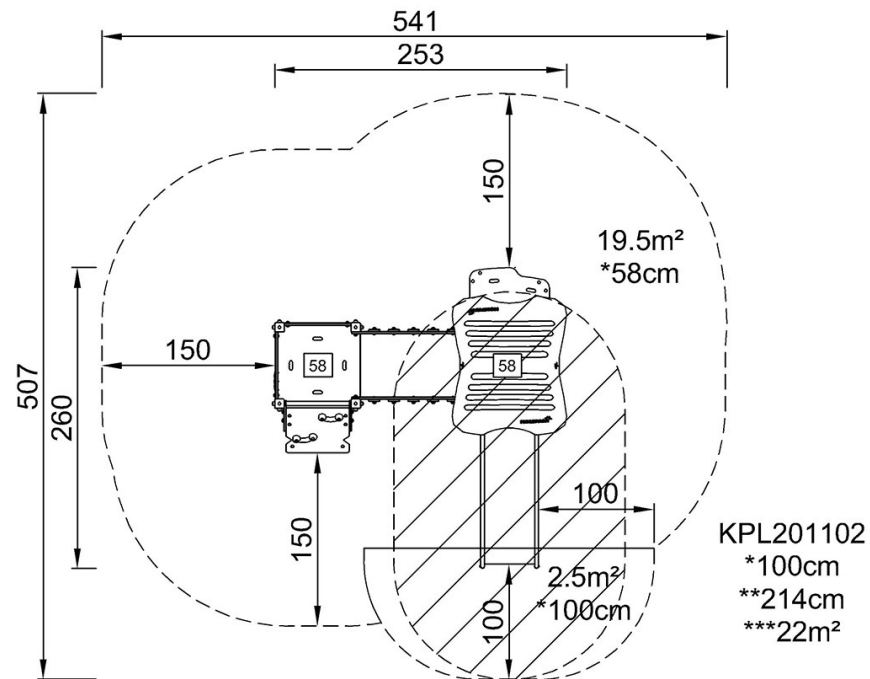

[Click to see TOP VIEW](#)

[Click to see SIDE VIEW](#)