

# Crane & Container

PCM52721

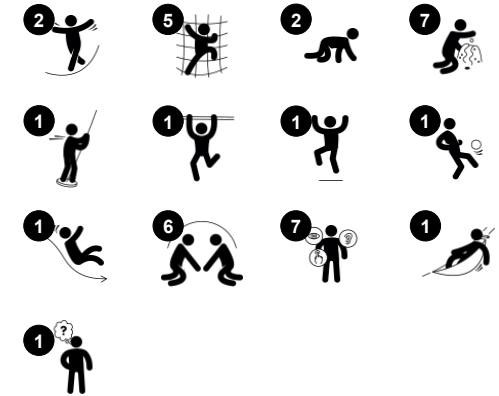

Item no. PCM52721-0901	
General Product Information	
Dimensions LxWxH	509x450x466 cm
Age group	6+
Play capacity (users)	21
Colour options	<span style="color: red;">●</span>



The Crane & Container intrigues young children and motivates play again and again. The platform with slide and fireman's pole offers a great look-out with nice play panels with gearing wheels. Children can access the platform by either the ladder or the climbing wall. Climbing is a favourite play activity and the choice of different climbing apart from being

a play attraction also trains children's cross-coordination and muscles. This builds fundamental movement skills that positively affect cross-modal perception and learning. Sliding, and not least gliding down the banister bars, is hugely thrilling. It also builds children's spatial awareness and trains their inner dare-devils. At and under the play platform a lovely

hideout offers socialising and a break from climbing.

# Crane & Container

PCM52721



## Slide

**Physical:** sliding develops spatial awareness and a sense of balance. Furthermore, the core muscles are trained when sitting upright going down. **Social-Emotional:** empathy stimulated by turn-taking.



## Theme

**Cognitive:** suggests a theme and supports dramatic play, which stimulates language and communication skills.



## Score board

**Social-Emotional:** teams can each have a button to measure rounds, wins etc. The buttons support cooperation and teamwork. **Cognitive:** counting and registering support thinking skills such as logical thinking and sequencing.



## Megaphone

**Social-Emotional:** inspires communication and turn-taking skills. **Cognitive:** distortion of sound evokes curiosity and stimulates an understanding of cause and effect.



## Climbing rope

**Physical:** the small knots add support for hands and feet when climbing onto the rope, crawling up or down. Climbing supports spatial awareness, cross coordination and muscle strength. **Social-Emotional:** passing others when climbing up or down develops turn-taking skills and consideration.



## Hammock

**Physical:** coordination and sense of balance when swaying. **Social-Emotional:** meeting, pushing friends gently back and forth, turn-taking.



## Banister bars

**Physical:** coordination is supported when going down, as well as arm and core muscles. Landing strengthens bone density, which is built for life in childhood. **Social-Emotional:** turn-taking and risk-taking.

# Crane & Container

PCM52721



Panels of 19mm EcoCore™. EcoCore™ is a highly durable, eco friendly material, which is not only recyclable after use, but also consists of material produced from +95% recycled post consumer material from food packing waste.



Main posts with hot dip galvanized steel footing are available in different materials: Pre-galvanized inside and outside with powder coated top finish steel posts. Lead free aluminum with color anodized top finish. TexMade posts of 95% post-consumer recycled PE and textile waste.



All decks are supported by unique designed low-carbon aluminum profiles with multiple attachment options. The grey colored molded decks are made of 75% post-consumer waste PP material with a non-skid pattern and texture surface.

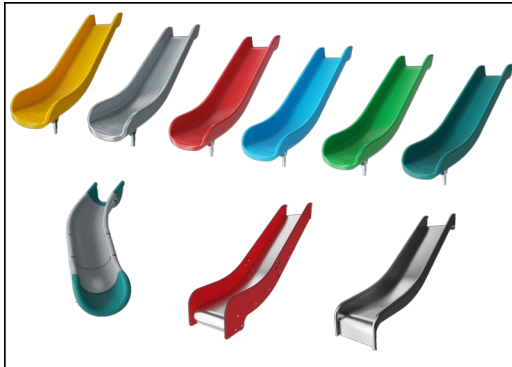

The slides can be chosen in six different colours and three materials: Straight or curved one-piece molded PE slides; Combined EcoCore™ and stainless-steel slides; Full stainless steel in one-piece design for a more vandalism proof solution.

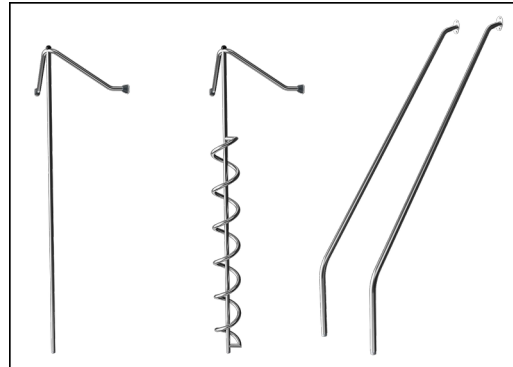

The stainless-steel activities are made of high-quality stainless steel. The steel is cleaned by a total pickling process after manufacturing to ensure a smooth and clean gliding surfaces.



KOMPAN GreenLine versions are designed with ultimate environmentally friendly materials with lowest possible CO2e emission factor. TexMade post, EcoCore™ panels of 95% post-consumer recycled waste and molded PP decks.

Item no. PCM52721-0901

### Installation Information

Max. fall height	239 cm
Safety surfacing area	39.6 m <sup>2</sup>
Total installation time	23.2
Excavation volume	0.79 m <sup>3</sup>
Concrete volume	0.14 m <sup>3</sup>
Footing depth (standard)	90 cm
Shipment weight	781 kg
Anchoring options	Surface ✓ In-ground ✓

### Warranty Information

EcoCore HDPE	Lifetime
Post	10 years
PP Decks	10 years
Spare parts guaranteed	10 years
Stainless steel components	Lifetime

# Sustainability Data

PCM52721



Cradle to Gate A1-A3	Total CO <sub>2</sub> emission	CO <sub>2</sub> e/kg	Recycled materials
	kg CO <sub>2</sub> e	kg CO <sub>2</sub> e/kg	%
<b>PCM52721-0901</b>	1,049.89	1.90	66.97

The overall framework applied for these factors is the Environmental Product Declaration (EPD), which quantifies "environmental information on the life cycle of a product and enable comparisons between products fulfilling the same function" (ISO, 2006). This follows the structure and applies a Life-Cycle Assessment approach to the entire Product stage from raw material through manufacturing (A1-A3))

**Kompan A/S**  
C.F. Tietgens Boulevard 32C  
DK-5220 Odense SØ  
Denmark



## Verification of CO<sub>2</sub> calculation of: Play systems



Data version no. 2023-10-05

The CO<sub>2</sub> calculation and data are in compliance with the principles of a carbon footprint impact according to the GHG protocol (Greenhouse Gas Protocol), Scope 3, cradle to gate related to all individual components in the product category: "Play systems" represented by item no.: PCM200321-0950.

(Scope 3 emissions include emission sources in the upstream and downstream value chain).

**Date: 30. October 2023 | Valid until: 30. October 2025**

Verified by:

Julie Marie Vejsgaard Larsen, LCA & EPD Consultant

Verification based on report: Validation of CO<sub>2</sub> calculation of 9 categories of Kompan product line, version 1.0, prepared by: Bureau Veritas HSE, Denmark: Julie M. V. Larsen.

**Publication date: 30. October 2023**

By Bureau Veritas HSE  
www.bureauveritas.dk  
+45 7731 1000



# Crane & Container

PCM52721

\* Max fall height | \*\* Total height | \*\*\* Safety surfacing area

\* Max fall height | \*\* Total height

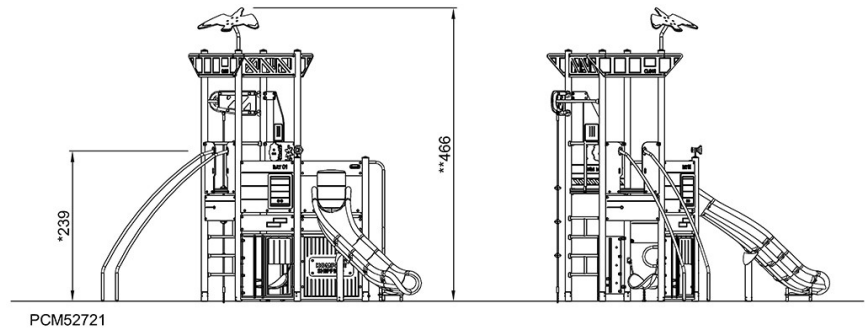
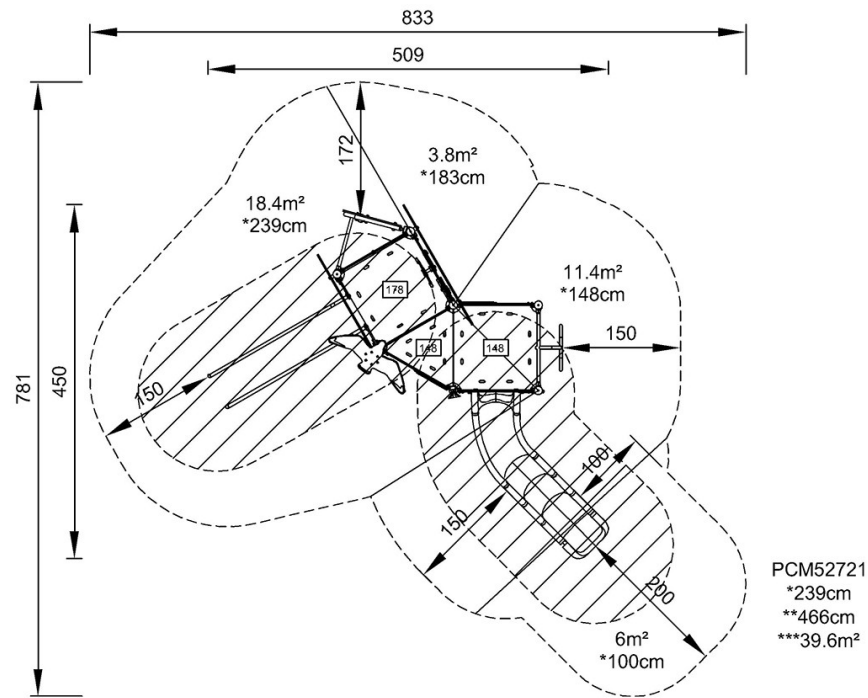

[Click to see TOP VIEW](#)

[Click to see SIDE VIEW](#)