

# Play Tower with Curly Climber & Net

PCM100431

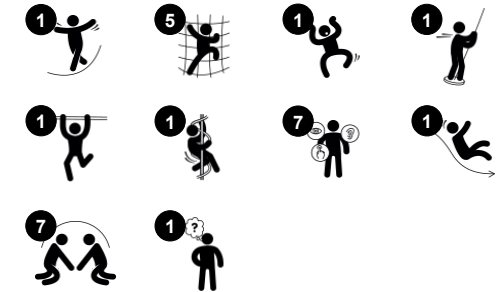

Item no. PCM100431-0902	
General Product Information	
Dimensions LxWxH	20'6"x11'10"x9'2"
Age group	2 - 5
Play capacity (users)	20
Color options	



This super play tower will attract children and encourage active physical play. The climbing wall and ADA stairs provide age-appropriate challenges that will strengthen leg muscles and provide a sense of accomplishment when it is mastered. Since there are multiple ways to climb on the climber, children can adjust their own challenges, and this results in extended

play. The climbing activities will support children's muscle development as well as their cross-coordination. These skills are important for health and well-being as well as for thinking and learning. For example, using both sides of your body to climb and navigate the structure stimulates both sides of the brain, essential for learning, particularly for literacy. Sliding down

the slide or gliding down the Fireman's Pole supports posture and balance, all important skills for young children, and great fun!



# Play Tower with Curly Climber & Net

PCM100431



## Curly climber

**Physical:** coordination and proprioception are supported when placing arms and legs correctly for going down. Sense of balance when rotating. Arm muscles for holding tight. **Social-Emotional:** empathy stimulated by turn-taking. **Cognitive:** logical thinking when placing arms and legs right for rotating downward.



## Accessible stairway

**Physical:** climbing the accessible stairway is for all and supports cross coordination as well as arm and leg muscles. For young children, walking stairs and alternating feet is developed. **Social-Emotional:** room for active breaks and adult helpers. An inclusive space.



## Window

**Social-Emotional:** invites interaction between sides and cooperative play.



## Slide

**Physical:** sliding develops spatial awareness and a sense of balance. Furthermore, the core muscles are trained when sitting upright going down. **Social-Emotional:** empathy stimulated by turn-taking. **Cognitive:** young children develop their understanding of space, speed and distances when sliding down quickly.



## Desk

**Social-Emotional:** fine meeting place and a space creator. Sharing and cooperation from both sides create a social scenario that supports communication and cooperation.



## Climbing net

**Physical:** children develop cross-body coordination and muscle strength when climbing. The big meshes allow for climbing and crawling through, supporting proprioception and spatial awareness. **Social-Emotional:** the big meshes allow for more children to sit together and talk.



## Pipe ladder

**Physical:** cross coordination and eye-hand coordination are supported when children climb the ladder. The climbing also supports leg and arm muscles. **Social-Emotional:** learning about taking turns and cooperation.

# Play Tower with Curly Climber & Net

PCM100431



Panels of 19mm EcoCore™. EcoCore™ is a highly durable, eco friendly material, which is not only recyclable after use, but also consists of a core produced from 100% recycled material.



Main posts with hot-dip galvanized steel footing are available in different materials: Pressure impregnated pinewood posts. Pre-galvanized inside and outside with powder-coated top finish steel posts. Lead-free aluminum with color anodized top finish. Greenline TexMade posts of 100% post-consumer recycled PE and textile waste.



All decks are supported by uniquely designed low-carbon aluminum profiles with multiple attachment options. The grey-colored molded decks are made of 75% post-consumer ocean waste PP material with a non-skid pattern and texture surface.



The slides can be chosen in six different colors and three materials: Straight or curved one-piece molded PE slides. Combined EcoCore™ sides and stainless steel. Full stainless steel in a one-piece design for more vandalism-proof solutions.

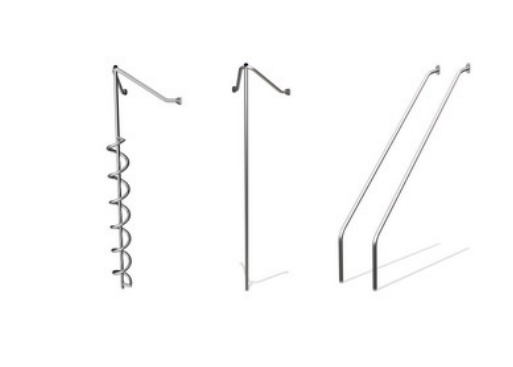

The stainless-steel activities are made of high-quality stainless steel. The steel is cleaned by a total pickling process after manufacturing to ensure a smooth and clean gliding surfaces.



KOMPAN GreenLine versions are constructed with the most environmentally friendly materials with the lowest possible CO2e emission factor. TexMade posts, EcoCore™ panels of 100% post-consumer recycled ocean waste, and molded PP decks.

Item no. PCM100431-0902	
Installation Information	
Max. fall height	7'4"
Safety surfacing area	535ft <sup>2</sup>
Total installation time	21.2
Excavation volume	0.78yd <sup>3</sup>
Concrete volume	0.03yd <sup>3</sup>
Footing depth (standard)	2'9"
Shipment weight	1353lbs
Anchoring options	In-ground ✓ Surface ✓
Warranty Information	
EcoCore HDPE	Lifetime
Post	10 Years
PP Decks	10 Years
Ropes & nets	10 Years
Spare Parts Availability	10 Years

Elevated activities 3	Accessible elevated activities	Accessible ground level activities	Accessible ground level play types
Present	3	1	1
Required	2	1	1

**ASTM F1487**  
compliant

# Sustainability Data

PCM100431



Cradle to Gate A1-A3	Total CO <sub>2</sub> emission	CO <sub>2</sub> e/kg	Recycled materials
	kg CO <sub>2</sub> e	kg CO <sub>2</sub> e/kg	%
<b>PCM100431-0951</b>	915.17	1.77	70.07
<b>PCM100431-0902</b>	1,149.40	2.47	58.42

The overall framework applied for these factors is the Environmental Product Declaration (EPD), which quantifies "environmental information on the life cycle of a product and enable comparisons between products fulfilling the same function" (ISO, 2006). This follows the structure and applies a Life-Cycle Assessment approach to the entire Product stage from raw material through manufacturing (A1-A3))

**Kompan A/S**  
 C.F. Tietgens Boulevard 32C  
 DK-5220 Odense SØ  
 Denmark



## Verification of CO<sub>2</sub> calculation of: Play systems



Data version no. 2023-10-05

The CO<sub>2</sub> calculation and data are in compliance with the principles of a carbon footprint impact according to the GHG protocol (Greenhouse Gas Protocol), Scope 3, cradle to gate related to all individual components in the product category: "Play systems" represented by item no.: PCM200321-0950.

(Scope 3 emissions include emission sources in the upstream and downstream value chain).

**Date: 30. October 2023 | Valid until: 30. October 2025**

Verified by:

Julie Marie Vejsgaard Larsen, LCA & EPD Consultant

Verification based on report: Validation of CO<sub>2</sub> calculation of 9 categories of Kompan product line, version 1.0, prepared by: Bureau Veritas HSE, Denmark: Julie M. V. Larsen.

**Publication date: 30. October 2023**

By Bureau Veritas HSE  
 www.bureauveritas.dk  
 +45 7731 1000



# Play Tower with Curly Climber & Net

PCM100431

\* Max fall height | \*\* Total height | \*\*\* Safety surfacing area

\* Max fall height | \*\* Total height

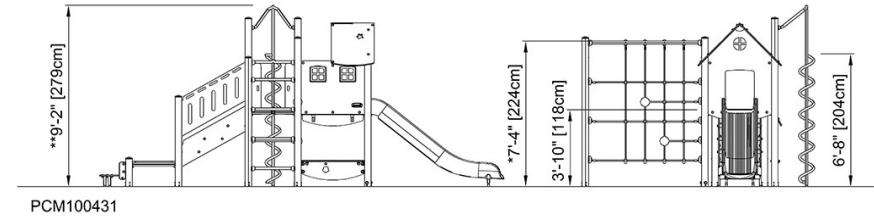
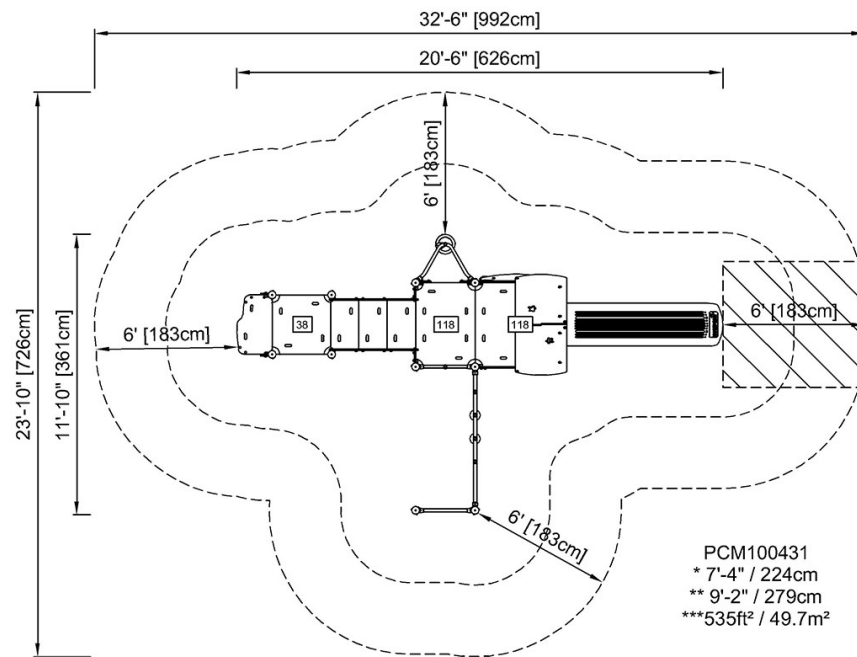

[Click to see TOP VIEW](#)

[Click to see SIDE VIEW](#)