

Horse Ride Seesaw

NAT104



Item no. NAT104-0712

General Product Information

Dimensions LxWxH	302x36x97 cm
Age group	4+
Play capacity (users)	2
Colour options	



The Horse Ride is a fun play magnet for primary and middle school children. Rocking on the Horse Ride is a thrilling physical and social activity. The middle bar accommodates friends who want to be rocked. The circular handholds allow for more hand hold heights. The calibrated rocking element provides a smooth rocking movement. Rocking is not only fun, but

it also stimulates physical and socio-emotional skills. The Horse Ride movements help to develop spatial awareness and the sense of balance. These are fundamental motor skills that help the child move confidently. The cooperation and turn-taking in seesawing build important social-emotional skills. These are important for building an understanding of

human interaction that will support the child's ability to build friendships, for life.



Horse Ride Seesaw

NAT104



Handhold

Physical: the possibility to hold on tight enables intense rocking. This trains the hand and arm muscles.



Rocking together

Social-Emotional: the possibility of rocking two together trains cooperation skills. Consideration of others when rocking.



Rocking movement

Physical: response to movements adds to spatial awareness and sense of balance. These are fundamental motor skills that help the child's ability to sit still on a chair which takes a good sense of balance. **Cognitive:** trains the understanding of cause and effect: when I move my body, the spring responds with movement.

Horse Ride Seesaw

NAT104



Posts and boards are made of pine wood from sustainable European sources. The wood is pressure impregnated Class 3 with Tanalith E3475 according to EN335 (Equivalent to NTR Class AB). On request it can be supplied as FSC® Certified (FSC® C004450).



The steel surfaces are hot dip galvanized inside and outside with lead free zinc. The galvanization has excellent corrosion resistance in outside environments and requires low maintenance.



The rocking movement is controlled by a heavy duty scaled rubber torsion spring element.

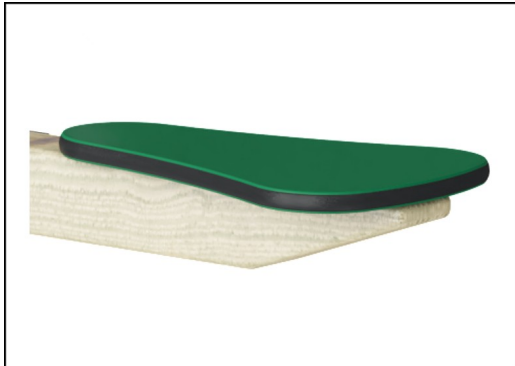

Panels of 19mm EcoCore™. EcoCore™ is a highly durable, eco friendly material, which is not only recyclable after use, but also consists of material produced from +95% recycled post consumer material from food packing waste.

Item no. NAT104-0712

Installation Information

Max. fall height	104 cm
Safety surfacing area	10.6 m ²
Total installation time	3.5
Excavation volume	0.48 m ³
Concrete volume	0.00 m ³
Footing depth (standard)	62 cm
Shipment weight	173 kg
Anchoring options	In-ground ✓ Surface ✓

Warranty Information

EcoCore HDPE	Lifetime
Hot dip galvanised steel	Lifetime
Pinewood	10 years
Rubber element	2 years
Spare parts guaranteed	10 years



Sustainability Data

NAT104



Cradle to Gate A1-A3	Total CO ₂ emission	CO ₂ e/kg	Recycled materials
	kg CO ₂ e	kg CO ₂ e/kg	%
NAT104-0712	140.57	1.09	19.32

The overall framework applied for these factors is the Environmental Product Declaration (EPD), which quantifies "environmental information on the life cycle of a product and enable comparisons between products fulfilling the same function" (ISO, 2006). This follows the structure and applies a Life-Cycle Assessment approach to the entire Product stage from raw material through manufacturing (A1-A3))

Kompan A/S
 C.F. Tietgens Boulevard 32C
 DK-5220 Odense SØ
 Denmark



Verification of CO₂ calculation of: Nature play



Data version no. 2023-10-05

The CO₂ calculation and data are in compliance with the principles of a carbon footprint impact according to the GHG protocol (Greenhouse Gas Protocol), Scope 3, cradle to gate related to all individual components in the product category: "Nature play" represented by item no.: NRO409-0621.

(Scope 3 emissions include emission sources in the upstream and downstream value chain).

Date: 30. October 2023 | Valid until: 30. October 2025

Verified by:

Julie Marie Vejsgaard Larsen, LCA & EPD Consultant

Verification based on report: Validation of CO₂ calculation of 9 categories of Kompan product line, version 1.0, prepared by: Bureau Veritas HSE, Denmark: Julie M. V. Larsen.

Publication date: 30. October 2023

By Bureau Veritas HSE
 www.bureauveritas.dk
 +45 7731 1000



Horse Ride Seesaw

NAT104

* Max fall height | ** Total height | *** Safety surfacing area

* Max fall height | ** Total height

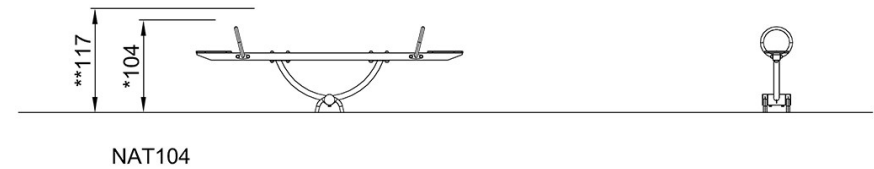
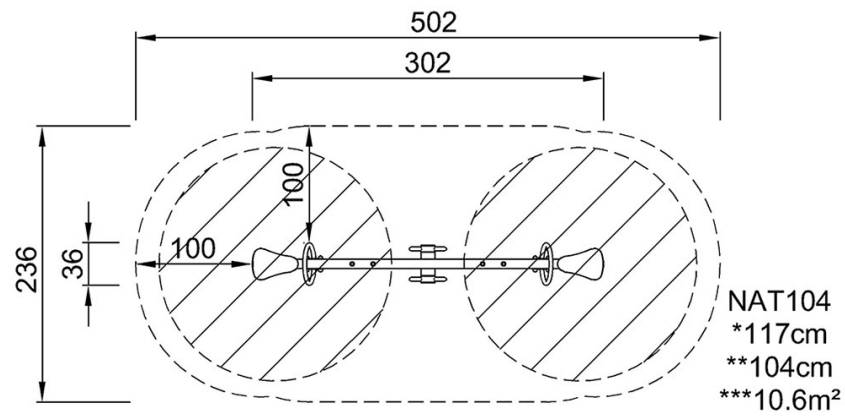

[Click to see TOP VIEW](#)

[Click to see SIDE VIEW](#)