

Water Lilies

M175

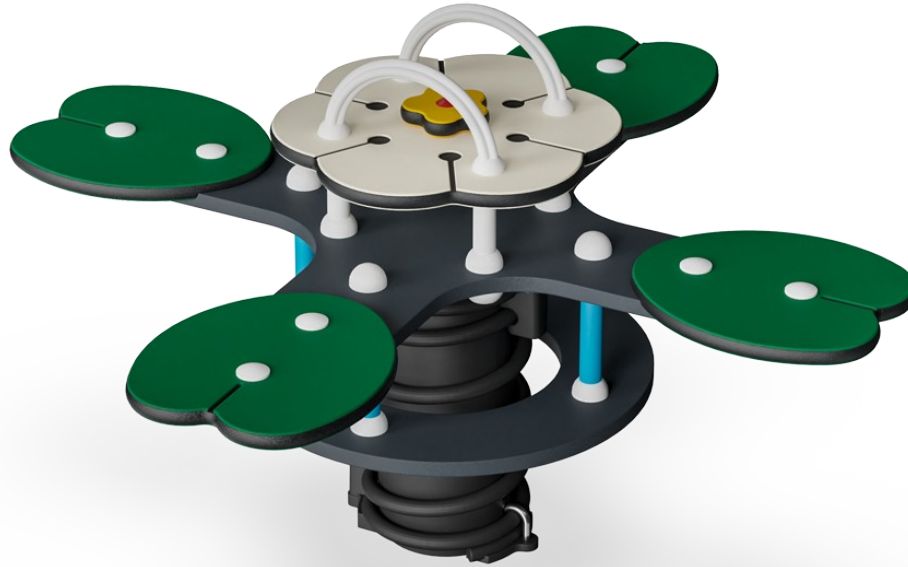

Item no. M17501-01P

General Product Information

| | |
|-----------------------|---|
| Dimensions LxWxH | 104x104x61 cm |
| Age group | 1+ |
| Play capacity (users) | 4 |
| Colour options |  |



WOW it's play time for toddlers. Under 5s will be thrilled by the social and physical potential of the Water Lilies: 1, 2, 3 or 4 children can seesaw, play and cooperate at the same time. This makes the Waterlilies a highly versatile play unit, taking up little space and appealing to toddlers again and again. Apart from being great play, the Water Lilies support

fundamental areas of childrens' development and learning through play: important motor skills such as balance and proprioception get trained when children rock, pushing their feet and pulling their arms. These are fundamental to life skills in later life. While rocking together, toddlers additionally train important social-emotional skills such as cooperation. The logic

of movement sequence trains the child's thinking skills. The Water Lilies are true playful learning.



Data is subject to change without prior notice.

Water Lilies

M175



Rocking together

Social-Emotional: the possibility of rocking two together trains cooperation skills and consideration of others.

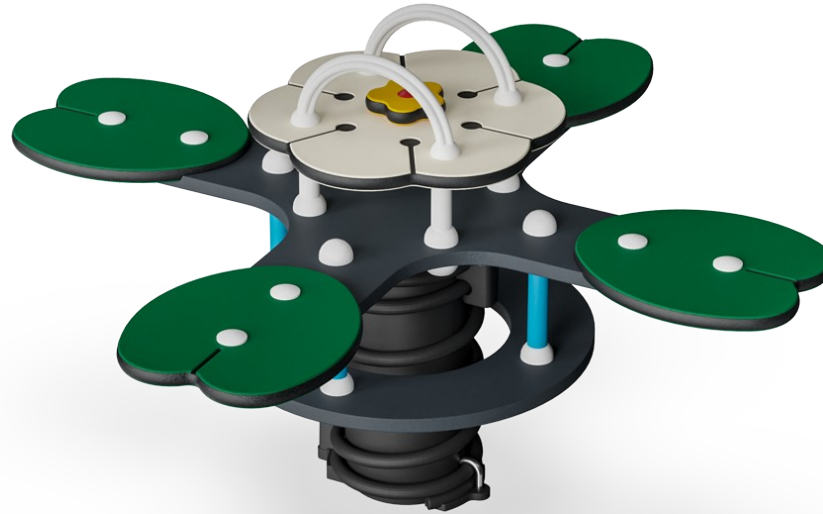

Handhold

Physical: opens more hold positions and ensures good grip, necessary for rocking intensely which trains hand and arm muscles.



Rocking spring

Physical: response to movements adds to spatial awareness and sense of balance which are fundamental motor skills.
Cognitive: trains the understanding of cause and effect: when I move my body, the spring responds with movement.



Foot support

Physical: the footrest supports intensive rocking, which stimulates the senses of balance and space, fundamental for managing the world securely.

Water Lilies

M175



Panels of 19mm EcoCore™. EcoCore™ is a highly durable, eco-friendly material, which is not only recyclable after use but also consists of a core produced from 100% recycled material.



KOMPAN's springs are manufactured from high-quality spring steel. The springs are cleaned by phosphating before being painted with epoxy primer and polyester powder coating. The springs are fixed by unique anti-pinch fittings for maximum safety and longevity.

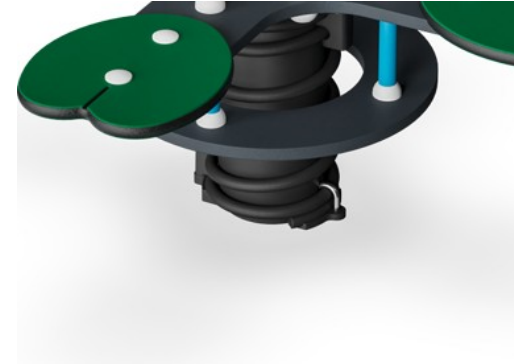

The springs are fixed by unique anti-pinch fittings for maximum safety and longevity.



Handholds are made of injection moulded high-quality nylon (PA6) which has good wearing and impact strength.

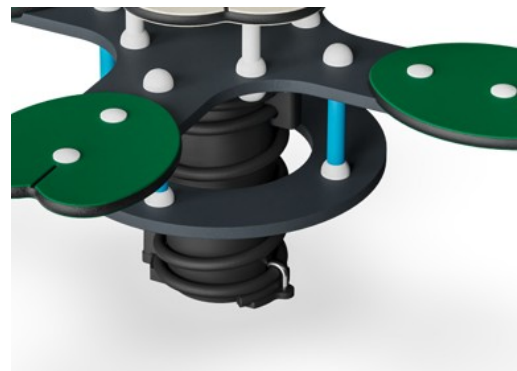

Foot support is made of HPL with a thickness of 17.8mm, which is very high wearing and also includes unique KOMPAN non-skid surface texture.



Steps are made of PUR which retains its properties in the temperature range of -30°C to 60°C making it a highly durable product without the use of heavy metal stabilisers.

| | |
|---------------------------------|--------------------------|
| Item no. M17501-01P | |
| Installation Information | |
| Max. fall height | 60 cm |
| Safety surfacing area | 9.6 m ² |
| Total installation time | 3.0 |
| Excavation volume | 0.19 m ³ |
| Concrete volume | 0.00 m ³ |
| Footing depth (standard) | 45 cm |
| Shipment weight | 54 kg |
| Anchoring options | In-ground ✓ Surface ✓ |
| Warranty Information | |
| EcoCore HDPE | Lifetime |
| HPL Decks | 15 years |
| Spare Parts Guarantee | 10 years |
| Springs | 5 years |



Sustainability Data

M175

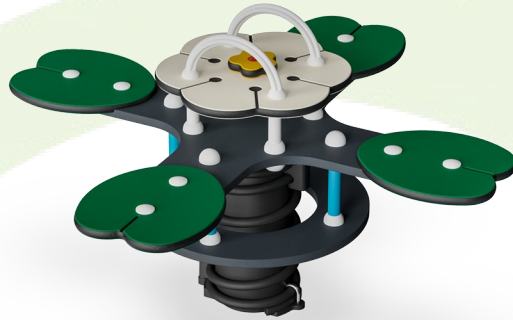

| Cradle to Gate A1-A3 | Total CO ₂ emission | CO ₂ e/kg | Recycled materials |
|----------------------|--------------------------------|-------------------------|--------------------|
| | kg CO ₂ e | kg CO ₂ e/kg | % |
| M17501-01P | 134.77 | 2.71 | 27.17 |

The overall framework applied for these factors is the Environmental Product Declaration (EPD), which quantifies "environmental information on the life cycle of a product and enable comparisons between products fulfilling the same function" (ISO, 2006). This follows the structure and applies a Life-Cycle Assessment approach to the entire Product stage from raw material through manufacturing (A1-A3))

Kompan A/S
C.F. Tietgens Boulevard 32C
DK-5220 Odense SØ
Denmark



Verification of CO₂ calculation of: Freestanding play equipment



Data version no. 2023-10-05

The CO₂ calculation and data are in compliance with the principles of a carbon footprint impact according to the GHG protocol (Greenhouse Gas Protocol), Scope 3, cradle to gate related to all individual components in the product category: "Freestanding play equipment" represented by item no.: GXY916012-3417.

(Scope 3 emissions include emission sources in the upstream and downstream value chain).

Date: 30. October 2023 | Valid until: 30. October 2025

Verified by:

Julie Marie Vejsgaard Larsen, LCA & EPD Consultant

Verification based on report: Validation of CO₂ calculation of 9 categories of Kompan product line, version 1.0, prepared by: Bureau Veritas HSE, Denmark: Julie M. V. Larsen.

Publication date: 30. October 2023

By Bureau Veritas HSE
www.bureauveritas.dk
+45 7731 1000



Water Lilies

M175

* Max fall height | ** Total height | *** Safety surfacing area

* Max fall height | ** Total height

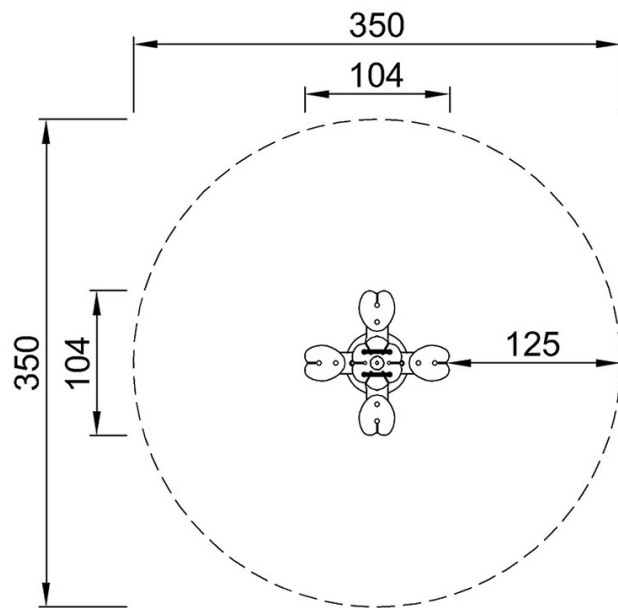

M17501
*60cm
**61cm
***9.6m²

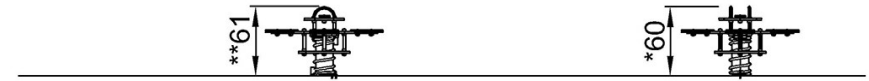

M17501

[Click to see TOP VIEW](#)

[Click to see SIDE VIEW](#)