

# Slide

M351



This is a slide for slightly older children who can experience that magical feeling in their stomachs as they rush down the slide chute. This KOMPAN item is almost 1.5 metres in height, which means that climbing up the steps poses a challenge in itself. However, this is not just for the brave and daring - the more careful youngsters will also feel confident playing on

this slide, as it is equipped with wide steps, openings in the sides that act as handgrips, and tall side panels with handholds at the top.

Item no. M35172-3418P	
<b>General Product Information</b>	
Dimensions LxWxH	50x325x210 cm
Age group	2+
Play capacity (users)	3
Colour options	

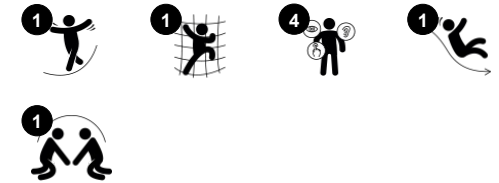

# Slide

M351



## Slide

**Physical:** sliding develops spatial awareness and a sense of balance. Furthermore, the core muscles are trained when sitting upright going down. **Social-Emotional:** empathy stimulated by turn-taking. **Cognitive:** young children develop their understanding of space, speed and distances when sliding down quickly.



## Stair ladder

**Physical:** cross coordination is used, supporting the cooperation of the left and right halves of the brain, which is necessary for reading. For young children, spatial awareness is trained when walking stairs.

# Slide

M351



Panels of 19mm EcoCore™. EcoCore™ is a highly durable, eco friendly material, which is not only recyclable after use, but also consists of material produced from +95% recycled post consumer material from food packing waste.



Steps are made of HPL with a thickness of 17,8mm with a very high wearing strength and a unique KOMPAN nonskid surface texture.



The stainless-steel slides with one-piece slide bed are made of high-quality stainless-steel AISI 304.

Item no. M35172-3418P

### Installation Information

Max. fall height	139 cm
Safety surfacing area	19.6 m <sup>2</sup>
Total installation time	6.0
Excavation volume	0.30 m <sup>3</sup>
Concrete volume	0.00 m <sup>3</sup>
Footing depth (standard)	62 cm
Shipment weight	262 kg
Anchoring options	In-ground ✓ Surface ✓

### Warranty Information

EcoCore HDPE	Lifetime
HPL decks	15 years
Spare parts guaranteed	10 years
Stainless steel slide	10 years

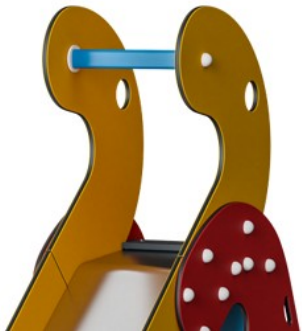

Handle is made of polypropylene PP with excellent impact strength and usable within a large temperature span.



KOMPAN GreenLine versions are designed with ultimate environmentally friendly materials with lowest possible CO2e emission factor such as EcoCore™ panels of +95% post consumer recycled ocean waste.



# Sustainability Data

M351



Cradle to Gate A1-A3	Total CO <sub>2</sub> emission	CO <sub>2</sub> e/kg	Recycled materials
	kg CO <sub>2</sub> e	kg CO <sub>2</sub> e/kg	%
<b>M35172-3418P</b>	254.92	1.48	76.05

The overall framework applied for these factors is the Environmental Product Declaration (EPD), which quantifies "environmental information on the life cycle of a product and enable comparisons between products fulfilling the same function" (ISO, 2006). This follows the structure and applies a Life-Cycle Assessment approach to the entire Product stage from raw material through manufacturing (A1-A3))

**Kompan A/S**  
C.F. Tietgens Boulevard 32C  
DK-5220 Odense SØ  
Denmark



## Verification of CO<sub>2</sub> calculation of: Freestanding play equipment



Data version no. 2023-10-05

The CO<sub>2</sub> calculation and data are in compliance with the principles of a carbon footprint impact according to the GHG protocol (Greenhouse Gas Protocol), Scope 3, cradle to gate related to all individual components in the product category: "Freestanding play equipment" represented by item no.: GXY916012-3417.

(Scope 3 emissions include emission sources in the upstream and downstream value chain).

**Date: 30. October 2023 | Valid until: 30. October 2025**

Verified by:

Julie Marie Vejsgaard Larsen, LCA & EPD Consultant

Verification based on report: Validation of CO<sub>2</sub> calculation of 9 categories of Kompan product line, version 1.0, prepared by: Bureau Veritas HSE, Denmark: Julie M. V. Larsen.

**Publication date: 30. October 2023**

By Bureau Veritas HSE  
www.bureauveritas.dk  
+45 7731 1000



# Slide

M351

\* Max fall height | \*\* Total height | \*\*\* Safety surfacing area

\* Max fall height | \*\* Total height

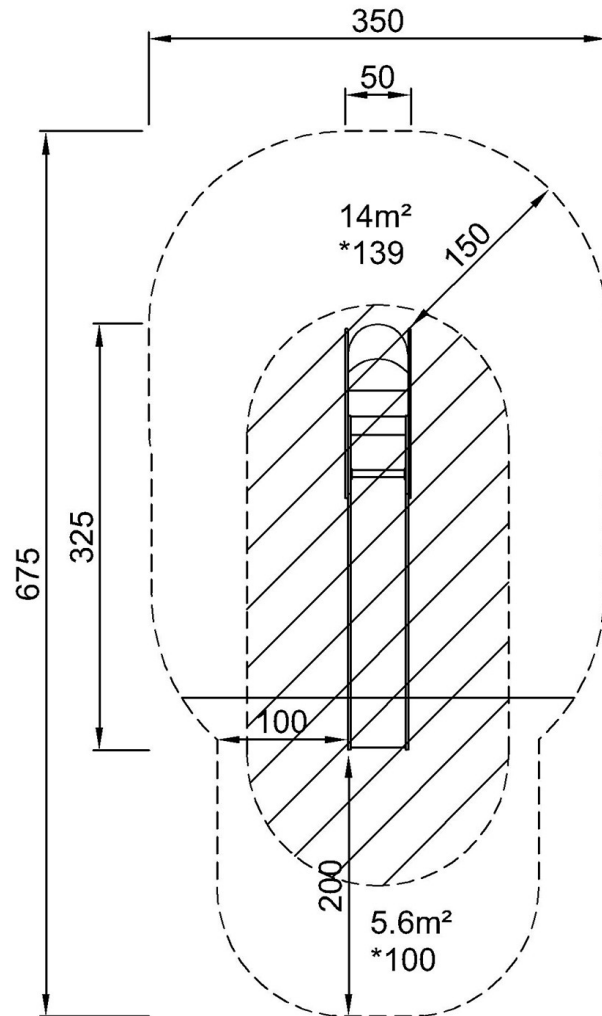

M35172  
\*139cm  
\*\*210cm  
\*\*\*19.6m<sup>2</sup>

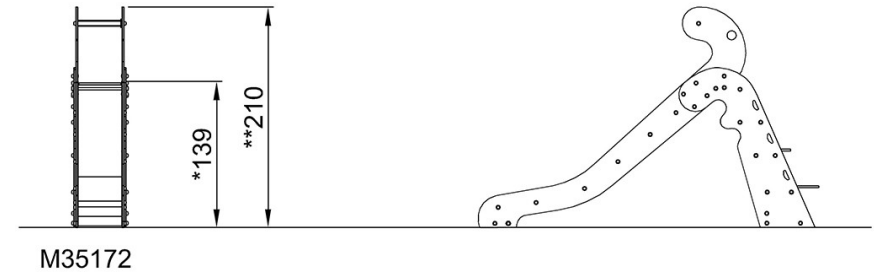

[Click to see TOP VIEW](#)

[Click to see SIDE VIEW](#)