

# Anita Table

PAR1052



Item no. PAR1052-0611

## General Product Information

Dimensions LxWxH 130x58x70 cm

Age group

Play capacity (users)

Color options



Outdoor Furniture plays an essential role in our communities by adding an inviting and social atmosphere, a place to meet, socialise or rest. Anita is classic and comfortable park furniture that invites citizens to take a seat and relax. They blend into and enhance public areas like parks and playgrounds etc. Anita Square Table is a freestanding table that can be combined

with Anita benches and chairs. Grouped furniture around a table offers countless possibilities for use.

# Anita Table

PAR1052



Boards are made of pine wood from sustainable European sources. The wood is pressure-impregnated according to EN335:2013, Class 3 (Equivalent to NTR Class AB). On request it can be supplied as FSC® Certified (FSC® C004450).



The steel surfaces are hot dip galvanized inside and outside with lead free zinc. The galvanization has excellent corrosion resistance in outdoor environments and require low maintenance. Painted steel parts are hot dip galvanized before powder coating.



Powder coated top finish on top of galvanisation is processed in two steps: Light grinding and clean sweeping, powder coating - thickness 70-120 µm.

Item no. PAR1052-0611

## Installation Information

|                          |                          |
|--------------------------|--------------------------|
| Total installation time  | 0.6                      |
| Excavation volume        | 0.12 m <sup>3</sup>      |
| Concrete volume          | 0.09 m <sup>3</sup>      |
| Footing depth (standard) | 65 cm                    |
| Shipment weight          | 26 kg                    |
| Anchoring options        | Surface ✓<br>In-ground ✓ |



KOMPAN outdoor furniture is available for surface and in-ground installation. Surface installation by anchoring to base layer or in-ground installation as either direct in ground or additional hot dip galvanized steel brackets.



The benches and tables can be combined in multiple settings by choosing individual products or assembled into larger solutions. See catalogue pages for more inspiration.

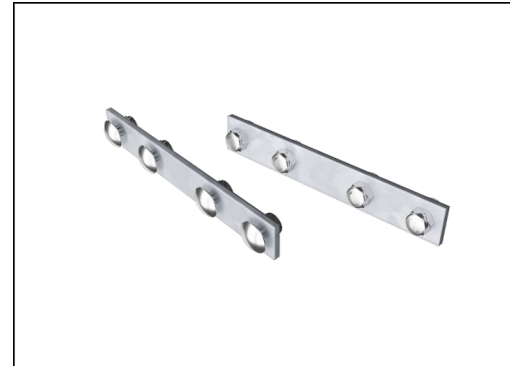

The hardware is made of stainless steel or galvanized steel to ensure durable connections with a high corrosion resistance.

# Sustainability Data

PAR1052



| Cradle to Gate A1-A3 | Total CO <sub>2</sub> emission | CO <sub>2</sub> e/kg    | Recycled materials |
|----------------------|--------------------------------|-------------------------|--------------------|
|                      | kg CO <sub>2</sub> e           | kg CO <sub>2</sub> e/kg | %                  |
| PAR1052-0611         | 37.81                          | 1.70                    | 31.64              |

The overall framework applied for these factors is the Environmental Product Declaration (EPD), which quantifies "environmental information on the life cycle of a product and enable comparisons between products fulfilling the same function" (ISO, 2006). This follows the structure and applies a Life-Cycle Assessment approach to the entire Product stage from raw material through manufacturing (A1-A3))

**Kompan A/S**  
 C.F. Tietgens Boulevard 32C  
 DK-5220 Odense SØ  
 Denmark



## Verification of CO<sub>2</sub> calculation of: Park



Data version no. 2023-10-05

The CO<sub>2</sub> calculation and data are in compliance with the principles of a carbon footprint impact according to the GHG protocol (Greenhouse Gas Protocol), Scope 3, cradle to gate related to all individual components in the product category: "Park" represented by item no.: PAR4070-0001.

(Scope 3 emissions include emission sources in the upstream and downstream value chain).

**Date: 30. October 2023 | Valid until: 30. October 2025**

**Verified by:**

Julie Marie Vejsgaard Larsen, LCA & EPD Consultant

Verification based on report: Validation of CO<sub>2</sub> calculation of 9 categories of Kompan product line, version 1.0, prepared by: Bureau Veritas HSE, Denmark: Julie M. V. Larsen.

**Publication date: 30. October 2023**

By Bureau Veritas HSE  
 www.bureauveritas.dk  
 +45 7731 1000

