

Toddlers Town

MSC5427

KOMPAN
Let's play



Item no. MSC542701-3418P

General Product Information

Dimensions LxWxH	244x61x140 cm
Age group	1+
Play capacity (users)	2
Colour options	

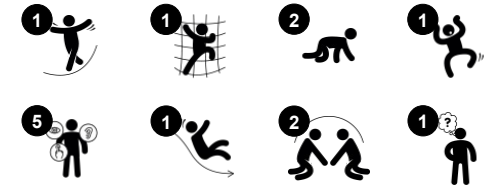

The Toddler's Town is a favorite play-ground activity that attracts children to being active and interactive in a thrilling way. The Toddler's Town offers a den under the slide platform, inviting meetings and socializing, the beginning of the first friendships. The stairway is wide and can be accessed crawling, too. This trains children's cross-coordination, an important

motor skill that among others support later reading skills. Sliding is a great thrill for the youngest. It additionally trains their core muscles, sitting upright while sliding down. Sliding trains the sense of balance and the spatial understanding, too. These skills are important in navigating the world securely. They are the fundament of all motor skills and

thus a fundament in physical confidence in the child. The house theme is familiar and inspires stories, developing language.



Toddlers Town

MSC5427



Slide

Physical: sliding develops spatial awareness and a sense of balance. Furthermore, the core muscles are trained when sitting upright going down. **Social-Emotional:** empathy stimulated by turn-taking. **Cognitive:** young children develop their understanding of space, speed and distances when sliding down quickly.



Den

Physical: crawling through the possible openings trains spatial awareness. **Social-Emotional:** the enclosed space invites social play for two or three children.



Stairway

Physical: climbing the stairs supports cross coordination as well as arm and leg muscles. **Social-Emotional:** room for active breaks and adult helpers.



Themed element

Cognitive: set a tangible theme and thus spur dramatic play. Dramatic play is a great trainer of language skills.

Toddlers Town

MSC5427



Panels of 19mm EcoCore™. EcoCore™ is a highly durable, eco friendly material, which is not only recyclable after use, but also consists of material produced from +95% recycled post consumer material from food packing waste.



All floors are made of High-Pressure Laminate HPL with a thickness 17.8mm and non skid surface texture according to EN 438-6. KOMPAN HPL has high wearing strength to ensure long lifetime in all climates.



The steel surfaces are hot dip galvanised inside and outside with lead free zinc. The galvanisation has excellent corrosion resistance in outside environments and requires low maintenance.

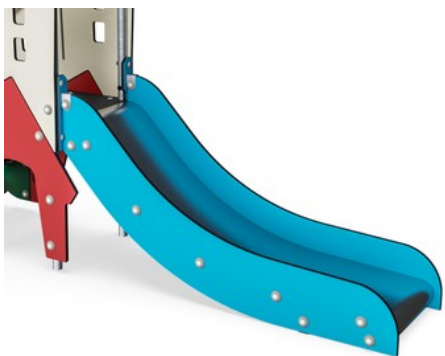

The slide bed can be chosen in different materials: Straight moulded PE or stainless steel slide bed t=2mm. Sides of the slides are made of EcoCore™.

Item no. MSC542701-3418P

Installation Information

Max. fall height	100 cm
Safety surfacing area	14.5 m ²
Total installation time	7.3
Excavation volume	0.17 m ³
Concrete volume	0.00 m ³
Footing depth (standard)	60 cm
Shipment weight	149 kg
Anchoring options	In-ground ✓ Surface ✓

Warranty Information

EcoCore HDPE	Lifetime
Hot dip galvanised steel	Lifetime
HPL decks	15 years
Spare parts guaranteed	10 years



Sustainability Data

MSC5427

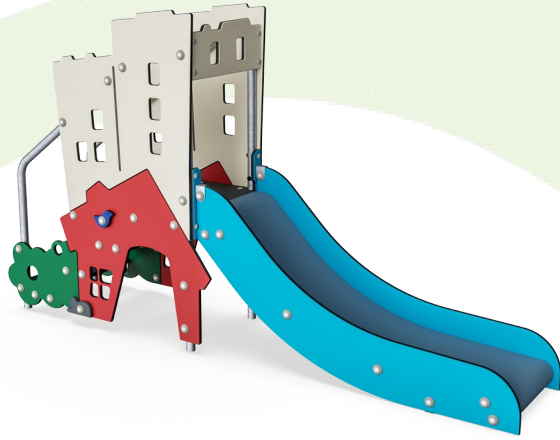

Cradle to Gate A1-A3	Total CO ₂ emission	CO ₂ e/kg	Recycled materials
	kg CO ₂ e	kg CO ₂ e/kg	%
MSC542701-3418P	177.50	1.87	62.45

The overall framework applied for these factors is the Environmental Product Declaration (EPD), which quantifies "environmental information on the life cycle of a product and enable comparisons between products fulfilling the same function" (ISO, 2006). This follows the structure and applies a Life-Cycle Assessment approach to the entire Product stage from raw material through manufacturing (A1-A3))

Kompan A/S
 C.F. Tietgens Boulevard 32C
 DK-5220 Odense SØ
 Denmark



Verification of CO₂ calculation of: Themed play systems



Data version no. 2023-10-05

The CO₂ calculation and data are in compliance with the principles of a carbon footprint impact according to the GHG protocol (Greenhouse Gas Protocol), Scope 3, cradle to gate related to all individual components in the product category: "Themed play systems" represented by item no.: MSC641100-3717P.

(Scope 3 emissions include emission sources in the upstream and downstream value chain).

Date: 30. October 2023 | Valid until: 30. October 2025

Verified by:

Julie Marie Vejsgaard Larsen, LCA & EPD Consultant

Verification based on report: Validation of CO₂ calculation of 9 categories of Kompan product line, version 1.0, prepared by: Bureau Veritas HSE, Denmark: Julie M. V. Larsen.

Publication date: 30. October 2023

By Bureau Veritas HSE
 www.bureauveritas.dk
 +45 7731 1000



Toddlers Town

MSC5427

* Max fall height | ** Total height | *** Safety surfacing area

* Max fall height | ** Total height

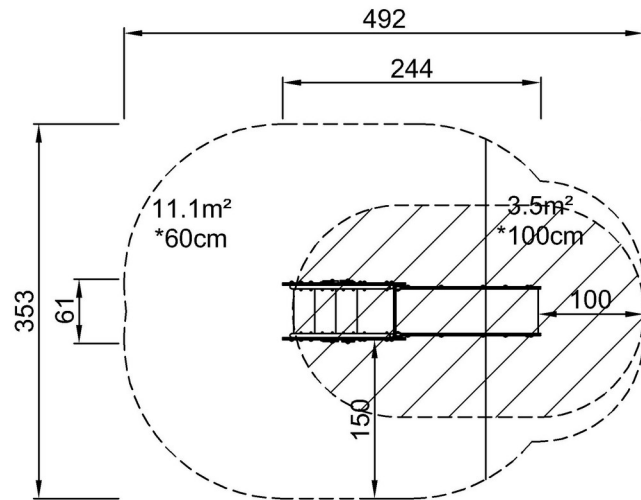

MSC542701
*100cm
**140cm
***14.5m²

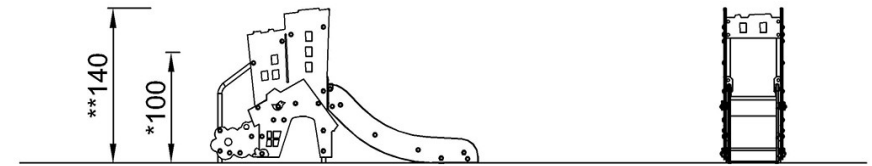

MSC542701

[Click to see TOP VIEW](#)

[Click to see SIDE VIEW](#)