

Caravelle

PCM102521



Item no. PCM102521-0901	
General Product Information	
Dimensions LxWxH	565x170x441 cm
Age group	2+
Play capacity (users)	13
Color options	



The exciting Caravelle offers multiple play opportunities. It will inspire dramatic and active play, supporting the development of children's muscles as well as their social and cognitive play skills. This is essential for early development, in particular of language. Carefully designed play elements such as the steering wheel encourage exploration and

dramatic play, stimulating logical thinking and language skills. The boarding net provides a physical challenge, stimulating cross-coordination and proprioception, important for the child's feeling of security in the world. The slide down is the reward. The hammock at ground level extends the play with its swaying play invitation, stimulating the sense of

balance.



Caravelle

PCM102521



Panels of 19mm EcoCore™. EcoCore™ is a highly durable, eco friendly material, which is not only recyclable after use, but also consists of material produced from +95% recycled post consumer material from food packing waste.



Main posts with hot dip galvanised steel footing are available in different materials: Pressure impregnated pine wood posts. Pre-galvanised inside and outside with powder coated top finish steel posts. Lead free aluminium with colour anodised top finish.



All decks are supported by unique designed low-carbon aluminum profiles with multiple attachment options. The grey colored molded decks are made of 75% post-consumer waste PP material with a non-skid pattern and texture surface.

Item no. PCM102521-0901

Installation Information

Max. fall height	118 cm
Safety surfacing area	29.8 m ²
Total installation time	15.1
Excavation volume	0.77 m ³
Concrete volume	0.13 m ³
Footing depth (standard)	90 cm
Shipment weight	469 kg
Anchoring options	In-ground ✓ Surface ✓



The slides can be chosen in different materials and colours: Straight or curved moulded PE slides in yellow or grey colour. Full stainless steel in on-piece design for more vandalism proof solutions.



Nets and ropes are made of UV-stabilised PA with inner steel cable reinforcement. The rope is induction treated in order to create a strong connection between steel and rope which leads to good wear resistance.



KOMPAN Play Systems can be customised to match individual demands. Visit the products at www.KOMPAN.com for options with the digital KOMPAN Solution Planner. Multiple options for panels, decks, posts, slides and other play activities ensure durable solutions in any outdoor environment.



Sustainability Data

PCM102521



Cradle to Gate A1-A3	Total CO ₂ emission	CO ₂ e/kg	Recycled materials
	kg CO ₂ e	kg CO ₂ e/kg	%
PCM102521-0901	762.80	2.24	60.80

The overall framework applied for these factors is the Environmental Product Declaration (EPD), which quantifies "environmental information on the life cycle of a product and enable comparisons between products fulfilling the same function" (ISO, 2006). This follows the structure and applies a Life-Cycle Assessment approach to the entire Product stage from raw material through manufacturing (A1-A3))

Kompan A/S
 C.F. Tietgens Boulevard 32C
 DK-5220 Odense SØ
 Denmark



Verification of CO₂ calculation of: Play systems



Data version no. 2023-10-05

The CO₂ calculation and data are in compliance with the principles of a carbon footprint impact according to the GHG protocol (Greenhouse Gas Protocol), Scope 3, cradle to gate related to all individual components in the product category: "Play systems" represented by item no.: PCM200321-0950.

(Scope 3 emissions include emission sources in the upstream and downstream value chain).

Date: 30. October 2023 | Valid until: 30. October 2025

Verified by:

Julie Marie Vejsgaard Larsen, LCA & EPD Consultant

Verification based on report: Validation of CO₂ calculation of 9 categories of Kompan product line, version 1.0, prepared by: Bureau Veritas HSE, Denmark: Julie M. V. Larsen.

Publication date: 30. October 2023

By Bureau Veritas HSE
 www.bureauveritas.dk
 +45 7731 1000



Caravelle

PCM102521

* Max fall height | ** Total height | *** Safety surfacing area

* Max fall height | ** Total height

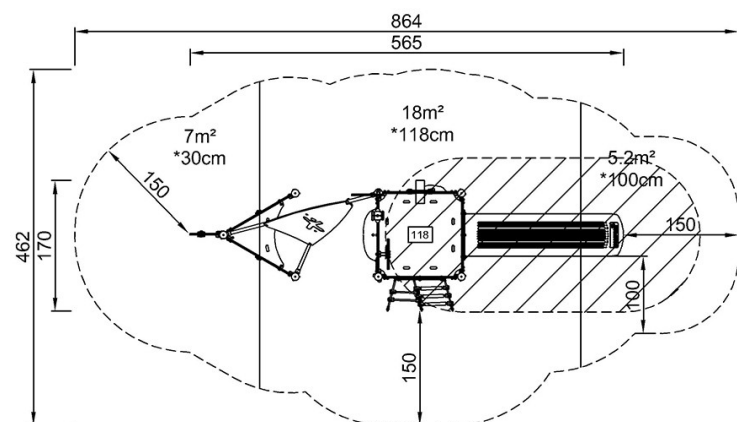

PCM102521
*118cm
**441cm
***29.8m²

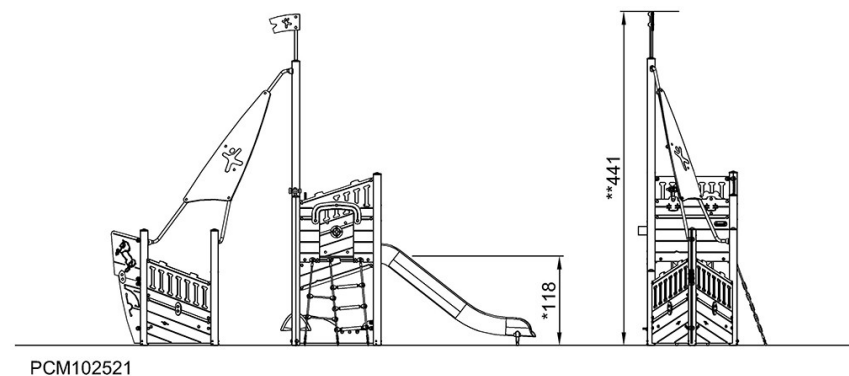

[Click to see TOP VIEW](#)

[Click to see SIDE VIEW](#)