

Ice Cream Cart

PCM52431



Item no. PCM52431-0901

General Product Information

Dimensions LxWxH	9'2"x3'11"x6'2"
Age group	2 - 5
Play capacity (users)	9
Color options	



The sweet Ice Cream Cart inspires the most popular make-believe play of all: Trading and playing shop. The richness of themed and tactile, moving play elements support dramatic play and conversations. They spur cooperation, thus paving the way for social understanding and friendships. When children explore the functionality of for instance the rubber flaps and

put items through the holes in the desk, or when they run the flowers in the grooves of the flower bush, it is not solely great explorative play. It also trains children's understanding of cause-and-effect, their understanding of object permanence and their logical thinking skills. The dramatic play scenarios, playing ice cart, trains communication and language skills.



Ice Cream Cart

PCM52431



Bench
Social-Emotional: invites socializing and cooperation. Allows for a break with friends.



Abacus
Cognitive: supports understanding of measurement.

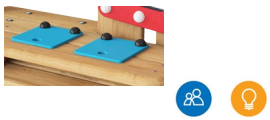

Desk flaps w. holes
Social-Emotional: cooperation, turn-taking and parallel play inspired by the two flaps.
Cognitive: shifting things through holes to shelf supports logical thinking and the understanding of object permanence.



Theme
Cognitive: suggests a theme and supports dramatic play, which stimulates language and communication skills.

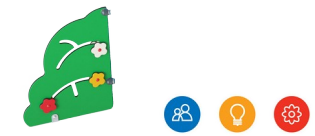

Flower panel
Social-Emotional: invites cooperation due to the two-sidedness. **Cognitive:** the tangible theme stimulates language and communication skills. **Creative:** children can leave their mark, placing the flowers in different positions.



Desk
Social-Emotional: fine meeting place and a space creator. Sharing and cooperation from both sides create a social scenario that supports communication and cooperation.

Ice Cream Cart

PCM52431



Panels of 19mm EcoCore™. EcoCore™ is a highly durable, eco friendly material, which is not only recyclable after use, but also consists of a core produced from 100% recycled material.



Main posts with hot dip galvanized steel footing are available in different materials: Pre-galvanized inside and outside with powder coated top finish steel posts. Lead free aluminum with color anodized top finish. TexMade posts of 95% post-consumer recycled PE and textile waste.



The steel surfaces are hot-dip galvanized inside and outside with lead-free zinc. The galvanization has excellent corrosion resistance in outside environments and requires minimal maintenance.

Item no. PCM52431-0901

Installation Information

Max. fall height	0'0"
Safety surfacing area	0ft²
Total installation time	8.3
Excavation volume	0.21yd³
Concrete volume	0yd³
Footing depth (standard)	2'11"
Shipment weight	331lbs
Anchoring options	Surface ✓ In-ground ✓

Warranty Information

EcoCore HDPE	Lifetime
Hot dip galvanized steel	Lifetime
Post	10 Years
Spare Parts Availability	10 Years

Elevated activities	Accessible elevated activities	Accessible ground level activities	Accessible ground level play types
Present			
Required			

Sustainability Data

PCM52431



Cradle to Gate A1-A3	Total CO ₂ emission	CO ₂ e/kg	Recycled materials
	kg CO ₂ e	kg CO ₂ e/kg	%
PCM52431-0901	173.33	1.55	77.35

The overall framework applied for these factors is the Environmental Product Declaration (EPD), which quantifies "environmental information on the life cycle of a product and enable comparisons between products fulfilling the same function" (ISO, 2006). This follows the structure and applies a Life-Cycle Assessment approach to the entire Product stage from raw material through manufacturing (A1-A3))

Kompan A/S
 C.F. Tietgens Boulevard 32C
 DK-5220 Odense SØ
 Denmark



Verification of CO₂ calculation of: Play systems



Data version no. 2023-10-05

The CO₂ calculation and data are in compliance with the principles of a carbon footprint impact according to the GHG protocol (Greenhouse Gas Protocol), Scope 3, cradle to gate related to all individual components in the product category: "Play systems" represented by item no.: PCM200321-0950.

(Scope 3 emissions include emission sources in the upstream and downstream value chain).

Date: 30. October 2023 | Valid until: 30. October 2025

Verified by:

Julie Marie Vejsgaard Larsen, LCA & EPD Consultant

Verification based on report: Validation of CO₂ calculation of 9 categories of Kompan product line, version 1.0, prepared by: Bureau Veritas HSE, Denmark: Julie M. V. Larsen.

Publication date: 30. October 2023

By Bureau Veritas HSE
 www.bureauveritas.dk
 +45 7731 1000



Ice Cream Cart

PCM52431

* Max fall height | ** Total height | *** Safety surfacing area

* Max fall height | ** Total height

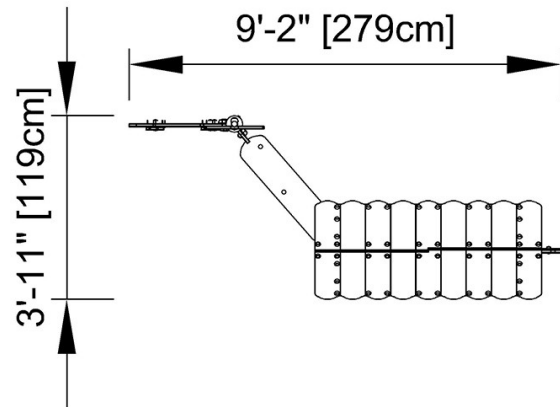

PCM52431
* 0'-0" / 0cm
** 6'-2" / 187cm
*** 0ft² / 0m²

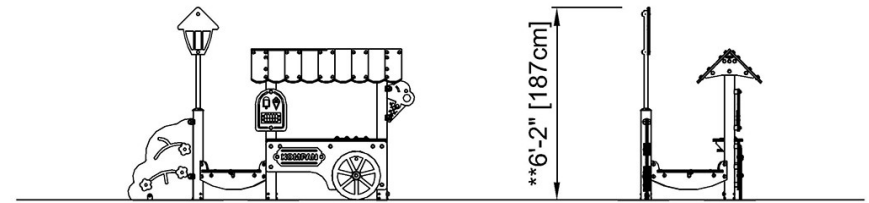

PCM52431

[Click to see TOP VIEW](#)

[Click to see SIDE VIEW](#)