

Climbing Structure

NRO818



Item no. NRO818-1001

General Product Information

Dimensions LxWxH	444x173x255 cm
Age group	6+
Play capacity (users)	7
Colour options	

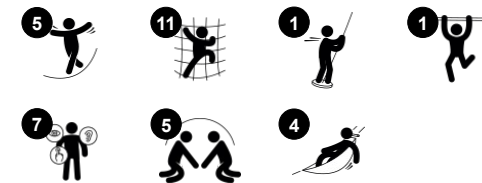

The product is available as FSC® Certified (FSC® C004450) robinia wood on request.

Climbing Structure

NRO818



Climbing grips

Physical: dexterity and cross-body coordination, sense of space, all important in navigating the body in space. Pushing, pulling and using fingers, arms, legs and core, strengthen the muscles.



Parkour ropes

Physical: the big rubbery discs are great support for the feet when climbing or crossing. This trains cross coordination, balance and arm and leg muscles. This combination adds to the child's body adeptness and awareness, adding security to movements. **Social-Emotional:** the seats make a nice destination and meeting point and take cooperation when crossing by others on the way through the module.



Banister bars

Physical: coordination is supported when going down, as well as arm and core muscles. Landing strengthens bone density, which is built for life in childhood. **Social-Emotional:** turn-taking and risk-taking.



Rope ladder

Physical: cross coordination is supported when children climb the ladder. The climbing also trains leg and arm muscles. **Social-Emotional:** place for meeting, taking a break and socializing.

Climbing Structure

NRO818



All Organic Robinia products by KOMPAN are made of Robinia wood from sustainable European sources. On request it can be supplied as FSC® Certified (FSC® C004450).



Full coloured EPDM rubber seats with smooth surface. The seats are moulded on a hot dip galvanised steel inlay that ensures durable fixation to the rope.



Plywood climbing panel. The climbing panels are made of 21,5mm thick plywood made from alder and pine wood. Both sides are covered by 2 layers of phenolic film with anti slip net pattern. All cutting edges are sealed with paint to ensure long lifetime.



Ropes of UV-stabilized PES rope strands with inner steel cable reinforcement. The polyester yarn is made of +95% Post-consumer materials and is inductively melted onto each strand to obtain excellent wear and tear resistance.



The Robinia wood can be supplied as untreated raw wood or painted with a brown coloured transparent pigment that maintains the golden wood colour of the wood.

Item no. NRO818-1001	
Installation Information	
Max. fall height	250 cm
Safety surfacing area	36.7 m ²
Total installation time	11.5
Excavation volume	2.13 m ³
Concrete volume	0.10 m ³
Footing depth (standard)	100 cm
Shipment weight	532 kg
Anchoring options	In-ground ✓
Warranty Information	
EPDM components	2 years
Plywood	5 years
Robinia wood	15 years
Ropes & nets	10 years
Spare parts guaranteed	10 years



Sustainability Data

NRO818

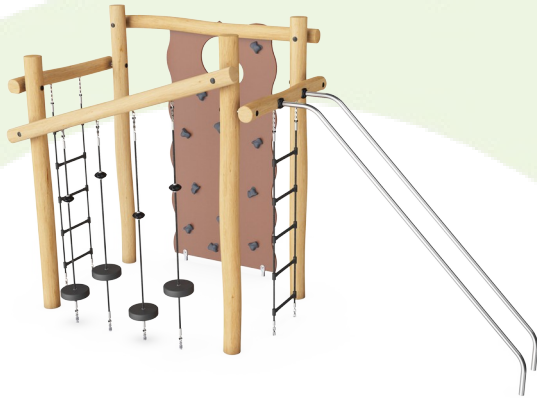

Cradle to Gate A1-A3	Total CO ₂ emission	CO ₂ e/kg	Recycled materials
	kg CO ₂ e	kg CO ₂ e/kg	%
NRO818-1001	300.18	0.68	7.29

The overall framework applied for these factors is the Environmental Product Declaration (EPD), which quantifies "environmental information on the life cycle of a product and enable comparisons between products fulfilling the same function" (ISO, 2006). This follows the structure and applies a Life-Cycle Assessment approach to the entire Product stage from raw material through manufacturing (A1-A3))

Kompan A/S
 C.F. Tietgens Boulevard 32C
 DK-5220 Odense SØ
 Denmark



Verification of CO₂ calculation of: Nature play



Data version no. 2023-10-05

The CO₂ calculation and data are in compliance with the principles of a carbon footprint impact according to the GHG protocol (Greenhouse Gas Protocol), Scope 3, cradle to gate related to all individual components in the product category: "Nature play" represented by item no.: NRO409-0621.

(Scope 3 emissions include emission sources in the upstream and downstream value chain).

Date: 30. October 2023 | Valid until: 30. October 2025

Verified by:

Julie Marie Vejsgaard Larsen, LCA & EPD Consultant

Verification based on report: Validation of CO₂ calculation of 9 categories of Kompan product line, version 1.0, prepared by: Bureau Veritas HSE, Denmark: Julie M. V. Larsen.

Publication date: 30. October 2023

By Bureau Veritas HSE
 www.bureauveritas.dk
 +45 7731 1000



Climbing Structure

NRO818

* Max fall height | ** Total height | *** Safety surfacing area

* Max fall height | ** Total height

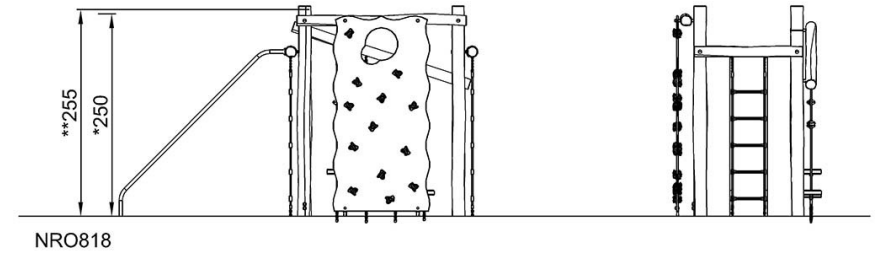
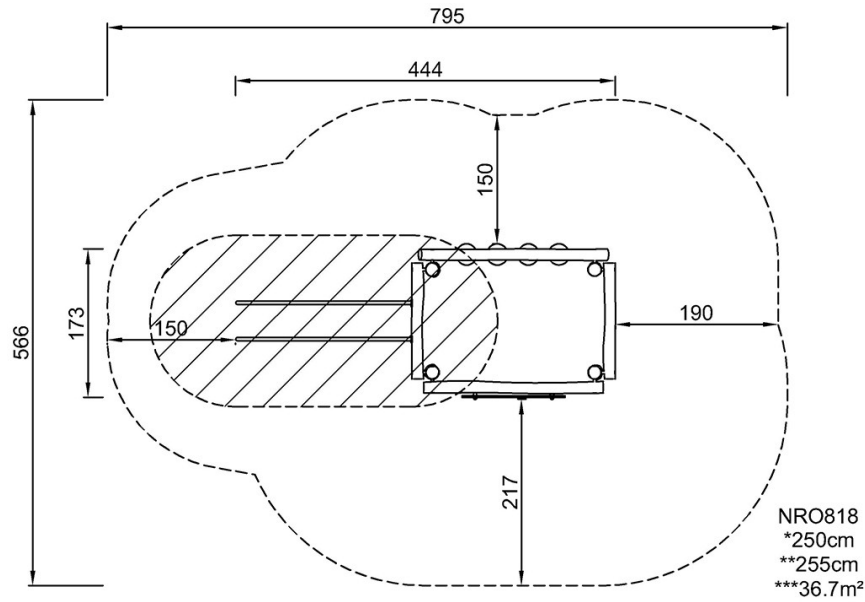

[Click to see TOP VIEW](#)

[Click to see SIDE VIEW](#)