

Crosstrainer

FSW239

KOMPAN
Let's play



The Cross Trainer appeals to a wide demographic due to its low-impact design that incorporates both upper and lower body movement. Ergonomically optimized, it provides a comfortable exercise that's easy on the joints. Workload is adjustable with 10 resistance levels, controlled by a handle reachable from the standing position. The

smooth magnetic brake system caters to all training intensities, suitable for rehabilitation or athletic conditioning. It also features a phone holder for multimedia entertainment during workouts.

Item nummer FSW23900-0001	
Algemene Product Informatie	
Afmetingen LxBxH	165x70x167 cm
Leeftijdsgroep	13+
Speelcapaciteit	1
Kleuropties	



Meer op KOMPAN Fit app



Crosstrainer

FSW239



De crosstrainer heeft een gelast stalen frame dat de voorkant en de achterkant van het toestel met elkaar verbindt. Het frame creëert een extreem sterke en stabiele constructie die nodig is om de hoge krachten die worden uitgeoefend op te vangen.

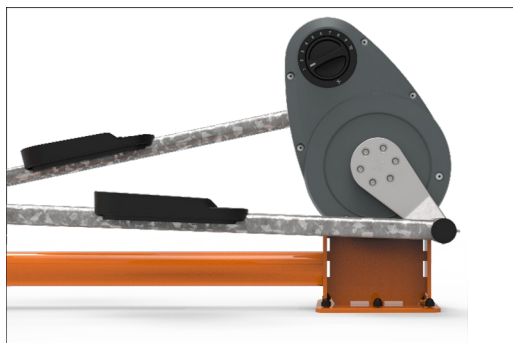

De weerstandsunit en alle mechanische onderdelen zitten in een volledig gesloten kast gemaakt van UV-gestabiliseerd polycarbonaat (PC). Dit voorkomt beknelling en maakt het toestel extreem veilig in gebruik. Daarnaast biedt de kast bescherming tegen weersinvloeden.

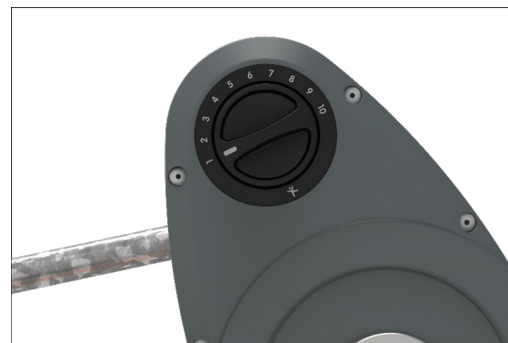

Het magnetisch weerstandssysteem is volledig bedekt en instelbaar met een draaiknop in 10 stappen. Het systeem is intuïtief in gebruik: je draait aan de knop om de weerstand te verhogen of verlagen.



The machine is equipped with a weighted flywheel that ensures that the motion stays fluid and comfortable during use.

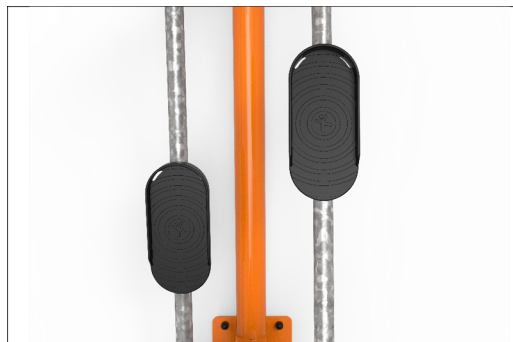

The footplates are made from molded pp and secured to the cross trainer using 4 threaded inserts and accommodates most foot sizes.



The center console of has a phone holder made from s235 steel with a thickness of 6mm.

Item nummer FSW23900-0001

Installatie informatie

Max. valhoogte	50 cm
Veiligheidszone	15,3 m ²
Totale installatietijd	3,3
Graafwerk (vol.)	0,00 m ³
Benodigd beton	0,00 m ³
Verankeringsdiepte	0 cm
Verzendingsgewicht	170 kg
Verankeringsopties	Oppervlak ✓

Garantie informatie

Aluminum	15 jaar
EcoCore HDPE	Levenslang
Bewegende delen	2 jaar
Gegarandeerde reserveonderdelen	10 jaar
Stalen frame	10 jaar

EN
16630
compliant

Sustainability Data

FSW239



Cradle to Gate A1-A3	Total CO ₂ emission	CO ₂ e/kg	Recycled materials
	kg CO ₂ e	kg CO ₂ e/kg	%
FSW23900-0001	337,45	3,06	45,74

The overall framework applied for these factors is the Environmental Product Declaration (EPD), which quantifies "environmental information on the life cycle of a product and enable comparisons between products fulfilling the same function" (ISO, 2006). This follows the structure and applies a Life-Cycle Assessment approach to the entire Product stage from raw material through manufacturing (A1-A3))

Kompan A/S
C.F. Tietgens Boulevard 32C
DK-5220 Odense SØ
Denmark



Verification of CO₂ calculation of: Fitness



Data version no. 2023-10-05

The CO₂ calculation and data are in compliance with the principles of a carbon footprint impact according to the GHG protocol (Greenhouse Gas Protocol), Scope 3, cradle to gate related to all individual components in the product category: "Fitness" represented by item no.: FAZ10100-0900.

(Scope 3 emissions include emission sources in the upstream and downstream value chain).

Date: 30. October 2023 | Valid until: 30. October 2025

Verified by:

Julie Marie Vejsgaard Larsen, LCA & EPD Consultant

Verification based on report: Validation of CO₂ calculation of 9 categories of Kompan product line, version 1.0, prepared by: Bureau Veritas HSE, Denmark: Julie M. V. Larsen.

Publication date: 30. October 2023

By Bureau Veritas HSE
www.bureauveritas.dk
+45 7731 1000



Crosstrainer

FSW239

Max. valhoogte | Totale Hoogte | Veiligheidszone

Max. valhoogte | Totale Hoogte

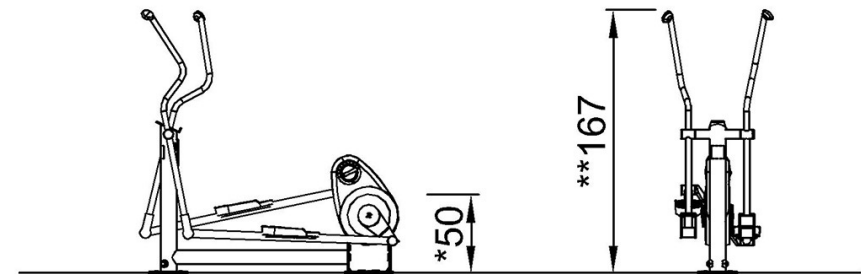
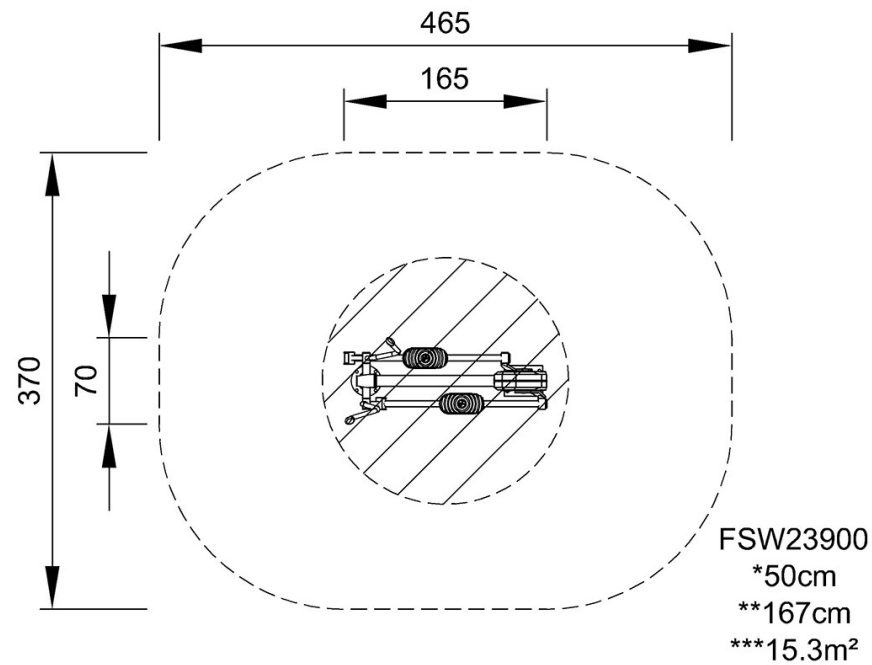

FSW23900

[Bekijk BOVENAANZICHT](#)

[Bekijk ZIJAANZICHT](#)