

# Sky Carousel

PCM151



Item no. PCM151-0901

## General Product Information

Dimensions LxWxH	113x113x182 cm
Age group	6+
Play capacity (users)	6
Colour options	  

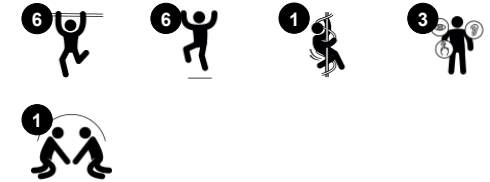

The Sky Carousel is a playground hit that attracts school age children again and again. It adds thrill and fun. It also helps to strengthen muscles when hanging in arms and jumping on. It supports bone density when children jump off. The physical benefits are immense, as the rotation combined with the jumping off trains the senses of balance and space

immensely. These are the fundament of physical confidence. They help children to for instance sit still and concentrate. They help them manage and time their body movements securely in space, for instance when crossing a street. The two levels and steps support children of different sizes to access the spinning experience. The rings provide high

play capacity, which in turn spurs rough-and-tumble play and cooperation. This adds a huge social-emotional benefit for children.

# Sky Carousel

PCM151



## Vertical bar

**Physical:** pushing or pulling the Sky carousel into motion, children use their muscle strength and strengthen their cardio. **Social-Emotional:** listening and negotiating if someone wants to get off, children develop their empathy and cooperation skills.



## Foot support

**Social-Emotional:** invites a wide user range and provides an ease of entry for smaller or less confident users.



## Upper and lower handhold

**Physical:** balance, spatial awareness and coordination are developed when spinning around, as well as arm and core muscles when holding tight. Jumping off strengthens bone density, which is built for life in early childhood. **Social-Emotional:** turn-taking, cooperation and empathy are trained when many children are spinning together.

# Sky Carousel

PCM151



The upper twin ring has a base of hot dip galvanisation and a powder coated top finish. This provides an ultimate corrosion resistance in all climates around the world.



Steps are made of PUR. It retains their properties in the temperature range of -30°C to 60°C. Step is stabilised to a maximum without use of heavy metal stabilities.



Heavy duty engineered bearing system with single row deep groove ball bearings with rubber seals. The fully closed bearing construction is lifetime lubricated and maintenance free.



The steel surfaces are hot dip galvanised inside and outside with lead free zinc. The galvanisation has excellent corrosion resistance in outside environments and requires low maintenance.

Item no. PCM151-0901	
Installation Information	
Max. fall height	172 cm
Safety surfacing area	40.0 m <sup>2</sup>
Total installation time	2.7
Excavation volume	0.50 m <sup>3</sup>
Concrete volume	0.29 m <sup>3</sup>
Footing depth (standard)	100 cm
Shipment weight	136 kg
Anchoring options	In-ground ✓ Surface ✓
Warranty Information	
Bearing construction	5 years
Hot dip galvanised steel	Lifetime
Painted toplayer	10 years
Spare parts guaranteed	10 years



# Sustainability Data

PCM151



Cradle to Gate A1-A3	Total CO <sub>2</sub> emission	CO <sub>2</sub> e/kg	Recycled materials
	kg CO <sub>2</sub> e	kg CO <sub>2</sub> e/kg	%
<b>PCM151-0901</b>	293.49	3.09	44.40

The overall framework applied for these factors is the Environmental Product Declaration (EPD), which quantifies "environmental information on the life cycle of a product and enable comparisons between products fulfilling the same function" (ISO, 2006). This follows the structure and applies a Life-Cycle Assessment approach to the entire Product stage from raw material through manufacturing (A1-A3))

**Kompan A/S**  
 C.F. Tietgens Boulevard 32C  
 DK-5220 Odense SØ  
 Denmark



## Verification of CO<sub>2</sub> calculation of: Freestanding play equipment



Data version no. 2023-10-05

The CO<sub>2</sub> calculation and data are in compliance with the principles of a carbon footprint impact according to the GHG protocol (Greenhouse Gas Protocol), Scope 3, cradle to gate related to all individual components in the product category: "Freestanding play equipment" represented by item no.: GXY916012-3417.

(Scope 3 emissions include emission sources in the upstream and downstream value chain).

**Date: 30. October 2023 | Valid until: 30. October 2025**

**Verified by:**

Julie Marie Vejsgaard Larsen, LCA & EPD Consultant

Verification based on report: Validation of CO<sub>2</sub> calculation of 9 categories of Kompan product line, version 1.0, prepared by: Bureau Veritas HSE, Denmark: Julie M. V. Larsen.

**Publication date: 30. October 2023**

**By Bureau Veritas HSE**  
 www.bureauveritas.dk  
 +45 7731 1000



# Sky Carousel

PCM151

\* Max fall height | \*\* Total height | \*\*\* Safety surfacing area

\* Max fall height | \*\* Total height

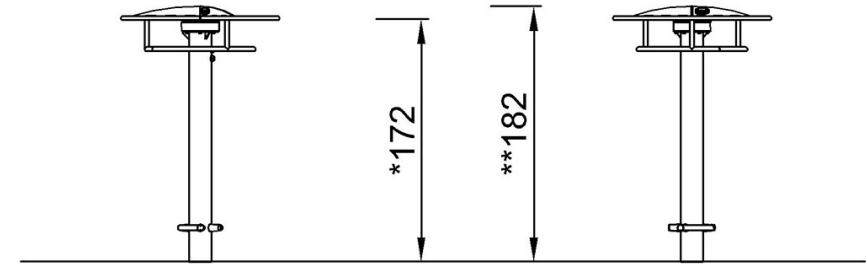
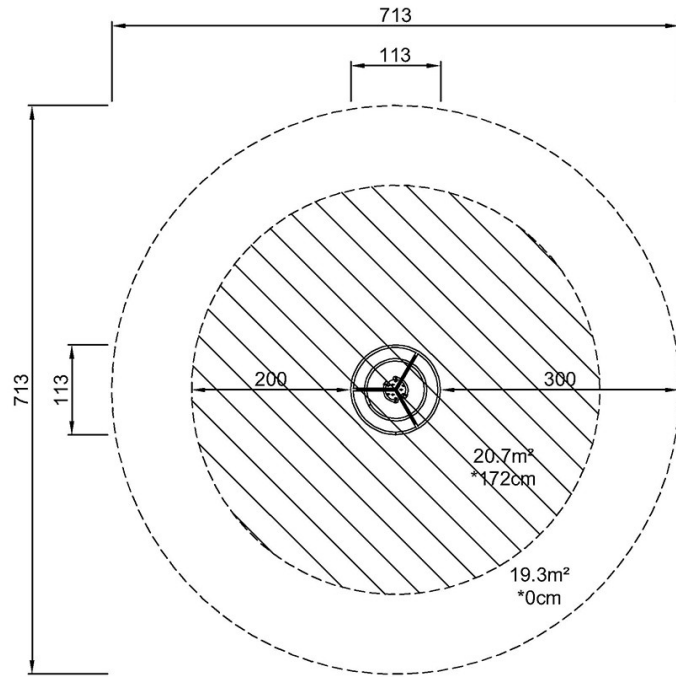

PCM151

PCM151  
\*172cm  
\*\*182cm  
\*\*\*40m<sup>2</sup>

[Click to see TOP VIEW](#)

[Click to see SIDE VIEW](#)