

# Outdoor Play Timer

PCM201



Item no. PCM201-0901	
<b>General Product Information</b>	
Dimensions LxWxH	1'5"x0'9"x4'2"
Age group	5 - 12
Play capacity (users)	4
Color options	●



The Play Timer attracts children of all ages immensely with its count-down sounds and its timer push-buttons. The mere fact that you can measure your efforts and measure them up against your friends' is a play asset that makes children use the Play Timer over and over, and return for more. In the development of the Play Timer, KOMPAN built on KOMPAN Play

Institute research of thrilling play stating that racing against time was a huge thrill factor for older children. Apart from its joyful and playful time-taking of how far you get and who gets there first, the Play Timer also functions as a practical turn-taking assistant, timing durations of 10 or 30 seconds, as well as 2 or 5 minutes. This is the playful – and to teachers effortless –

way to make children turn-take without conflicts. The Play Timer increases the intensity of play, it increases cooperation and helps children pay attention to each other.



# Outdoor Play Timer

PCM201

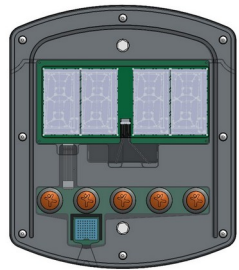

The reflective LCD display has four digits of 100mm height, with excellent outdoor visibility and a wide viewing angle. An LCD display has a low energy consumption, It is powered by 8 replaceable AA batteries with a lifespan of more than 2 years.

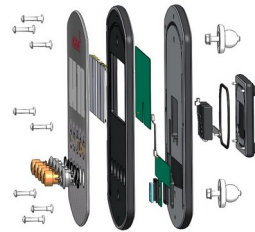

Front panels are made of UV-stabilized Polycarbonate. The UV-stabilization prevents the Transparent panels in being yellow over time and ensures the mechanical performances. The graphic prints are added by a unique multi-layer print process where the inner layer is the image and outer transparent layer functions as protection. The lacquer is water-based, and UV stabilized to prevent fading.



The push buttons and the housing for the push buttons are made from Polyamide (PA6). The buttons contain a magnet which activates a contactless reed switch when the buttons are pushed. This ensures high durability of the system.



The connectors are made of die-cast aluminum specially alloyed for outdoor environments and with a lead content below 100ppm. The connectors are attached to the posts by stainless steel screws and well protected against corrosion by special designed zinc washers. Extremely strong and no change of corrosion.

The loudspeaker is a piezoelectric speaker with a sound level of 90dB, and low power consumption. As power source we use eight standard AA 1,5V replaceable batteries with a capacity of 2.95Ah. The expected lifetime of the batteries is two years, depending on usage. It is recommended to inspect the batteries yearly. The batteries are placed in two sealed battery boxes with a protection class of IP65.



Steel posts are made of Ø101,6 x 2,0mm pre-galvanized steel tube. The posts are powder coated. Tops of posts are sealed with plastic caps (PA6). Footings for surface installation are manufactured from Carbon steel with hot-dip galvanized surface according to ISO1461.

Item no. PCM201-0901	
Installation Information	
Max. fall height	0'0"
Safety surfacing area	43ft²
Total installation time	2.4
Excavation volume	0.04yd³
Concrete volume	0.01yd³
Footing depth (standard)	2'9"
Shipment weight	72lbs
Anchoring options	In-ground ✓ Surface ✓
Warranty Information	
Polycarbonate PC panels	10 Years
Post	10 Years
Spare Parts Availability	10 Years

Elevated activities 0	Accessible elevated activities	Accessible ground level activities	Accessible ground level play types
Present	0	1	1
Required	0	1	1

**ASTM F1487**  
compliant

# Sustainability Data

PCM201



Cradle to Gate A1-A3	Total CO <sub>2</sub> emission	CO <sub>2</sub> e/kg	Recycled materials
	kg CO <sub>2</sub> e	kg CO <sub>2</sub> e/kg	%
<b>PCM201-0901</b>	79.36	3.47	51.13

The overall framework applied for these factors is the Environmental Product Declaration (EPD), which quantifies "environmental information on the life cycle of a product and enable comparisons between products fulfilling the same function" (ISO, 2006). This follows the structure and applies a Life-Cycle Assessment approach to the entire Product stage from raw material through manufacturing (A1-A3))

**Kompan A/S**  
 C.F. Tietgens Boulevard 32C  
 DK-5220 Odense SØ  
 Denmark



## Verification of CO<sub>2</sub> calculation of: Park



Data version no. 2023-10-05

The CO<sub>2</sub> calculation and data are in compliance with the principles of a carbon footprint impact according to the GHG protocol (Greenhouse Gas Protocol), Scope 3, cradle to gate related to all individual components in the product category: "Park" represented by item no.: PAR4070-0001.

(Scope 3 emissions include emission sources in the upstream and downstream value chain).

**Date: 30. October 2023 | Valid until: 30. October 2025**

**Verified by:**

Julie Marie Vejsgaard Larsen, LCA & EPD Consultant

Verification based on report: Validation of CO<sub>2</sub> calculation of 9 categories of Kompan product line, version 1.0, prepared by: Bureau Veritas HSE, Denmark: Julie M. V. Larsen.

**Publication date: 30. October 2023**

**By Bureau Veritas HSE**  
 www.bureauveritas.dk  
 +45 7731 1000



# Outdoor Play Timer

PCM201

\* Max fall height | \*\* Total height | \*\*\* Safety surfacing area

\* Max fall height | \*\* Total height

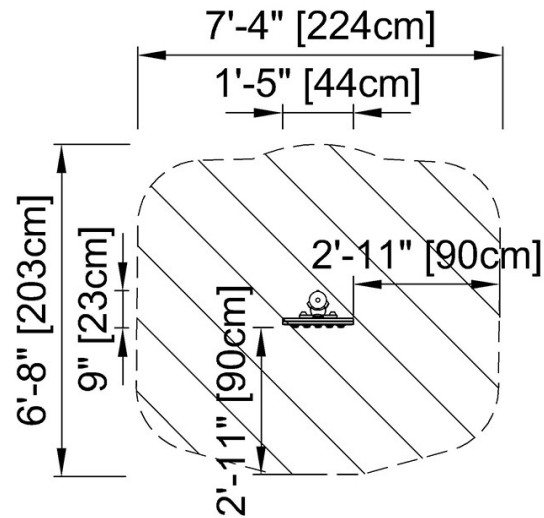

PCM201  
\*\* 4'-2" / 127cm  
\*\*\* 43.1ft<sup>2</sup> / 4m<sup>2</sup>

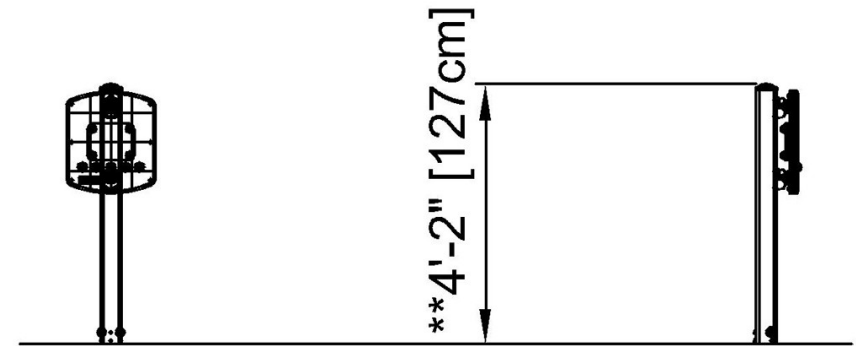

PCM201

[Click to see TOP VIEW](#)

[Click to see SIDE VIEW](#)